



**Contract No. C-GY-T1147-P001**

**for the Provision of Consultancy Services for  
the Gas to Power Feasibility Assessment in  
Guyana**

**Final Report**

**June 2019**



# Table of Contents

---

<b>1</b>	<b>Abbreviations</b>	<b>1</b>
<b>2</b>	<b>Executive Summary</b>	<b>3</b>
2.1	Major Questions to be Answered by the Study	3
2.2	Results of the Study	4
2.2.1	Electricity Supply and Demand Analysis	4
2.2.2	Gas Supply and Demand	13
2.2.3	Viability of Conversion of Existing Facilities to Natural Gas	13
2.2.4	New Plant Site, Size and Technology Considerations	14
2.2.5	Cost-Benefit Analysis of the Alternatives	15
2.2.6	Emission Reduction and Climate Benefits	17
2.2.7	Conceptual Design	18
2.2.8	Cost Estimate	18
2.2.9	Financing Options Analysis	21
2.2.10	Financial and Economic Analysis	21
2.2.11	Grid Impact Analysis	24
2.2.12	Implementation Plan	25
2.2.13	Conclusions and Recommendations	25
2.2.14	Recommendation	26
<b>3</b>	<b>Introduction</b>	<b>27</b>
<b>4</b>	<b>Electricity Supply and Demand Analysis</b>	<b>29</b>
4.1	Current Supply and Demand	29
4.1.1	Existing Generators	29
4.1.2	Electricity Demand Analysis – 2017	30
4.2	Demand Growth and Generation Capacity Forecasts	32
4.2.1	Approach to Estimating Reserve Margin	33
4.2.2	Demand and Supply Analysis for Wartsila RICE Technology Option	33
4.2.3	Demand and Supply Analysis for LM2500 Combine Cycle Technology Option	36
4.3	Analysis of Forecasted Generation from Different Sources	41
4.3.1	Electricity Demand Analysis – 2023	42
4.3.2	Electricity Demand Analysis – 2035	47
<b>5</b>	<b>Gas Supply and Demand Analysis</b>	<b>53</b>
5.1	Natural Gas Supply	53
5.1.1	Natural Gas Demand	54
5.1.2	Natural Gas Properties	55
<b>6</b>	<b>Viability of Conversion of Guyana’s Existing Oil-Fired Power Plants to Natural Gas or Dual Fuel Operation</b>	<b>57</b>

<b>7</b>	<b>New Power Plant Site, Size and Technology Options Analysis</b>	<b>58</b>
7.1	New Power Plant Site	58
7.2	Plant Size Considerations	58
7.2.1	Possible Maximum Sizes of New Gas Fired Power Plants	60
7.2.2	Required Firm Capacity Additions	61
7.2.3	Plant Configuration Considerations	63
7.3	Technology Options	63
7.3.1	GTs of ~15MW range in Simple Cycle	65
7.3.2	GTs of ~15MW range in Combined Cycle	66
7.3.3	GTs of ~25MW range in Simple Cycle	68
7.3.4	GTs of ~25MW range in Combined Cycle	69
7.3.5	Medium-speed Reciprocating Internal Combustion Engines	70
7.3.6	Summary of technology options considered	72
<b>8</b>	<b>Gas Availability, Properties, and Delivery Arrangements,</b>	<b>76</b>
<b>9</b>	<b>Cost/Benefit Analysis of the Alternatives</b>	<b>77</b>
9.1	Methodology	77
9.1.1	Capacity and Generation Forecasts	77
9.1.2	Assumptions	79
9.2	Summary of Results	80
9.2.1	LCOE summary for 60 MW PV Solar Penetration Scenario	82
9.3	Sensitivity Analysis	83
9.4	Recommendations	84
9.5	Expansion Optimization	85
<b>10</b>	<b>Emission Reductions and Climate Benefits</b>	<b>88</b>
<b>11</b>	<b>Conceptual Design for Two Best Technology Options</b>	<b>94</b>
11.1	General Considerations and Assumptions	94
11.1.1	Gas Delivery	95
11.1.2	Power Plant Generic Location	96
11.1.3	Provisions for Equipment, Material, and Backup Fuel Delivery	96
11.1.4	Water Supply	97
11.2	Wartsila RICE Options	97
11.2.1	30 MMscfd Scenario	97
11.2.2	50 MMscfd Scenario	98
11.3	LM2500 Combined Cycle Options	99
11.3.1	30 MMscfd Scenario	99
11.3.2	50 MMscfd Scenario	100
<b>12</b>	<b>Cost Estimates</b>	<b>102</b>
<b>13</b>	<b>Financing Options Analysis</b>	<b>104</b>

13.1	Comparison between IPPs versus direct procurement	104
13.2	Potential Sources of Equity and Debt Finance	108
13.2.1	Sources of Equity Financing	108
13.2.2	Sources of Debt Financing	108
<b>14</b>	<b>Financial and Economic Analysis</b>	<b>110</b>
14.1	Model structure and methodology	110
14.2	Base case scenario and results	111
14.3	Tariff Analysis	114
14.3.1	Wartsila RICE option, 30 MMSCFD gas supply	116
14.3.2	Wartsila RICE option, 50 MMSCFD gas supply	117
14.3.3	LM 2500 CC, 30 MMSCFD gas supply	119
14.3.4	LM 2500 CC, 50 MMSCFD gas supply	120
14.4	Life Cycle Cost and Levelized Cost of Electricity	122
14.4.1	Life Cycle Cost Analysis	122
14.4.2	Levelized Cost of Electricity	123
14.5	Sensitivity Analysis	124
14.5.1	CAPEX	125
14.5.2	Leverage	125
14.5.3	Interest Rate	126
14.5.4	Natural Gas Price	127
14.6	Conclusion	128
<b>15</b>	<b>Dispatch Model</b>	<b>129</b>
<b>16</b>	<b>Grid Impact Analysis</b>	<b>132</b>
16.1	Grid Impact Conclusions and Recommendations	144
<b>17</b>	<b>Terms of Gas Supply Agreement</b>	<b>146</b>
<b>18</b>	<b>Regulatory Framework Review</b>	<b>148</b>
18.1	Review of existing regulatory framework	148
18.1.1	Petroleum (Exploration and Production) Act 1986	148
18.1.2	Electricity Sector Reform Act	149
18.1.3	Guyana Energy Agency (GEA) Act 1997	149
18.1.4	Public Utilities Commission (PUC) Act	149
18.1.5	Environmental Protection Act 1996	149
18.2	Recommendations on regulatory framework	150
18.2.1	Electricity regulations	150
18.2.2	Environmental regulations	150
18.2.3	Fuel regulations	151
<b>19</b>	<b>Project Implementation Roadmap</b>	<b>153</b>
<b>20</b>	<b>Conclusions</b>	<b>157</b>

<b>21</b>	<b>Recommendations</b>	<b>158</b>
-----------	------------------------	------------

## Appendices

<b>Appendix A : Preliminary Site Plans</b>	<b>159</b>
A.1 RICE units (e.g. Wartsila)	159
A.2 Combined Cycle Gas Turbine (e.g. GE LM2500)	160
<b>Appendix B : Electrical Single-Line Diagrams</b>	<b>161</b>
B.1 Case 1 - RICE units (30 MMscfd)	161
B.2 Case 2 - RICE Units (50 MMscfd)	162
B.3 Case 3 - Combined Cycle Gas Turbine units (30 MMscfd)	163
B.4 Case 4 - Combined Cycle Gas Turbine Units (50 MMscfd)	164
<b>Appendix C GSA Term Sheet</b>	<b>165</b>
<b>Appendix D : GSA risk mitigation</b>	<b>172</b>
<b>Appendix E : Generation Outputs</b>	<b>182</b>
<b>Appendix F : Cost Estimates</b>	<b>183</b>
F.1 RICE 30 MMscfd	183
F.2 RICE 50 MMscfd	184
F.3 LM2500 Combined Cycle 30 MMscfd	185
F.4 LM2500 Combined Cycle 50 MMscfd	186

## List of Tables

Table 2.1: Generation Expansion 30 MMscfd Scenario (Wartsila RICE Option)	5
Table 2.2: Generation Expansion 50 MMscfd Scenario (Wartsila RICE Option)	6
Table 2.3: Generation Expansion 30 MMscfd Scenario (LM2500 CC Option)	8
Table 2.4: Generation Expansion 50 MMscfd Scenario (LM2500 CC Option)	9
Table 2.5: Capacity and Cost Characteristics of Generating Resources Considered in this Study	15
Table 2.6: Other Technical Characteristics of Generating Resources Considered in this Study	15
Table 2.7: Key Characteristics and Assumptions	18
Table 2.8: Summary of Major Capital Costs	20
Table 2.9: Tariff Analysis	22
Table 2.10: Life Cycle Cost Analysis Results	23
Table 2.11: Summary of Grid CAPEX Investment Scenarios (all values in US\$)	24
Table 4.1: Existing Generators - DBIS	29
Table 4.2: Generation Expansion 30 MMscfd Scenario (Wartsila RICE Option)	34

Table 4.3: Generation Expansion 50 MMscfd Scenario (Wartsila RICE Option)	35
Table 4.4: Generation Expansion 30 MMscfd Scenario (LM2500 CC Option)	38
Table 4.5: Generation Expansion 50 MMscfd Scenario (LM2500 CC Option)	40
Table 4.6: Power Plant Capacities (Based on the Expansion Study 30 MMscfd Gas Scenario), MW	41
Table 4.7: Power Plant Capacities (Based on the Expansion Study 50 MMscfd Gas Scenario)	42
Table 5.1: Natural Gas Composition	55
Table 5.2: Natural Gas Heating Values	55
Table 7.1: Reserve Capacity Margins for Island Utilities	60
Table 7.2: Maximum Gas Plant Capacities for Different Technology Options and Gas Flows	60
Table 7.3: Estimated DBIS System New Capacity Requirements	61
Table 7.4: Capacity and Cost Characteristics of Generating Resources Considered in this Study	72
Table 7.5: Other Technical Characteristics of Generating Resources Considered in this Study	72
Table 7.6: Technical Advantage/Disadvantage Summary	74
Table 9.1: Capacity and Cost Characteristics of Generating Resources Considered in this Study	77
Table 9.2: Generation and Capacity Forecasts	78
Table 9.3: Generation Options Expansion	79
Table 9.4: Assumptions	80
Table 9.5: Cost Comparison of Power Supply Options	80
Table 9.6: Pros and Cons of LM2500 CC versus Wartsila Reciprocating Engines	84
Table 9.7: Expansion Scenarios (all units in MW)	85
Table 10.1: IFC EHS NOx Emission Limits, mg/Nm <sup>3</sup>	90
Table 10.2: Total Emissions and Emission Reduction 2023-2035 (30 MMSCFD)	90
Table 10.3: Total Emissions and Emission Reduction 2023 -2035 (50 MMSCFD)	91
Table 10.4: Carbon Credits Estimate for CO <sub>2</sub> e Reduction (30 MMSFD case)	92
Table 10.5: Carbon credits estimate for CO <sub>2</sub> e reduction (50 MMSCFD case)	92
Table 10.6: Cost of SO <sub>x</sub> and NO <sub>x</sub> reduction	93
Table 11.1: Summary of Key Characteristics of Generating Alternatives	95
Table 12.1: Summary of Major Costs (all costs in US\$)	103
Table 13.1: IPP versus Procurement through EPC	105
Table 14.1: 30 MMscfd Scenario Expansion Phases	112
Table 14.2: 50 MMscfd Scenario Expansion Phases	112

Table 14.3: Tariff Analysis	113
Table 14.4: Base Case Assumptions	114
Table 14.5: Life Cycle Cost Analysis Results	123
Table 14.6: Levelized Cost of Energy	124
Table 16.1: Power Flow Models Developed	134
Table 16.2: Summary of major Grid Interconnection Costs to Enable Gas Plant Evacuation	141
Table 16.3: Summary of Grid CAPEX Investment Scenarios (all values in US\$)	145
Table 17.1: PPA and ECA Gas Supply Risk Allocations	146

## List of Figures

Figure 2.1: Generation Structure 2023 (Expansion Study PV Solar)	10
Figure 2.2: Generation Structure 2023 - 30 MW Solar	11
Figure 2.3: Generation Structure 2023 - 60 MW Solar	11
Figure 2.4: Generation Structure 2035 (Expansion Study PV Solar)	12
Figure 2.5: Generation Structure 2035 – (30 MW Solar Expansion)	12
Figure 2.6: Generation Structure 2035 – (60 MW Solar Expansion)	12
Figure 2.7: Cost Ranking of Options (LCOE - US\$/MWh)	16
Figure 2.8: Cost Ranking of Options - 60 MW Solar (LCOE - US\$/MWh)	17
Figure 4.1: Load Duration Curve - 2017	31
Figure 4.2: Annual Average Daily Load Curves	31
Figure 4.3: Daily Load Curves by Day of the Week for the 2017 Peak Load Week	32
Figure 4.4: Daily Load Curves by Day of the Week for an Average Week	32
Figure 4.5: Capacity Forecasts. 2018 – 2035 (30 MMscfd Scenario, Wartsila RICE Option)	35
Figure 4.6: Capacity Forecasts. 2017 – 2035 (50 MMscfd Scenario, Wartsila RICE Option)	36
Figure 4.7: Capacity Forecasts. 2018 – 2035 (30 MMscfd Scenario, LM2500 CC Option)	39
Figure 4.8: Capacity Forecasts. 2018 – 2035 (50 MMscfd Scenario, LM2500 CC Option)	41
Figure 4.9: Load Duration Curve, 6MW Solar – 2023 (30 MMscfd)	43
Figure 4.10: Load Duration Curve, 30 MW Solar – 2023 (30 MMscfd)	43
Figure 4.11: Load Duration Curve, 60 MW Solar - 2023 (30 MMscfd)	43
Figure 4.12: Generation Structure, 6 MW Solar – 2023 (30 MMscfd)	44
Figure 4.13: Generation Structure, 30 MW Solar - 2023 (30 MMscfd)	44
Figure 4.14: Generation Structure, 60 MW Solar – 2023 (30 MMscfd)	44
Figure 4.15: Load Duration Curve, 24 MW Solar – 2023 (50 MMscfd)	45
Figure 4.16: Load Duration Curve, 30 MW Solar - 2023 (50 MMscfd)	45
<b>Figure 4.17: Load Duration Curve, 60 MW Solar – 2023, (50 MMscfd)</b>	<b>46</b>



Figure 4.18: Generation Structure, 24 MW Solar – 2023 (50 MMscfd)	46
Figure 4.19: Generation Structure, 30 MW Solar - 2023 (50 MMscfd)	46
Figure 4.20: Generation Structure, 60 MW Solar – 2023 (50 MMscfd)	47
Figure 4.21: Load Duration Curve, Solar 6 MW – 2035 (30 MMscfd)	47
Figure 4.22: Load Duration Curve, Solar 30 MW - 2035 (30 MMscfd)	48
Figure 4.23: Load Duration Curve, Solar 60 MW – 2035 (30 MMscfd)	48
Figure 4.24: Generation Structure, 6 MW Solar – 2035 (30 MMscfd)	49
Figure 4.25: Generation Structure, 30 MW Solar - 2035 (30 MMscfd)	49
Figure 4.26: Generation Structure, 60 MW Solar – 2035 (30 MMscfd)	49
Figure 4.27: Load Duration Curve, Solar 24 MW – 2035 (50 MMscfd)	50
Figure 4.28: Load Duration Curve, Solar 30 MW - 2035 (50 MMscfd)	51
Figure 4.29: Load Duration Curve, Solar 60 MW – 2035 (50 MMscfd)	51
Figure 4.30: Generation Structure, 24 MW Solar – 2035 (50 MMscfd)	51
Figure 4.31: Generation Structure, 30 MW Solar - 2035 (50 MMscfd)	52
Figure 4.32: Generation Structure, 60 MW Solar – 2035 (50 MMscfd)	52
Figure 5.1: Stabroek Oil Field Block Development	53
Figure 7.1: Target Reserve Margins for U.S. Regions	59
Figure 7.2: Heat Balance for Option 1 (typical)	65
Figure 7.3: Heat balance for Option 2 (typical)	67
Figure 7.4: Heat balance for Option 3 (typical)	69
Figure 7.5: Heat balance for Option 4 (typical)	70
Figure 7.6: Heat balance for Option 5 (typical)	71
Figure 7.7: Aging effect comparison	73
Figure 9.1: Cost Ranking of Power Options (Unit Cost of Electricity, LCOE-US\$/MWh)	81
Figure 9.2: Cost Ranking of Power Options (Unit Cost of Electricity, LCOE - US\$/MWh). 60 MW PV Solar Penetration	82
Figure 9.3: Sensitivity to CAPEX	83
<b>Figure 9.4: Sensitivity to Fuel Oil Prices</b>	83
Figure 9.5: Sensitivity to Natural Gas Price	84
Figure 9.6: Expansion Optimization Results 30 MMscfd Gas Supply	86
Figure 9.7: Expansion Optimization 50 MMscfd	87
Figure 11.1: Heat and Material Balance for Wartsila RICE at 30 MMscfd	98
Figure 11.2: Heat and Material Balance for Wartsila RICE at 50 MMscfd	98
Figure 11.3: Heat and Material Balance for LM2500 CC at 30 MMscfd	100
Figure 11.4: Heat and material Balance for LM2500 CC at 50 MMscfd	101
Figure 13.1: Typical IPP Structure	107



Figure 13.2: Typical EPC structure	107
Figure 14.1: Model Structure	110
Figure 14.2: Tariff Calculation	115
<b>Figure 14.3: Tariff Breakdown for Wartsila 30 MMSCFD Gas Supply Scenario – IPP based</b>	116
Figure 14.4: Tariff Breakdown Wartsila RICE, 30 MMSCFD - EPC based (Commercial Loan)	116
Figure 14.5: Tariff Breakdown Wartsila RICE, 30 MMSCFD - EPC based (DFI Loan)	117
Figure 14.6: Tariff Breakdown Wartsila RICE, 50 MMSCFD - IPP	117
Figure 14.7: Tariff Breakdown Wartsila RICE, 50 MMSCFD – EPC (Commercial Loan)	118
Figure 14.8: Tariff Breakdown Wartsila RICE, 50 MMSCFD – EPC (DFI Loan)	118
Figure 14.9: Tariff breakdown for LM 2500 CC, 30 MMSCFD gas supply - IPP	119
Figure 14.10: Tariff Breakdown LM2500 CC, 30 MMSCFD – EPC (Commercial Loan)	120
Figure 14.11: Tariff Breakdown LM2500 CC, 30 MMSCFD – EPC (DFI Loan)	120
Figure 14.12: Tariff breakdown LM 2500 CC, 50 MMSCFD gas supply - IPP	121
Figure 14.13: Tariff breakdown LM 2500 CC, 50 MMSCFD gas supply- EPC (Commercial Loan)	121
Figure 14.14: Tariff breakdown LM 2500 CC, 50 MMSCFD gas supply- EPC (DFI Loan)	122
Figure 14.15: Tariff/IRR sensitivity to CAPEX	125
Figure 14.16: Tariff/IRR sensitivity to Leverage	126
Figure 14.17: Tariff/IRR sensitivity to interest rates	127
Figure 14.18: Tariff Sensitivity to Natural Gas Prices	128
Figure 16.1: Internet PV Solar Irradiation Data	134
Figure 16.2: 2035 PSS/E Model One-Line Diagram Example	137
Figure 16.3: 69 kV Only Interconnection Detail Example	138
Figure 16.4: 230 kV Only Interconnection Detail Example	139
Figure 16.5: 69 kV and 230 kV Interconnection Detail Example	140
Figure 19.1: Project Implementation Plan. IPP Option	155
Figure 19.2: Project Implementation Plan. EPC Option	156

# 1 Abbreviations

---

CFCs	Chlorofluorocarbons
CO <sub>2</sub>	carbon dioxide
CNG	compressed Natural Gas
CBA	cost-benefit analysis
CAPEX	capital expenditures
EEPGL	Esso Exploration and Production Guyana Limited
ESRA	Electricity Sector Reform Act
EU	European Union
FPSO	floating production, storage, and offloading
G\$	Guyana dollar
GDP	gross domestic product
GHG	greenhouse gases
GoG	Government of Guyana
GPL	Guyana Power & Light
HFO	heavy fuel oil
IPP	independent power producer
IADB or IDB	Inter-American Development Bank
IRR	internal rate of return
kWh	kilowatt-hour
LCOE	levelized cost of energy
LFO	light fuel oil
LNG	liquefied Natural Gas
LPG	liquid petroleum gas
MPI	Ministry of Public Infrastructure
MMBtu	million British thermal units
MMscf	million standard cubic feet
MMscfd	million standard cubic feet per day
MW	megawatt
MWh	megawatt-hour
NGL	Natural Gas liquids
NO <sub>x</sub>	nitrogen oxide

NPV	net present value
NREL	national renewable energy laboratory
O&M	operation and maintenance
OPEX	operating expenditure
PPP	public-private partnership
RICE	reciprocating internal combustion engine
SAM	system advisor model
SOx	sulfur oxide
Tcf	trillion cubic feet
UNFCCC	United Nations Framework Convention on Climate Change
US	United States
US\$	United States dollar
WHO	World Health Organization

## 2 Executive Summary

---

IADB is assisting the Government of Guyana to develop a strategy for the optimal use of indigenous gas sources for power production. As part of this program, IADB selected K&M Advisors via a competitive selection process to conduct the Gas to Power Feasibility Assessment in Guyana. This Final Report is prepared as part of this assignment.

### 2.1 Major Questions to be Answered by the Study

The major goals of the study are the assessment of use of indigenous natural gas for power generation, selection of two best options for the new power plant that should be recommended for further in-depth analysis, and analyze those two options from a technical, commercial, and financial perspective. To achieve these goals, the Final Report addresses the following major questions:

- What is Guyana's projected demand for power and requirements for power generating capacity?
- How much Natural Gas is available for power generation in Guyana and how much power can be generated using this Natural Gas?
- Whether conversion of existing HFO-fired power plants to Natural Gas is a viable option?
- What are viable size and technology options that can be utilized for a new gas fired power plant?
- What is the expected dispatch of a new gas fired power plant considering projected demand, addition of renewables, and other existing and projected power generating capacities in the DBIS system?
- What are the estimated emission reductions and climate benefits of a new power plant?
- What are the two best generation technology options taking into consideration technical, financial, and commercial aspects?
- What is the conceptual design for the two best generation technology options selected for two gas supply scenarios?
- What improvements are required to be implemented to the grid to evacuate power generation by the Project for two best technology options?
- What is the estimated capital cost for two best options?
- What is the expected cost of electricity generated by the Project?
- What are the Project financing options?
- Are there any additional regulations that should be in place for Project development and implementation?
- What is the sequence and the timeline of the Project development activities?

To respond to these questions, the Final Report covers the following:

- Supply and Demand Analysis for:

- Electricity; Including dispatch analysis, generation and capacity forecasts, and scenario modeling for different gas and renewable capacities
- Gas; Including gas delivery options and impacts of different gas capacities on System operations.
- Technical and Cost-Benefit review for Gas-to-Power plants option, which includes
  - Analysis of Viability of Conversion to Existing Facilities to Dual Fuel Operation
  - New Power Plant Size, Site, and Technology Options Analysis
  - Cost Benefits Analysis of the considered Options
  - Emission Reductions and Climate Benefits
- Conceptual Design and Cost Estimate
- Financing Options Analysis
- Financial Modeling and Analysis

The report also includes supplementary sections presenting the dispatch model that could be used by GPL for merit order dispatch of their thermal power plants, major terms and conditions of gas supply agreement, and review of regulatory requirements associated with operation of a gas fired power plant.

## **2.2 Results of the Study**

The analysis conducted in this Study was based on different scenarios of gas supply, high and low penetration of PV Solar, and different technological options for the gas-to-power plants. K&M conducted the analysis on electricity demand and supply, gas demand and supply, forecasted dispatch, cost-benefit analysis for each option and scenario, and emissions reductions. K&M then performed conceptual design, cost estimate, and financing option and financial performance analysis for the two best options identified as a result of the cost-benefit analysis. The summarized results of the report are presented below:

### **2.2.1 Electricity Supply and Demand Analysis**

#### **Electricity Demand and Supply – 2017**

Following the Expansion Study, the Electricity Demand and Supply analysis in this section and the rest of the report focused on the Demerara Berbice Interconnection System – DBIS with Linden. DBIS is the main electrical grid in Guyana. According to the Expansion Study, in 2017 sales of electricity in DBIS amounted to 555.3 GWh (approximately 88% of the total power generation in the country). Linden is the second largest city in Guyana and presently the Linden Electrical System is not connected to DBIS and is planned to be interconnected with DBIS by 2024 (based on the Expansion Study). The Expansion Study estimates the electricity sales in Linden at 73.3 GWh (approximately 12% of the total generation in the country)

As of 2017, there are a total of nine generating facilities in DBIS with a combined generating capacity of 136.9 MW and most of these generating facilities operate on HFO. The electricity demand for Guyana is relatively flat with 90% of load in 2017 ranging between 75 MW and 114 MW. Based on 2017 historic load data, the required firm generating capacity for DBIS was 131 MW (114 MW peak capacity plus 17 MW reserve capacity). The current installed capacity of 136.9 MW

seems adequate to cover existing demand, but, may not be sufficient due to the low availability and planned retirements of existing units, transmission system constrains, and unserved demand that would connect to the grid if it has higher reliability of power supply. By 2027, the peak demand increases to 291 MW due to the anticipated economic growth resulting from the recent offshore oil discovery<sup>1</sup>.

### Demand Growth and Capacity Additions

K&M reviewed the demand growth<sup>2</sup> and capacity additions presented in the Expansion Study and analyzed associated capacity requirements to confirm whether this demand including the required reserve margin can be satisfied by planned capacity additions. K&M also estimated the expected annual electricity production by different sources. Table 2.1 and Table 2.2 below show the generation expansion based on the 30 and 50 MMscfd gas scenarios.

The demand growth data and generation capacity additions used in the analysis are based on the “Delayed Base Case” Scenario in the Expansion Study. The Delayed Base Case Scenario assumes that the electricity demand growth in Guyana would lag behind the expected growth in GDP resulting from the recent oil discoveries off Guyana’s coast and the associated investments. The authors of the Expansion Study based this approach on their experience with demand growth in other countries with power sectors similar to power sector in Guyana. K&M considers that this approach is reasonable.

For the 30 MMscfd scenario the Expansion Study considered that this quantity of natural gas can support operation of ten 17 MW Wartsila dual-fuel reciprocating engines. Based on K&M’s heat and material balance calculations, 30 MMscfd of natural gas can sufficiently operate 9 Wartsila engines and as such the maximum capacity of new gas-fired power plant is limited to 153 MW versus 170 MW considered in the Expansion Study. As demonstrated in Table 2.1, this leads to the system experiencing firm capacity deficit of 15 MW by 2026 resulting in the system reserve margin of only 23 MW, which is below 2 times the size of the largest unit. Based on that, it seems that the hydro power plant will have to be completed in 2026 instead of 2027 as envisioned in the Expansion Study. According to the Expansion Study, it takes 4 years to complete the Amalia hydropower plant, so there appears to be enough time to construct this plant from a technical perspective. However, there may be additional environmental, political, and social reasons that could cause delays in hydropower plant development. In that case additional HFO-based power will have to be added by 2026 to address the deficit of firm capacity.

**Table 2.1: Generation Expansion 30 MMscfd Scenario (Wartsila RICE Option)**

Type	Unit	2018	2019	2020	2021	2023	2024	2025	2026	2027	2035
HFO	MW	136.9	145.6	145.6	179.6	126.6	126.6	126.6	126.6	126.6	115.6
Solar	MW		6.0	6.0	6.0	6.0	6.0	6.0	6.0	6.0	6.0
Gas	MW		-	-	-	119.0	153.0	153.0	153.0	153.0	153.0
Wind	MW		10.3	10.3	10.3	10.3	10.3	10.3	10.3	10.3	10.3
Biomass	MW		-	-	13.8	13.8	13.8	13.8	13.8	13.8	13.8

<sup>1</sup> Based on the delayed base case forecast provided in the Update to the Expansion Study, 2018.

<sup>2</sup> Ibid.

Type	Unit	2018	2019	2020	2021	2023	2024	2025	2026	2027	2035
Hydro	MW		-	-	-	-	-	-	-	165.0	165.0
Total Capacity	MW	137	162	162	210	276	310	310	310	475	464
<b>Total Firm Capacity</b>	<b>MW</b>	<b>137</b>	<b>146</b>	<b>146</b>	<b>180</b>	<b>246</b>	<b>280</b>	<b>280</b>	<b>280</b>	<b>445</b>	<b>434</b>
Maximum Demand	MW	117	121	125	129	154	194	224	256	291	330
System Reserve	MW	18	21	21	34	34	34	34	38	44	50
<b>Total Firm Capacity Required</b>	<b>MW</b>	<b>135</b>	<b>142</b>	<b>146</b>	<b>163</b>	<b>188</b>	<b>228</b>	<b>258</b>	<b>294</b>	<b>334</b>	<b>434</b>
<b>Surplus (Deficit)</b>	<b>MW</b>	<b>2</b>	<b>4</b>	<b>(0)</b>	<b>17</b>	<b>58</b>	<b>52</b>	<b>22</b>	<b>(15)</b>	<b>110</b>	<b>54</b>

**Table 2.2: Generation Expansion 50 MMscfd Scenario (Wartsila RICE Option)**

Type		2018	2019	2020	2021	2023	2024	2025	2026	2027	2028	2035
HFO	MW	136.9	145.6	145.6	179.6	126.6	126.6	126.6	126.6	126.6	126.6	115.6
Solar	MW		6.0	24.0	24.0	24.0	24.0	24.0	24.0	24.0	24.0	24.0
Gas	MW		-	-	-	102.0	136.0	170.0	204.0	238.0	255.0	255.0
Wind	MW		10.3	10.3	40.3	40.3	40.3	40.3	40.3	40.3	40.3	40.3
Biomass	MW		-	-	23.8	23.8	23.8	23.8	23.8	23.8	23.8	23.8
Hydro	MW		-	-	-	-	-	-	-	-	-	-
Total Capacity	MW	137	162	180	268	317	351	385	419	453	470	459
<b>Total Firm Capacity</b>	<b>MW</b>	<b>137</b>	<b>146</b>	<b>146</b>	<b>180</b>	<b>229</b>	<b>263</b>	<b>297</b>	<b>331</b>	<b>365</b>	<b>382</b>	<b>371</b>
Maximum Demand	MW	117	121	125	129	154	194	224	256	291	317	330
Required System Reserve	MW	18	18	19	19	34	34	34	38	44	48	50
<b>Total Firm Capacity Required</b>	<b>MW</b>	<b>135</b>	<b>139</b>	<b>144</b>	<b>148</b>	<b>188</b>	<b>228</b>	<b>258</b>	<b>294</b>	<b>334</b>	<b>365</b>	<b>380</b>
<b>Surplus (Deficit)</b>	<b>MW</b>	<b>2</b>	<b>6</b>	<b>1</b>	<b>31</b>	<b>41</b>	<b>35</b>	<b>39</b>	<b>36</b>	<b>30</b>	<b>17</b>	<b>(9)</b>

In addition to the generation expansion, Table 2.1 and Table 2.2 also show required capacity (including reserves) and the difference (surplus or deficit) between the available and required firm capacities. This difference is an important metric that shows whether the system has enough firm capacity to meet the expected peak demand and can cover peak demand in case of generating unit outages. It is also important to distinguish between firm capacity, which includes HFO, Gas, and Hydro with total capacity that includes intermittent sources like Biomass, Solar and Wind.

The reserve margin in the above table is calculated as 15% of the peak demand (the approach used in the Expansion Study) or 2 times the capacity of the largest unit (the deterministic method used by GPL and several other utilities in countries around the world), whichever is higher. The method of setting the required reserve margin at 2 times the capacity of the largest unit is based



on a requirement that the system can cover the peak load in a situation when one of the largest units experiences a forced outage and another largest unit has maintenance outage. It should be noted that another commonly used method for calculating reserve margin target is a probabilistic method based on the Loss of Load Expectation (LOLE) analysis. This method determines a more precise value for the required reserve margin and may further optimize reserve margin investment requirements. Conducting such analysis is beyond the scope of this study. GPL may consider engaging a power system reliability expert to conduct such LOLE analysis to further refine the reserve margin requirements.

In both the expansion scenarios, there is sufficient firm generation capacity till 2035 to cover the peak load. For the 50 MMscfd scenario, the firm capacity in 2035 is below the peak load plus 15% reserve margin by 9 MW; however, at 41 MW the reserve margin is still above 34 MW (2 times the capacity of the largest unit considered in the Expansion Study) and, is considered adequate. However, GPL will have to add firm capacity in 2035 to cover increasing peak loads beyond 2035.

It should be noted that the reserve margin in the above tables is calculated based on the expansion using 17 MW dual fuel reciprocating engines supplied by Wartsila. As presented in the subsequent sections of the study, one of the technology options considered for the new gas fired plant is a combined cycle power plant based on LM2500 gas turbines. For this option a loss of a single gas turbine unit results in capacity loss of approximately 30 MW, which means that the required reserve margin for this case is 60 MW.

In that case, the expansion scenarios will be as presented in Table 2.3 and Table 2.4. As can be seen, the required capacity for the entire period between 2023 (start of commercial operation of first gas fired units at the new plant) and 2035 is adequate. There is a deficit of 9 MW for year 2026 for the 30 MMscfd scenario, which means that the reserve margin during this year will be 51 MW versus required 60 MW. This issue could be addressed by advancing construction of the hydro power plant.

**Table 2.3: Generation Expansion 30 MMsctd Scenario (LM2500 CC Option)**

Type	Unit	2018	2019	2020	2021	2023	2024	2025	2026	2027	2028	2029	2030	2031	2032	2033	2034	2035
HFO	MW	136,9	145,6	145,6	179,6	127	127	127	127	127	127	127	127	127	127	127	116	116
Solar	MW		6	6	6	6	6	6	6	6	6	6	6	6	6	6	6	6
Gas	MW		-	-	-	120	150	180	180	180	180	180	180	180	180	180	180	180
Wind	MW		10,3	10,3	10,3	10	10	10	10	10	10	10	10	10	10	10	10	10
Biomass	MW		-	-	13,8	14	14	14	14	14	14	14	14	14	14	14	14	14
Hydro	MW		-	-	-	-	-	-	-	165	165	165	165	165	165	165	165	165
Total Capacity	MW	137	162	162	210	277	307	337	337	502	502	502	502	502	502	502	491	491
<b>Total Firm Capacity</b>	<b>MW</b>	<b>137</b>	<b>146</b>	<b>146</b>	<b>180</b>	<b>247</b>	<b>277</b>	<b>307</b>	<b>307</b>	<b>472</b>	<b>472</b>	<b>472</b>	<b>472</b>	<b>472</b>	<b>472</b>	<b>472</b>	<b>461</b>	<b>461</b>
Maximum Demand	MW	117	121	125	129	154	194	224	256	291	317	319	321	323	325	327	329	330
System Reserve	MW	18	21	21	34	60	60	60	60	60	60	60	60	60	60	60	60	60
<b>Total Firm Capacity Required</b>	<b>MW</b>	<b>135</b>	<b>142</b>	<b>146</b>	<b>163</b>	<b>214</b>	<b>254</b>	<b>284</b>	<b>316</b>	<b>351</b>	<b>377</b>	<b>379</b>	<b>381</b>	<b>383</b>	<b>385</b>	<b>387</b>	<b>389</b>	<b>390</b>
<b>Surplus (Deficit)</b>	<b>MW</b>	<b>2</b>	<b>4</b>	<b>(0)</b>	<b>17</b>	<b>33</b>	<b>23</b>	<b>23</b>	<b>(9)</b>	<b>121</b>	<b>94</b>	<b>92</b>	<b>91</b>	<b>89</b>	<b>87</b>	<b>85</b>	<b>72</b>	<b>70</b>

**Table 2.4: Generation Expansion 50 MMsctd Scenario (LM2500 CC Option)**

Type	Unit	2018	2019	2020	2021	2,023	2,024	2,025	2,026	2,027	2,028	2,029	2,030	2,031	2,032	2,033	2,034	2,035
HFO	MW	136.9	145.6	145.6	179.6	127	127	127	127	127	127	127	127	127	127	127	116	116
Solar	MW		6.0	24.0	24.0	24	24	24	24	24	24	24	24	24	24	24	24	24
Gas	MW		-	-	-	120	150	180	210	240	270	300	300	300	300	300	300	300
Wind	MW		10.3	10.3	40.3	40	40	40	40	40	40	40	40	40	40	40	40	40
Biomass	MW		-	-	23.8	24	24	24	24	24	24	24	24	24	24	24	24	24
Hydro	MW		-	-	-	-	-	-	-	-	-	-	-	-	-	-	-	-
Total Capacity	MW	137	162	180	268	335	365	395	425	455	485	515	515	515	515	515	504	504
<b>Total Firm Capacity</b>	<b>MW</b>	<b>137</b>	<b>146</b>	<b>146</b>	<b>180</b>	<b>247</b>	<b>277</b>	<b>307</b>	<b>337</b>	<b>367</b>	<b>397</b>	<b>427</b>	<b>427</b>	<b>427</b>	<b>427</b>	<b>427</b>	<b>416</b>	<b>416</b>
Maximum Demand	MW	117	121	125	129	154	194	224	256	291	317	319	321	323	325	327	329	330
System Reserve	MW	18	18	19	19	60	60	60	60	60	60	60	60	60	60	60	60	60
<b>Total Firm Capacity Required</b>	<b>MW</b>	<b>135</b>	<b>139</b>	<b>144</b>	<b>148</b>	<b>214</b>	<b>254</b>	<b>284</b>	<b>316</b>	<b>351</b>	<b>377</b>	<b>379</b>	<b>381</b>	<b>383</b>	<b>385</b>	<b>387</b>	<b>389</b>	<b>390</b>
Surplus (Deficit)	MW	2	6	1	31	33	23	23	21	16	19	47	46	44	42	40	27	25

K&M selected years 2023 and 2035 to run a dispatch analysis to forecast the dispatch of the new gas plant and assess the split of total generated power between existing HFO power plants, new gas plant, hydropower, biomass, solar, and wind. The year 2023 was selected because the new power plant will start operating in 2023 and 2035 was selected as this is the last year in the Expansion Study forecast. During the kickoff mission, it was mentioned that GPL is considering installing an increased amount of PV Solar in the future. K&M's analysis includes the impact of additional PV Solar capacity on the operation of the new gas plant. In addition to the analysis conducted for solar capacity of 6 MW for 30 MMscfd and 24 MW for 50 MMscfd scenarios as specified in the Expansion Study, K&M also conducted analysis for PV solar capacities of 30 MW, and 60 MW for both gas supply scenarios. The results of the analysis are presented in below on Figure 2.1 through Figure 2.6. The generation structure is estimated for the Wartsila RICE technology option. Estimate of generation structure for the LM2500CC technology option demonstrate similar values.

### Electricity Demand and Supply Analysis – 2023

Based on the expansion scenarios in Table 2.1 through Table 2.4, DBIS will have adequate reserves to meet its peak demand plus required reserve margin for both 30 MMscfd and 50 MMscfd scenarios for both of the best technology options and have a surplus capacity of between 33 and 58 MW.

**Figure 2.1: Generation Structure 2023 (Expansion Study PV Solar)**

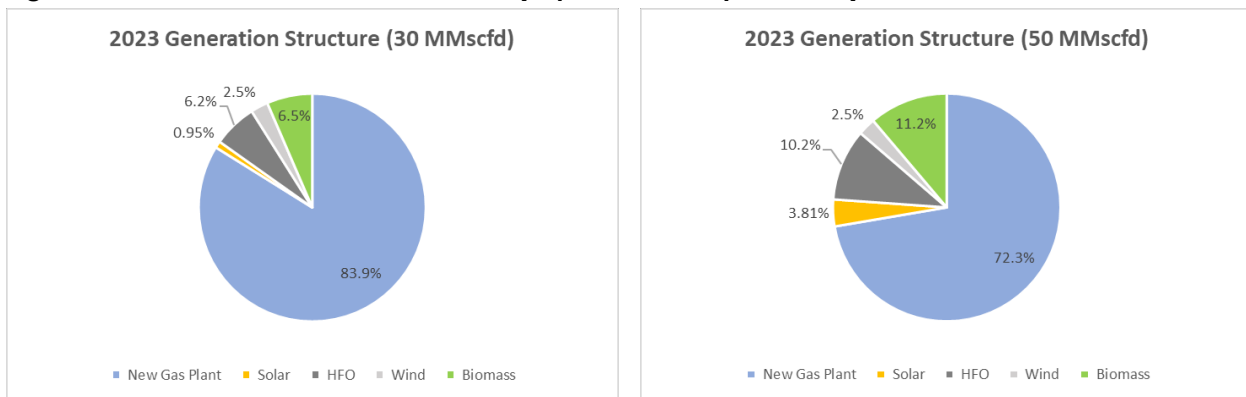

As the above figures show, the new gas plant will provide a significant portion of Guyana's power demand in 2023. Having a significant portion of the total generating capacity located at a single location increases the risk of a system wide blackout in case the new power plant goes offline. To mitigate this risk, the new power plant will be a multi-unit (using a relatively small unit size, see Section 2.2.4.2) facility connected to the grid by a double circuit line. The new gas plant is expected to run as baseload power and provide more than 70% of the total generation for the year for both scenarios, thus dramatically reducing Guyana reliance on imported HFO.

As shown in Figure 2.3 and Figure 2.3, for year 2023 the increased penetration of PV Solar will reduce both the HFO and natural gas-based generation in the system.

**Figure 2.2: Generation Structure 2023 - 30 MW Solar**



**Figure 2.3: Generation Structure 2023 - 60 MW Solar**

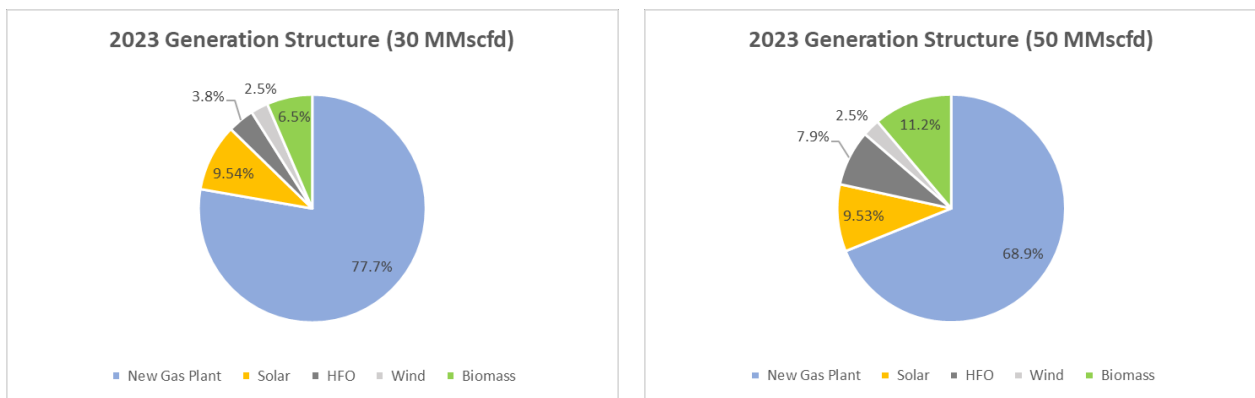

**Electricity Demand and Supply Analysis – 2035**

For the system expansion using dual fuel reciprocating engines considered in the Expansion Study by 2035 Guyana will have a firm capacity requirement of 380 MW and available firm capacity of 451 for 30 MMscfd scenario (71 MW surplus) after addition of new gas and hydropower capacities, but only 371 MW of available firm capacity for the 50 MMscfd scenario (9 MW deficit) after addition of gas-fired capacity. As discussed above, for the 50 MMscfd scenario a deficit of 9 MW means that the system can cover the peak load, but the reserve capacity is below the required 15%. However, the reserve may be considered as sufficient when compared with the size of two largest units. Therefore, K&M considers that the available firm capacity envisioned by the Expansion Study by 2035 will be adequate, but GPL should increase its firm capacity in 2035 to cover future load increases.

For the combined cycle option using LM2500 gas turbines the available firm capacity will be adequate for both 30 MMscfd and 50 MMscfd scenarios.

As shown in Figure 2.5 and Figure 2.6, the increased penetration of PV Solar will further reduce the HFO based generation in the system, but will have minimal impact on generation by the new gas fired power plant.

**Figure 2.4: Generation Structure 2035 (Expansion Study PV Solar)**



**Figure 2.5: Generation Structure 2035 – (30 MW Solar Expansion)**

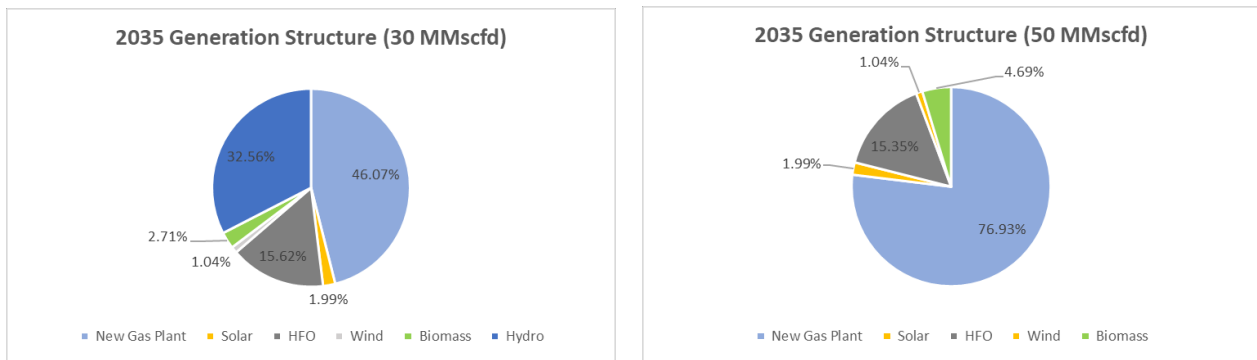

**Figure 2.6: Generation Structure 2035 – (60 MW Solar Expansion)**

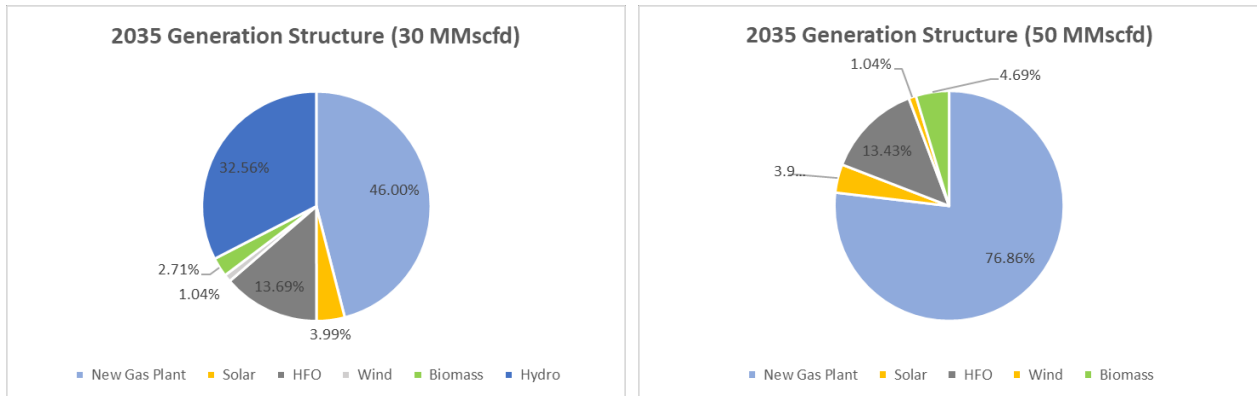

As shown in Figures above, the addition of hydropower for a 30 MMscfd scenario will reduce the share of power generated from the new gas power plant to approximately 46% of the total system generation. This provides Guyana with diversity in firm generating options and reduces the dependence of the electrical system on a single source. Hydropower and Gas can work together to form Guyana's baseload generation providing 83% of the total power generated. The flexibility of gas generation can also provide buffer in case of seasonal variation in hydropower. As can be

seen from the charts, increase in solar generation will not impact generation by gas fired power plant, but will reduce HFO generation.

For the 50 MMscfd scenario, Natural Gas will become the primary source of electricity generation for Guyana with the new gas fired power plant providing 77% of the total power demand. Any disruption in Natural Gas supply could significantly impact the cost of electricity generation in Guyana as it will have to be generated using much more expensive back-up liquid fuel. This risk will be reduced in case of implementation of the Arco Norte transmission interconnection project connecting Guyana, Northern Brazil, Suriname, and French Guyana.

### **2.2.2 Gas Supply and Demand**

ExxonMobil through their subsidiary, Esso Exploration and Production Guyana Limited (EEGPL) is developing the Stabroek oil field block located approximately 190 km offshore Guyana and the gross recoverable resources for the Stabroek Block are now estimated at more than 6 billion recoverable oil-equivalent barrels. The Lisa Phase 1 production project currently underway will tap into approximately 450 million barrels, which is about 11% of the total estimated recoverable reserves.

According to the Expansion Study, the part of Natural Gas reserves that can be allocated for power generation from Lisa-1 production project are estimated at 0.2 Tcf (trillion cubic feet). K&M could not independently verify this information but assumes that this value is based on the information provided by Exxon Mobil. These gas quantities can provide natural gas for approximately 18 years in a 30 MMScfd gas supply scenario and approximately 11 years in a 50 MMScfd scenario, less than the expected life of the new power plant. However, Lisa-1 represents only 11% of the total recoverable oil resources and it would be logical to assume that the total Natural Gas reserves in the Stabroek block are proportionately higher. The most recent developments in the Stabroek block resource assessment and exploration includes updating the figure for recoverable oil resources to be in excess of 6 BBOE and approval of the Liza-2 production project. It should be noted that Liza-2 production project is not expected to provide incremental increase in available quantities of natural gas to the quantities factored in the Liza-1 project.

Assuming that useful life of the new power plants is 30 years, the total quantity of Natural Gas required for power generation over the 30-year period would be 0.37 Tcf for 30 MMscfd and 0.6 Tcf for 50 MMscfd cases (based on the generation capacities discussed in the previous section). It is highly likely that gas reserves in the Stabroek block would be sufficient to support new power plant operation for at least duration of its useful life. Nevertheless, it is extremely important that GPL and GoG obtain firm information and commitment from the prospective supplier of natural gas before proceeding with project implementation.

### **2.2.3 Viability of Conversion of Existing Facilities to Natural Gas**

K&M assessed the viability of converting the existing liquid-fuel based reciprocating engines to dual-fuel reciprocating engines capable of using both HFO and Natural Gas as a fuel source. The older power plants in the DBIS system were not considered in our assessment given that they are nearer to the end of their operating lives and the high cost of conversion. The two newest power plants – Vreed-en-Hoop power station and the Kingston 2 power station could be considered as candidates for potential conversion to dual-fuel operation as they have sufficient remaining operating lives.



However, the estimated cost to conversion would be \$9.2 million and \$12.9 million for the Vreed-en-Hoop power station and the Kingston 2 power station respectively (based on a per kW conversion cost of \$355 provided by Wartsila). Additionally, the cost of gas pipeline between the landing point and the existing power plants is estimated, depending on the distance, at between US\$25 and US\$50 million, so that the total conversion cost would be over \$1000/kW. This cost is comparable to the cost of new dual-fuel units. Also, bringing Natural Gas to the sites of the existing plants appears to be difficult and expensive as the pipelines would need to be routed through heavily developed and populated areas in order to reach the sites. Securing Right-of-Way for the pipelines will be a significant issue. Alternative methods of gas transportation include delivery of natural gas in the form of Compressed Natural Gas (CNG) or Liquefied Natural Gas (LNG) by truck, but supply of CNG or LNG in relatively small volumes significantly increase natural gas cost, and Guyana's highway infrastructure is not optimal for large trucking operations associated with continuous deliveries of natural gas to the existing power plant.

Based on the high cost of conversion and the difficulty of bringing Natural Gas to the existing power plants, conversion of existing power plants to dual fuel (HFO and Natural Gas) operation does not seem to be a viable option and is not recommended.

## **2.2.4 New Plant Site, Size and Technology Considerations**

### **2.2.4.1 Project Site**

The study assumes that the new power plant will be constructed at a generic site located not too far from Georgetown, the major load center. Based on other experiences and considering that the gas will be transported to shore via a pipeline, it is likely that the selected site will be located close to the coast, and since Guyana coast is vulnerable to sea rise effects, shore protection will be required on at least three sides of the plant boundary meaning, the 2 lateral side and the side facing the sea. For the purposes of this study it is assumed that the gas-processing facility will provide their own shore protection system.

Considering the characteristics of the coastal areas of Guyana it is possible that the offshore waters at the site could stay shallow for a long distance. For the conceptual design purposes K&M assumes that a new barge-unloading facility will be installed adjacent to the site so that equipment and materials required for power plant construction and operation would be shipped to Georgetown and off-loaded onto shallow-draft barges for delivery to the site.

### **2.2.4.2 Technology Options and Plant Size Considerations**

The tables below (Table 2.5 and Table 2.6) summarize the generating resources which were considered for this study. The values in these tables are intended to be used in the dispatch and generation planning economic analysis in this report. Each of the generating alternatives listed are not recommended for selection but used as a representative of a class of applicable generation technology. For this reason, the values presented should be considered typical as they will vary depending on the site-specific characteristics and the type of model and plant configuration each vendor offers in response to a solicitation.

**Table 2.5: Capacity and Cost Characteristics of Generating Resources Considered in this Study**

Resources	Summer Capacity (MW)	Installed Cost (\$/kW)	LHV Net Heat Rate (BTU/kWh)	Max Daily Fuel Gas Consumption (MMSCFD)
SGT400 SC	10.8	1,503	10,671	2.75
SGT 400 CC	15.5	1,816	7,382	2.74
LM2500 SC	21.2	1,238	9,785	4.97
LM2500 CC	30.0	1,517	6,915	4.94
Wartsila	17	950	7,689	3.13

**Note**

The information in Table 2.4 is based on plant performance models created using GT PRO/PEACE software from Thermoflow. Heat balances were generated using GT PRO and cost estimates were generated using PEACE.

**Table 2.6: Other Technical Characteristics of Generating Resources Considered in this Study**

Resources	30 MMSCFS Fuel Gas Limit				50 MMSCFD Fuel Gas Limit			
	Number of Units	Total Capacity (MW)	Footprint (m <sup>2</sup> )	Capex Cost Adjustment (US\$ millions)	Number of Units	Total Capacity (MW)	Footprint (m <sup>2</sup> )	Capex Cost Adjustment (US\$ millions)
SGT 400 SC	10	108	25,000	3.4	18	194	36,000	4.9
SGT 400 CC	10	155	44,000	5.9	18	279	57,000	7.7
LM 2500 SC	6	127	22,000	3.0	10	212	32,000	4.3
LM 2500 CC	6	180	35,000	4.7	10	300	54,000	7.3
Wartsila	9	153	24,000	2.8	15	255	30,000	3.8

**Note**

The Capital Cost Adjustment values included in Table 2.5 are Site-Specific.

**2.2.5 Cost-Benefit Analysis of the Alternatives**

For the options described in the previous section, K&M conducted an economic analysis that calculated the Levelized Cost of Energy (LCOE) for the entire Guyana's electrical system. The LCOE was calculated for each option with 30 MMscfd and 50 MMscfd gas supply over the forecast period of 28 years (2020 – 2047). The LCOE is defined as the average unit cost of electricity generated by all the generating facilities considered for a particular option, calculated as the PV (Present Value) of total electricity costs divided by PV of total electricity demand over the forecast period (expressed in US\$ per MWh). For each of the options the option evaluation model calculates capacity factors for different technologies covering the demand. The capacity factors are compared to typical availability achievable by gas fired power plants, which is typically guaranteed to be above 92% by IPP developers. The calculated capacity factors are all below 92%, which means that they all are achievable.

The summary ranking based on LCOE for the different options is presented in Figure 2.7.

**Figure 2.7: Cost Ranking of Options (LCOE - US\$/MWh)**

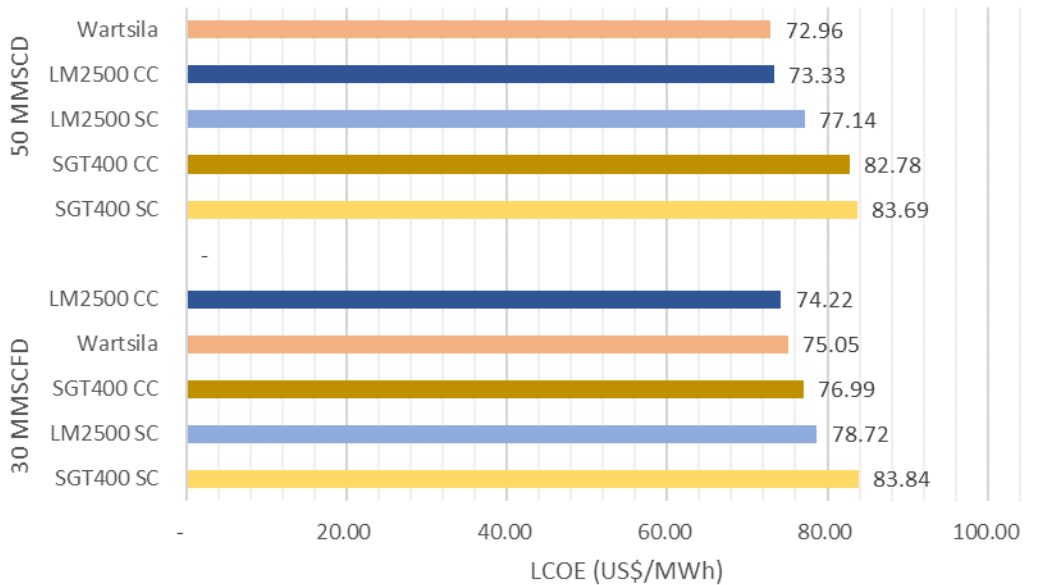

The main results and recommendations from the cost-benefit analysis are:

- LCOEs for the 50 MMscfd scenario are lower than for the 30 MMscfd scenario for all the options. This can be explained by higher generation on lower cost Natural Gas for the 50 MMscfd scenario. However, these differences are relatively small.
- Wartsila and the LM2500 combined cycle are the two least cost options for 50 MMscfd and 30 MMscfd gas supply scenarios, respectively.
- The reason for LM2500 CC resulting in the lowest LCOE of US\$74.22/MWh for the 30 MMscfd scenario is because it has the highest installed capacity (180 MW) compared to all the other options. Even though the LM 2500 CC option has a higher upfront CAPEX than simple cycle and Wartsila options, the larger installed capacity coupled with lower heat rates result in more efficient utilization of Natural Gas and make up for the higher upfront investment. The unit system electricity cost for Wartsila engines is a close second to the LM 2500 CC at US\$75.05/MWh.
- For the 50 MMscfd gas supply scenario, the Wartsila option results in the lowest system unit cost of electricity at US\$72.96/MWh followed closely by LM 2500 CC at US\$73.33/MWh. The results for the 50 MMscfd scenario are different from the 30 MMscfd scenario due to the relatively smaller size and CAPEX of Wartsila option compared to the LM 2500 CC option while generation profiles of two options are similar. Impact of increased PV Solar capacity

During the kickoff mission, it was mentioned that GPL is considering installing an increased amount of PV Solar in the future. To address this development, K&M also conducted the analysis on scenario with increased PV Solar penetration on the total system unit cost of electricity and the results are presented in Figure 2.8

**Figure 2.8: Cost Ranking of Options - 60 MW Solar (LCOE - US\$/MWh)**

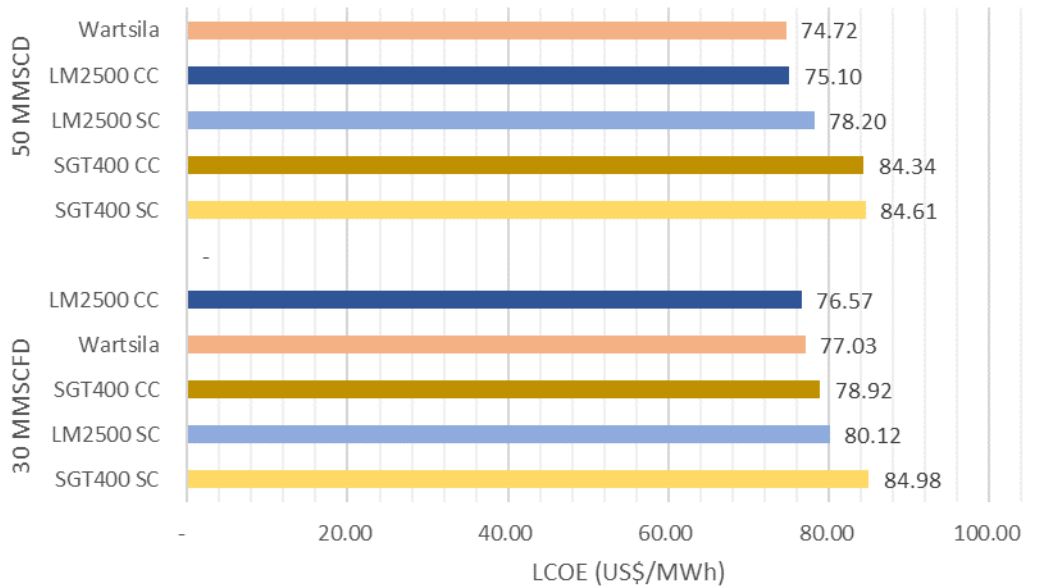

As we can see from Figure 2.8, the increase in PV Solar capacity to 60 MW has a very minimal impact on the overall system cost for both gas supply scenarios. The system costs for different options in 30 MMscfd and 50 MMscfd gas supply scenario increase by approximately US\$2/MWh and US\$1.5/MWh respectively. For other PV Solar capacities like 30 MW and 90 MW, we can expect minimal variation in system cost numbers.

The ranking for different options does not change with increased PV Solar capacity with Wartsila and LM2500 CC as the least cost options for both gas supply scenarios.

### 2.2.6 Emission Reduction and Climate Benefits

Based on the generation dispatch estimates developed for the preferred options, generation from the new Natural Gas power plant will replace most of existing HFO generation. The environmental benefits resulting from the new gas plant are summarized below.

- Reduction of greenhouse gasses (GHG) emissions from power generation, due to the comparatively lower carbon content of Natural Gas. The total GHG emissions reduction for a period between 2023 and 2035 expressed in tonnes of CO<sub>2</sub>-equivalent (CO<sub>2</sub>-e) are estimated at approximately 8.7 Million tonnes for the 30 MMscfd gas supply scenario, and 6.1 Million tonnes for the 50 MMscfd gas supply scenario.
- Significant reduction of SO<sub>x</sub> and NO<sub>x</sub> contaminant emissions. The amount of SO<sub>x</sub> emissions reduction between 2023 and 2035 are approximately 198 and 200 thousand tonnes for 30 and 50 MMscfd gas supply scenarios, respectively. Similarly, the NO<sub>x</sub> emissions are reduced by 58 and 47 thousand tonnes for the 30 and 50 MMscfd gas supply scenarios, respectively.
- The economic benefit due to reduction in emissions for a period between 2023 and 2035 is estimated, depending on the technology and available gas quantities, between approximately US\$150 and US\$234 million due to greenhouse and between approximately US\$70 and US\$80 million due to NO<sub>x</sub> and SO<sub>x</sub> emission reduction.

## 2.2.7 Conceptual Design

The conceptual design in this Study is based on the two technology options recommended based on the cost-benefit analysis of different options — Wartsila 17 MW dual fuel (natural gas and HFO) reciprocating engines (RICE) and GE LM2500 combined cycle. For each of the options, conceptual designs are developed for 30 MMscfd and 50 MMscfd natural gas supply scenarios. Power evacuation arrangements assume that power generated by the plant will be evacuated at 230 kV voltage for both options under 30 MMscfd and 50 MMscfd natural gas supply scenarios.

Major considerations in determining the number and size of individual generating units and overall capacities for each option included the following:

- The trip of any single unit should result in a loss of capacity less than 10% of system peak load;
- The installed reserve margin should be at least 15% of peak generating capacity or the total capacity of the two largest generating units, whichever is higher.

The summary of key plant characteristics and design assumptions are provided in

Table 2.7 below:

**Table 2.7: Key Characteristics and Assumptions**

Parameter	Units	Wartsila 30 MMscfd	RICE 50 MMscfd	LM2500 CC 30 MMscfd	LM2500 CC 50 MMscfd
Number of engines	No	9	15	6	10
Net Plant Output	MW	152.5	254.2	182.6	304.3
Full Load Heat Rate	Btu/kWh	7724	7724	6780	6780
Hourly Gas Demand at Full Load	MMBtu/hr (LHV)	1178	1963	1238	2063
Daily Gas Demand	MMBtu/day (LHV)	28,300	47,100	29,700	49,500
	Scfd	28.6	47.5	30.0	49.9
Approximate Land Requirements for Power Plant	m <sup>2</sup>	24,000	30,000	35,000	54,000
Total Owner's Capital Cost	million USD	164	261	268	429
Normalized Capital Cost	USD / kW	1075	1026	1469	1410

## 2.2.8 Cost Estimate

Cost estimates for the power plant for the two supply scenarios were developed for both options – Wartsila 17 MW dual fuel reciprocating engines (RICE) and GE LM2500 combined cycle – using the conceptual design developed in Section 11.

The estimates include site specific preparation requirements based on the assumed generic site in Guyana which make up part of the "Civil" and "Buildings & Structures" figures below in the summary table. Site specific preparation requirements include Site Remediation, Shore Protection, and a Barge Unloading Facility since it is assumed that the site will be located close to the shore with limited site access by road for equipment and material deliveries<sup>3</sup>. Prior experience with similar projects were used to estimate these components. The conceptual design and cost estimates consider the possible climate change impacts such as rising sea level and ambient temperature when evaluating overall capital cost and performance of the new power plant.

The summary of major capital costs for the options is presented below:

---

<sup>3</sup> It is a common practice to unload equipment in major port and deliver it to the site by barges for projects with limited site access by road.

**Table 2.8: Summary of Major Capital Costs**

Project Cost Summary All Costs in US\$		Wartsila 17 MW Dual-Fuel RICE		GE LM2500 Combined Cycle	
		30 MMscfd	50 MMscfd	30 MMscfd	50 MMscfd
I.	Specialized Equipment	80,492,612	132,488,403	129,004,593	214,288,255
II.	Other Equipment	2,039,058	2,928,692	9,624,888	14,741,391
III.	Civil <sup>4</sup>	12,961,491	19,019,454	18,703,642	28,470,371
IV.	Mechanical	7,540,735	12,576,706	13,311,869	23,265,088
V.	Electrical Assembly & Wiring	2,807,528	5,136,472	4,971,196	9,557,983
VI.	Buildings & Structures	17,771,137	20,156,757	14,323,646	14,527,030
VII.	Engineering & Plant Startup	4,247,300	5,604,400	12,047,150	15,833,300
<b>Subtotal – Contractor's Internal Cost</b>		<b>127,859,860</b>	<b>197,910,883</b>	<b>201,986,984</b>	<b>320,683,417</b>
VIII.	Contractor's Soft & Misc. Costs	24,156,012	41,255,279	44,046,589	72,804,716
<b>EPC Contractor's Price</b>		<b>152,015,872</b>	<b>239,166,162</b>	<b>246,033,573</b>	<b>393,488,132</b>
IX.	Owner's Soft & Misc. Costs	11,881,428	21,524,955	22,143,022	35,413,932
<b>Total – Owner's Cost</b>		<b>163,897,300</b>	<b>260,691,117</b>	<b>268,176,594</b>	<b>428,902,064</b>
Net Plant Output (MW)		152.5	254.2	182.6	304.3
<b>Price per kW – EPC Contractor (USD per kW)</b>		<b>997</b>	<b>941</b>	<b>1,348</b>	<b>1,293</b>
<b>Price per kW – Owner (USD per kW)</b>		<b>1,075</b>	<b>1,026</b>	<b>1,469</b>	<b>1,410</b>

<sup>4</sup> Civil costs assume that the plant will be located on a generic site in a low lying marshy area near the coast.



## 2.2.9 Financing Options Analysis

K&M considered two methods for financing the Project. The first method is to pursue a GPL corporate financing, such as a long-term balance sheet financing (corporate loans or bonds), and the second method is to pursue a non or limited recourse financing (i.e. "Project Finance"). Corporate Financing is frequently used for projects owned by government owned utilities around the world. Under this method of financing, GPL would have ownership and control of the Project and would select an EPC Contractor to design, procure, and construct the Project and potentially operate the Project during its useful life. Under this approach, GPL will be fully exposed to the Project's development, construction, and operation risks while the Project's capital cost will be reduced due to elimination of a material portion of the "Owner's soft and miscellaneous costs" shown in Table 2.8 above. Also, the corporate debt holders would have recourse to the assets of GPL as the corporate borrower.

To secure a Project Financing, the Project would require an experienced and proven independent power producer (IPP) as sponsor establishing a special purpose vehicle to be the borrower. As compared to a corporate loan transaction, a Project Financing will typically require, among other things, (i) a more detailed due diligence review, (ii) a more comprehensive risk mitigation plan, (iii) a contract structure and contract provisions which optimally allocate risk among the project participants, and (iv) a robust security package to provide quick and easy access to a project's assets to protect the lenders interests. With this financing option GPL would need to select a qualified IPP to be responsible for the development, financing, design, procurement, construction and operation of the Project during a pre-determined period (usually 20 to 25 years) and purchase capacity and energy generated by the Project under a long term Power Purchase Agreement (PPA). Under this approach, most of the Project development and the entire project construction and operation risk will be assumed by the IPP, but the Project's capital cost will likely be higher than for a Corporate Financing approach by an amount close to the "Owner's soft and miscellaneous costs" shown in Table 2.8 above.

Given the Project capital requirements (US\$ 163 Million to US\$ 429 Million), K&M believes that it may be difficult for GPL to raise the required amounts using a Corporate Finance approach and GPL should develop this Project using Project Finance. However, K&M's financial analysis in this report analyzes both corporate financed and project financed structures. A final decision regarding the method of financing to be used for the Project should be made by the GoG and GPL based on economic, financial, and policy considerations after thoroughly considering both Corporate Finance (EPC procurement) and Project Finance (IPP procurement) options.

## 2.2.10 Financial and Economic Analysis

For each of the gas supply scenarios and technology options presented in Table 2.7 above K&M conducted the financial analysis for three scenarios – one scenario assuming that the Project will be financed as a Project Finance transaction and two scenarios assuming corporate financing using either corporate or DFI loans.

K&M conducted the financial analysis using a Base Case set of assumptions. The major elements of the Base Case include technical configuration, commercial and financial, and tariff. The Base Case assumptions are described in detail in Section 14.

The Project is assumed to have a commercial structure under which all revenues are derived from the sale of electricity to GPL for the IPP or to GPL's customers for a corporate financed approach.

The Project is not designed to require any direct subsidy from the Government to supplement its revenues. The main commercial assumptions used are:

- Leverage Ratio: 70%
- Loan interest rate: 3.5% per year for IPP (assuming DFI financing) and EPC option with sovereign guarantee and DFI financing (based on past GPL projects); 8% for EPC option with commercial bank financing.
- Required return on equity: 15% (typical for IPPs in developing countries) and 8% (typical return for corporate finance)
- Loan tenor: 15 years for IPP and EPC commercial financing option and 25 years for EPC with sovereign guarantee and DFI financing.

### 2.2.10.1 Results

#### Tariff Analysis

The resulting average tariffs over the Project life for different financing approaches and gas availability scenarios are presented in Table 2.9 below. The EPC options consider two debt financing scenarios – commercial bank finance with loan tenor of 15 years and interest rate of 8% and DFI financing coupled with sovereign guarantee resulting in loan tenor of 25 years and interest rate of 3.5%.

**Table 2.9: Tariff Analysis**

Average Tariff (US cents/kWh) Approach	Wartsila		LM2500 CC	
	30 MMSCFD	50 MMSCFD	30 MMSCFD	50 MMSCFD
IPP	7.1	6.95	7.49	7.35
EPC (commercial loan)	6.64	6.55	6.8	6.7
EPC (DFI loan)	6.17	6.09	6.1	6.0

The following are conclusions from the tariff analysis:

- For the scenarios with loan tenor of 15 years for both IPP and EPC structures the Wartsila options result in a slightly lower per unit tariff than LM 2500 CC options. Even though the LM 2500 CC has a better heat rate than Wartsila RICE, the comparatively lower capital costs for the Wartsila option drives down the per unit tariff.
- For the EPC scenario with 25 year loan tenor based on assumption that the Government of Guyana provides sovereign guarantee and the project debt is financed by DFIs, the average tariff decreases by between approximately 0.5 US cents/kWh for RICE option to 0.7 US cents/kWh for CC options compared to the commercial loan option. Additionally, LM2500 CC option becomes slightly less expensive for DFI option as better heat rate and resulting reduction in fuel cost compensates for higher capital cost when debt repayment is spread over a longer period.
- The tariffs for the EPC financing model are lower than the tariffs for the IPP financed model. This is expected since the corporate finance using EPC has lower development and financing costs and cost of capital. However, as explained in Section 13 corporate finance using EPC is riskier as all the project completion and development, construction, and operation risks will be

borne by GPL. Also, it might be difficult for GPL to raise the required capital requirements for the Project using a Corporate Finance approach.

### Life Time Cost

Life cycle cost analysis is a method for expressing the entire cost of the Project over its expected useful life in a single cost in today's dollars. It is calculated by taking the present value of all costs (including Capital Costs, O&M Costs, Fuel Costs, etc.) incurred over the life of a project at the Project's Weighted Average Cost of Capital. The results of the Life Cycle Cost Analysis are provided in Table 2.10.

As can be seen, the life time costs for the Wartsila RICE options are slightly lower than the LM 2500 CC options, which is also reflected in the lower per unit tariff discussed previously.

**Table 2.10: Life Cycle Cost Analysis Results**

Description	Wartsila RICE		LM 2500 CC	
	30 MMSCFD	50 MMSCFD	30 MMSCFD	50 MMSCFD
<b>IPP</b>				
<b>Life Cycle Costs</b>	669 Million USD	983 Million USD	745 Million USD	1,056 Million USD
<b>Upfront Capital Costs including interest during construction</b>	174 Million USD	277 Million USD	284 Million USD	456 Million USD
<b>EPC (Commercial Loan)</b>				
<b>Life Cycle Costs</b>	645 Million USD	950 Million USD	706 Million USD	1,006 Million USD
<b>Upfront Capital Costs including interest during construction</b>	171 Million USD	271 Million USD	273 Million USD	440 Million USD
<b>EPC (DFI Loan)</b>				
<b>Life Cycle Costs</b>	630 Million USD	927 Million USD	683 Million USD	970 Million USD
<b>Upfront Capital Costs including interest during construction</b>	162 Million USD	255 Million USD	258 Million USD	413.7 Million USD

The following are conclusions from the life time cost analysis:

- The life time cost for Wartsila RICE options are lower than for the LM2500 CC options due to their lower capital costs.
- The life time cost for the IPP options are higher than the life time cost for the EPC options.
- The life time cost for the EPC option using DFI loan with favorable terms is lower than for the EPC option using commercial loan with typical commercial terms.

## 2.2.11 Grid Impact Analysis

A power flow study was used to analyze the power evacuation from the new gas fired power plant to serve grid load while displacing the present conventional generation in Guyana.<sup>5</sup> Two future-year load scenarios were studied: year 2023 projected loads (the expected year of plant commissioning) and year 2035 projected loads as a study horizon-year. For each of those study years two gas supply levels were analyzed: 30 MMscfd and 50 MMscfd supply scenarios. Additionally, each year and gas supply level was analyzed under three separate injection scenarios:

- 1 Inject the new plant power output on a new 69 kV line constructed between the Good Hope and the Columbia substations and a new 69 kV line constructed between the new gas fired power plant and the New Sophia substation;
- 2 Inject the new plant power output on a new 230 kV bus proposed to be constructed at the New Sophia substation; and
- 3 Inject the new plant power output simultaneously to the Good Hope – Columbia 69 kV line and the 230 kV bus at the New Sophia substation.

K&M's CAPEX estimate for different power evacuation scenarios is presented in Table 2.11 below.

**Table 2.11: Summary of Grid CAPEX Investment Scenarios (all values in US\$)**

Evacuation System Buildout Voltage Level	170 MW, 30 MMscfd Investment Level	272 MW, 50 MMscfd Investment Level
69 kV Only	61,852,000	110,872,000
230 kV Only	89,000,000	90,366,000
69kV and 230 kV	77,900,000	84,672,000

The above estimates includes upgrades to the existing substations. A more detailed cost estimate of grid CAPEX investments for different scenarios is presented in Section 16 of this report.

Based on the results of K&M's analysis, it can be concluded that:

- Plant output evacuation of up to 331 MW can be achieved at either voltage levels studied.
- Evacuating lower plant output levels over a 69 kV-only system results in significant CAPEX savings compared to the other two alternatives studied.
- At higher plant output evacuation levels, a combination of 69 kV and 230 kV presents the lowest CAPEX for the system topology and contingencies studied.
- The downside of a 69 kV-only option is that the resulting transmission system is not amenable to interties with neighboring countries or with the Arco-Norte interconnection—this limits the system future expansion capability.
- At lower plant output evacuation levels, 69 kV-only presents the lowest CAPEX for the system topology and contingencies studied.

<sup>5</sup> The power flow model is submitted as a separate set of files accompanying this report.

- Though the 69 kV is the least expensive option for 30 MMscfd scenario and a combination of 69 kV and 230 kV is the least expensive option for 50 MMscfd scenario, to ensure that the system is capable to possible future connection to Arco Norte, a combination of 69 kV and 230 kV option is recommended as a preferred option for both scenarios.

A more detailed description of the options considered including grid schematic diagrams are presented in Section 16 of this report. The grid load flow model is provided in electronic format separately as it can only be opened and used with specialized PSS/E power modeling software.

## **2.2.12 Implementation Plan**

K&M estimated the steps and the timeline required for developing the Project. According to K&M's estimate, for the Project developed as an IPP the commercial operation date for the first phase can be achieved within approximately 60 months from the date of approval of this Feasibility Study and a selected site for an IPP option and 54 months for an EPC option.

## **2.2.13 Conclusions and Recommendations**

### **2.2.13.1 Conclusions**

The following are the conclusions resulting from the results of the analysis performed in the above sections of the report.

- 1 The current installed capacity of 136.9 MW is not adequate to cover existing demand due to the low availability and planned retirements of existing units, transmission system constrains, and unserved demand that would connect to the grid if it has higher reliability of power supply.
- 2 DBIS system requires addition of at least 250 MW of new capacity by 2035 to satisfy growing electricity demand.
- 3 Additional HFO-based capacity will have to be installed by 2026 in case there are delays with development and construction of hydropower capacity for 30 MMscfd natural gas scenario.
- 4 Though it is likely that recoverable natural gas reserves will be sufficient to support required gas supply for both 30 MMscfd and 50 MMscfd over the useful life of new gas fired power plant, there is no reliable information regarding recoverable natural gas reserves in Stabroek field. Gas reserve information must be confirmed with the gas supplier prior to start of development of new gas fired power plant.
- 5 Increased penetration of solar generation will not impact the dispatch from the new power plant but will reduce the consumption of HFO generation.
- 6 Conversion of existing HFO units is not feasible due to high conversion costs and difficulties in transportation of natural gas to existing units
- 7 CCGT and RICE are the best two technology options for the new gas fired power plant.
- 8 Using natural gas as fuel for generating capacity additions will provide significant environmental benefits.
- 9 Using RICE technology results in slightly lower cost of electricity generated by the Project.
- 10 EPC option for Project implementation results in lower overall electricity cost and shorter implementation schedule but allocates more risks to GPL.

- 11 EPC option with DFI financing results in the lowest overall electricity cost, but increases the project implementation risk allocated to the GoG.
- 12 Injecting the new plant power output simultaneously to the Good Hope – Columbia 69 kV line and the 230 kV bus at the New Sophia substation seems to be an optimum solution.

#### **2.2.14 Recommendation**

- 1 K&M recommends using RICE technology for the new power plant as it results in slightly lower cost of electricity for majority of the options considered, higher fuel flexibility as it has the ability to run on lower cost HFO, and the loss of a single RICE unit will not cause a significant strain on the system due to its relatively lower unit size.
- 2 It is extremely important for the Government of Guyana to work with the prospective gas supplier to obtain firm quantity of available natural gas reserves for power generation.
- 3 The hydropower plant is expected to come online by 2026. Any delays in the construction of the hydropower plant will result in firm capacity deficits that would require additional HFO-based generation.
- 4 The new power plant will constitute a significant portion of Guyana's electricity generation and any disruption in supply of natural gas could significantly impact the cost and availability of electricity, especially in the case of higher gas supply volumes. This risk will be reduced if the Arco Norte transmission interconnection project is implemented.
- 5 The Government of Guyana should make a decision on whether the project should be implemented using IPP or EPC model based on cost, risk allocation and Guyana and GPL fiscal capacity considerations and Government's overall policy objectives related to inviting private sector participation in power industry.
- 6 K&M recommends the Government of Guyana to select an IPP developer or an EPC contractor using competitive bidding process and to engage an experienced Transaction Advisor (in case of IPP) or an Owner's Engineer (in case of EPC) to assist the Government of Guyana during the bidding process and project implementation.
- 7 The new power plant should be a multi-unit facility connected to the grid by a double circuit line, which mitigates the risk of losing the entire or significant portion of the facility with the loss of a single unit or one of the circuits.
- 8 K&M recommends that GPL construct a 69 kV-only evacuation system for initial (lower) plant output, over a single 1-927 AAAC line constructed between Good Hope and Columbia (constructed at 115 kV insulation, clearance and strength), and a single 69 kV line (constructed at 230 kV insulation, clearance and strength) between the plant and New Sophia. When those line capacities are close to reaching their limit, the 230 kV evacuation system should be constructed to augment the 69 kV system.
- 9 K&M recommends that any 69 kV infrastructure built be constructed at 115 kV insulation, clearance and strength levels, but operated at 69 kV until a voltage conversion occurs.
- 10 K&M recommends that unless rights-of-ways are difficult or expensive to obtain, multiple circuits between substations are constructed as separate pole lines separated by a distance of at least one span length to increase system reliability and resilience.

### 3 Introduction

---

The recent discovery of off-shore oil and gas deposits has presented an opportunity for Guyana to transform its energy sector. The availability of abundant indigenous Natural Gas could allow Guyana to move away from the current diesel/HFO based generation and switch to Natural Gas, which is environmentally cleaner and potentially cheaper. The switch to Natural Gas will substantially reduce emissions from Guyana's Power sector and act as a bridge for the GoG to meet its renewable energy targets, as outlined in the Government's Green State Development Strategy, in the most cost-effective way.

IADB is assisting the Government of Guyana in developing a strategy for the optimal use of indigenous gas sources for power production. As part of this program, IADB selected K&M Advisors via a competitive selection process to conduct the Gas to Power Feasibility Assessment. The Consulting Agreement between IADB and K&M was signed on August 14, 2018.

The assignment is planned to be performed in three parts as follows:

- **Part 1** consists of preparatory activities and will include a review of the existing studies and information, initial meetings with major energy sector stakeholders, analysis of electricity and Natural Gas supply and demand situation, technical review for converting existing diesel generators to Natural Gas, analysis of the existing power generation, transmission, and distribution infrastructure, and review of best practices for Natural Gas to power generation from other countries.
- **Part 2** will include technical and economic evaluations of different options for gas to power technologies, size, location, and configuration of the new power plant, evaluation of gas to power options, optimal transmission voltage and substation requirements, evaluation of options for delivery of Natural Gas to the power plant, estimation of environmental benefits, and selection of the two best options for implementation.
- **Part 3** will include complimentary analysis that would further advance project development process. The tasks that will be performed during Part 3 will include the assessment of transmission system upgrade requirements and system stability, development of the GPL generation dispatch model, preparation of the outline of commercial terms related to the gas supply agreement, evaluation and screening of project financing options, recommendations for changes in the regulatory framework, and development the project implementation roadmap and timeline for the selected option(s).

This Final Report is prepared in accordance with the Work Plan agreed to by the IADB, GoG, and K&M and covers the following topics:

- Section 4: electricity Supply and Demand Analysis
- Section 5: Gas Supply and Demand Analysis
- Section 6: Analysis of Viability of Conversion to Existing Facilities to Dual Fuel Operation
- Section 7: New Power Plant Size, Site, and Technology Options Analysis
- Section 8: Gas Availability, Properties, and Delivery Arrangements
- Section 9: Cost Benefit of the Alternatives.
- Section 10: Emission Reductions and Climate Benefits

- Section 11: Conceptual Design for two best technology options
- Section 12: Cost Estimate
- Section 13: Financing Options Analysis
- Section 14: Financial and Economic Analysis
- Section 15: Dispatch Model
- Section 16: Grid Impact Analysis
- Section 17: Terms of Gas Supply Contract
- Section 18: Regulatory Framework Review
- Section 19: Implementation Roadmap
- Section 20: Conclusions



## 4 Electricity Supply and Demand Analysis

This section presents the results from K&M's analysis of the Electricity Demand and Supply in Guyana. K&M used the following information in our assessment

- Hourly load values for the Demerara Berbice Interconnection System (DBIS) for 2017
- Information on the existing generators in Guyana, including heat rates and year of operation
- Generation expansion plan presented in Expansion study updated in 2018 (further referred to as Expansion Study).

The Electricity Supply and Demand Analysis consists of three sections. Section 4.1 discusses the current electricity supply and demand, Section 4.2 presents the demand growth and generation capacity forecasts, and Section 0 discusses the forecasted electricity demand and supply for 2023 and 2035.

### 4.1 Current Supply and Demand

#### 4.1.1 Existing Generators

The Guyana electric power system consists of the DBIS, the Essequibo region, the Hinterlands, and several self-generation facilities. Since DBIS is the main electric system in Guyana constituting 95% of all power generated in Guyana<sup>6</sup> and there are plans for connecting Linden power system to DBIS<sup>7</sup>. Subsequent analysis in this section focuses on the demand and supply scenarios for DBIS with Linden. As of the latest available information, there are a total of 9 power plants in the DBIS with a combined capacity of 136.9 MW and their details are provided in Table 4.1 below:

**Table 4.1: Existing Generators - DBIS**

Name	Fuel	Capacity	Heat Rate (Btu/kWh)	Commissioning Year
Canefield M5**	HFO	5.50	7,932	2018
Demerara Power 3 (Kingston 2)	HFO	36.30	7,960	2009/2011
Demerara Power 4 (Vreed-en-Hoop)	HFO	26.10	8,100	2014
Skeldon	HFO	10.00	8,151	2007
Demerara Power 2 (Kingston 1)	HFO	22.00	8,270	1997
Canefield M3*	HFO	4.50	8,402	1976

<sup>6</sup> Update to Expansion Study. Page 22

<sup>7</sup> Update to Expansion Study. Page 46

Name	Fuel	Capacity	Heat Rate (Btu/kWh)	Commissioning Year
Demerara Power 1 (PPD 1 Garden of Eden)	HFO	22.00	8,613	1994/1996
Onverwagt*	LFO	2.00	10,016	Not available
Garden of Eden*	LFO	8.50	10,327	Not available
	<b>Total</b>	<b>136.9</b>		

\* Expected to be retired soon

\*\* Canefield M3 and Canefield M5 are part of the Canefield Power Station.

As seen in the table above, GPL has installed 77.9 MW of new HFO power plants since 2007 and plans to add 8.7 MW of HFO generation in 2019. In addition to the HFO plants mentioned above, there is 30 MW of Bagasse based generation at Skeldon, but that plant is not operational at the moment.

## 4.1.2 Electricity Demand Analysis – 2017

The electricity demand in Guyana is relatively flat, with 90% of load falling between 75 MW and 114 MW (peak demand for 2017). The required firm capacity for Guyana is 131 MW (114 MW peak demand + 17 MW reserve capacity) and as mentioned in previous section the available firm capacity in DBIS is 137 MW providing a surplus of 6 MW. Even though, the available firm capacity in DBIS is sufficient for the peak demand in Guyana, the loss of one or two larger units can cause considerable stress on the system. Also, there is a single circuit line connecting Demerara Power 4 (Vreed-en-Hoop) power plant to the DBIS system and in case of line disruption, the system loses 26 MW which can cause system-wide blackouts.

### 4.1.2.1 Load Duration Curve

Figure 4.1 shows the Load Duration Curve for 2017. K&M's analysis assumed that the future shape of the load duration curve will remain the same with all the loads increasing with the increase in peak load projected by the Expansion Study. The shape of the curve may be impacted by changes in the GPL consumer base; analysis of such changes is beyond the scope of this study. By 2023, the firm capacity requirement for Guyana increases to 176 MW—requiring an additional 45 MW of firm capacity.

**Figure 4.1: Load Duration Curve - 2017**

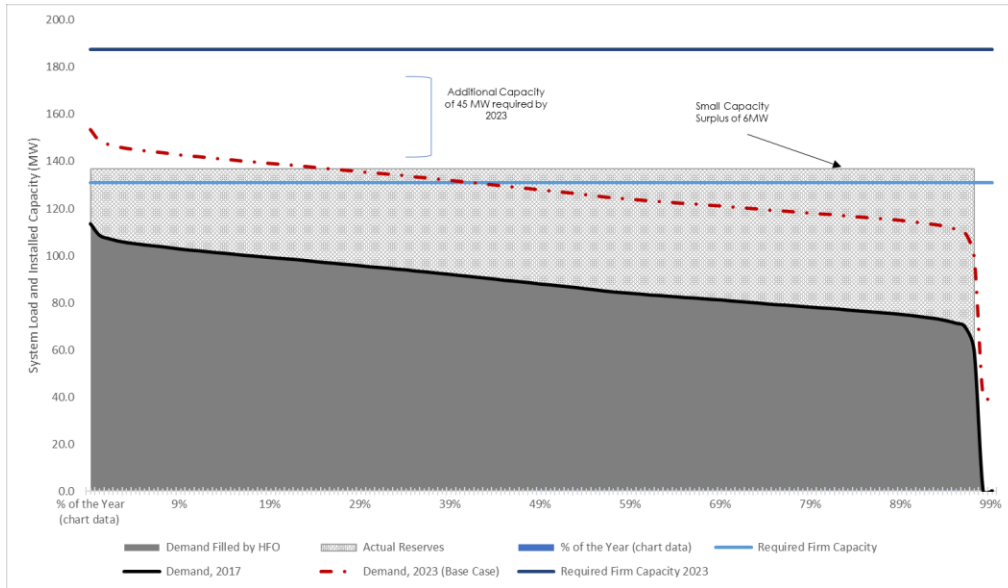

**4.1.2.2 Daily Load Curves**

Guyana's average daily load fluctuates between a low of 73 MW and a high of 102 MW. The low of 73 MW occurs during the night between 5AM and 6AM, when most offices and businesses are closed. The load starts to increase steadily and reaches the high of 102 MW between 6 to 7 PM and stays around that level till 10 PM. Guyana's load also shows some seasonal variation as the months of Jan-Mar are below the annual average, the months from Apr-Sep are around the average, and the load increases in Oct-Dec (see Figure 4.2).

Figure 4.2 also shows the peak day load which occurred on November 17<sup>th</sup>. The peak day load has a similar load profile to the average daily load curve and fluctuated between a low of 81 MW between 5-6 AM in the morning and reaching the peak of 114 MW at 7 PM.

**Figure 4.2: Annual Average Daily Load Curves**

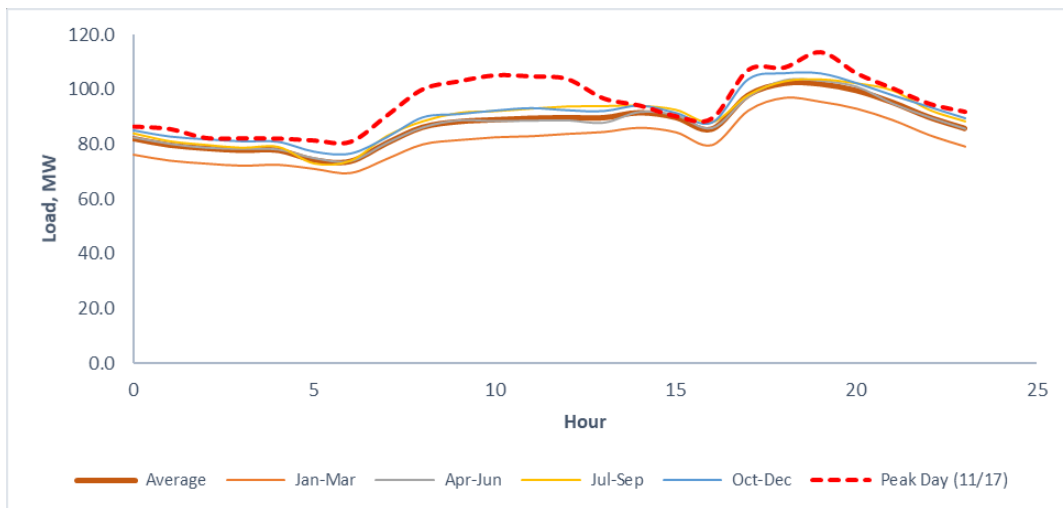
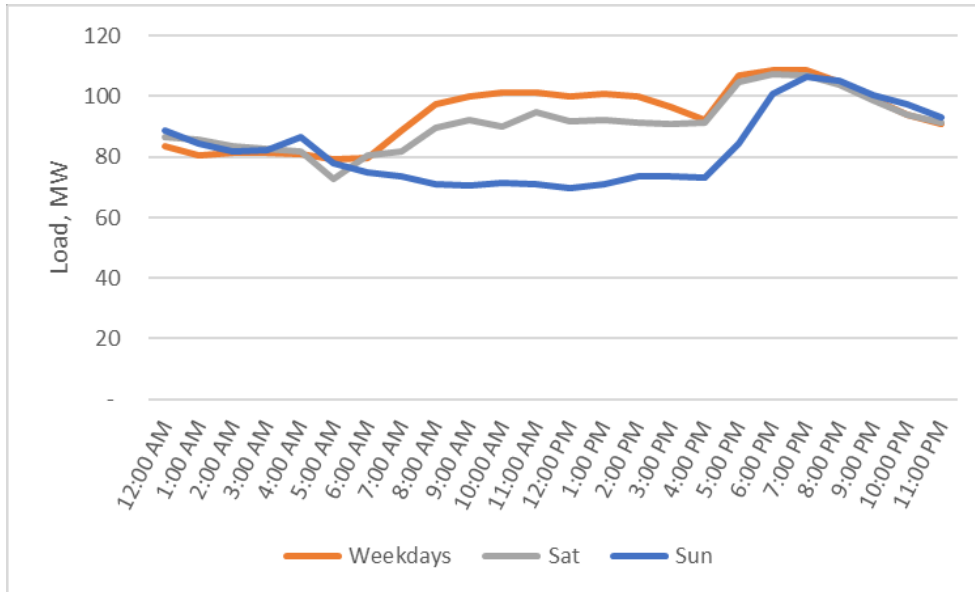
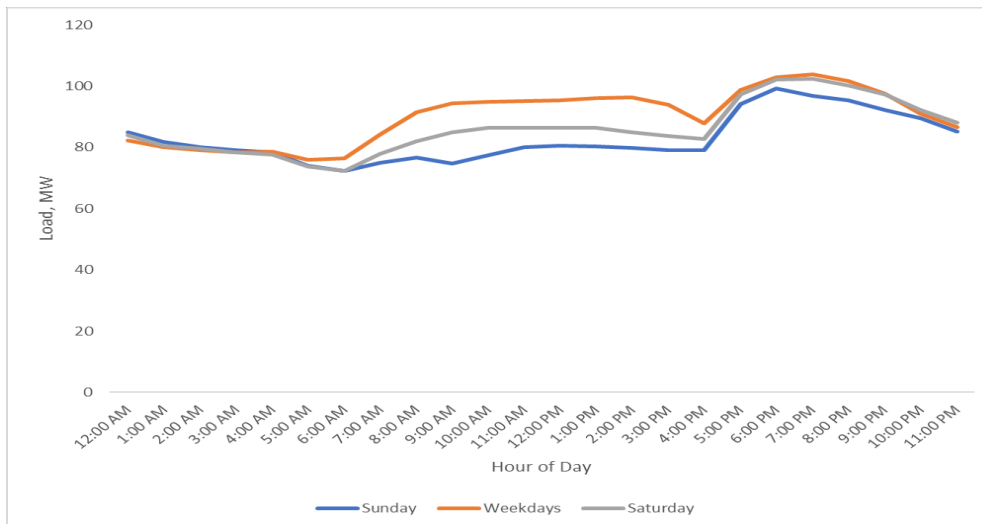

Figure 4.3 and Figure 4.4 below shows the daily load curves for different days of the week for the peak and an average week in 2017. The daytime loads on Saturday and Sunday are significantly lower than during the weekdays. The nighttime and evening loads follow a pattern similar to the load patterns of weekdays.

**Figure 4.3: Daily Load Curves by Day of the Week for the 2017 Peak Load Week**



**Figure 4.4: Daily Load Curves by Day of the Week for an Average Week**



## 4.2 Demand Growth and Generation Capacity Forecasts

The demand growth data and generation capacity additions presented in this analysis are based on the "Delayed Base Case" Scenario in the Expansion Study. The Delayed Base Case Scenario assumes that the electricity demand growth in Guyana would lag behind the expected growth in GDP resulting from the recent oil discoveries off Guyana's coast and the associated investments.

The authors of the Expansion Study based this approach on their experience with demand growth in other countries with power sectors similar to power sector in Guyana. K&M considers that this approach is reasonable.

Generation capacity analysis is based on the data provided by GPL on the existing generators, firm, and renewable capacity additions forecasted by the Expansion Study. The additional Natural Gas capacity is modified based on K&M's analysis of technology options and the maximum capacity that can be supported by 30 MMscfd and 50 MMscfd natural gas supply scenarios based on heat and material balance calculations.

Section 9 further analyzes the generation for different technologies and capacities of new power plant as part of the gas power plant cost-benefit analysis. As Section 9 shows, the two best technology options for the new gas fired power plant are:

- a) dual fuel Wartsila reciprocating internal combustion engines (RICE) with capacity of 17 MW, the option considered by the Expansion Study, and
- b) combined cycle based on GE LM2500 gas turbine with a single unit capacity of 30 MW when operating in combined cycle.

The purpose of this section is i) to review the demand growth and associated firm capacity requirements including reserve margin for two options, ii) to determine whether this demand can be satisfied by planned capacity additions, and iii) to estimate the expected annual electricity production from different sources. The analysis in this Section and the Final Report treats HFO, Gas, and Hydro resources as firm generating capacity. Intermittent renewables (solar and wind) and resource constrained by seasonal availability of fuel (biomass) generating options are not considered as firm sources.

#### **4.2.1 Approach to Estimating Reserve Margin**

For the purposes of this analysis the reserve margin is calculated as 15% of the peak demand (the approach used in the Expansion Study) or 2 times the capacity of the largest unit (the deterministic method used by GPL and a number of other utilities in many countries around the world), whichever is higher. The Expansion Study sets 15% target reserve margin as a typical target used by power utilities. The method of setting the required reserve margin at 2 times the capacity of the largest unit is based on a requirement that the system should be capable of covering peak load in a situation when one of the largest units experiences a forced outage and another largest unit has maintenance outage. **K&M considers that setting the reserve margin at a value that is either 15% of the peak capacity or 2 times the capacity of the largest unit, whichever is higher, is a reasonable approach.**

It should be noted that another commonly used method for calculating reserve margin target is a probabilistic method based on the Loss of Load Expectation (LOLE) analysis. This method determines a more precise value for the required reserve margin and may further optimize reserve margin investment requirements. Conducting such analysis is beyond the scope of this study. GPL may consider engaging a power system reliability expert to conduct such LOLE analysis to further optimize the reserve margin requirements and associated investments.

#### **4.2.2 Demand and Supply Analysis for Wartsila RICE Technology Option**

The results of the demand and supply analysis for Wartsila 17 MW RICE options are presented below. In addition to the generation expansion, the relevant tables also show required capacity

(including reserves) and the difference (surplus or deficit) between the available and required firm capacities. This difference is an important metric that shows whether the system has enough firm capacity to cover the expected peak demand during normal operation and in case of generating unit outages. The analysis distinguishes between firm capacity, which includes HFO, Gas, and Hydro, and total capacity that includes intermittent sources like Biomass, Solar and Wind

#### 4.2.2.1 30 MMscfd Scenario

The Expansion Study considered that the 30 MMscfd gas supply can support operation of ten 17 MW Wartsila dual-fuel reciprocating engines. Based on K&M's heat and material balance calculations, 30 MMscfd of natural gas is only sufficient for operating 9 Wartsila engines. Therefore, the maximum capacity of the new gas-fired power plant is limited to 153 MW versus 170 MW considered in the Expansion Study.

Based on the Expansion Study, the new gas fired power plant capacity commence operation in 2023 with the addition of 102 MW (this includes two dual fuel engines with a total capacity of 34 MW installed prior to 2023 and initially operating on HFO). The new plant capacity then increases from 1029 MW to 153 MW. According to the Expansion Study, a new Hydro Project (165 MW) should be added in 2027. However, as demonstrated in Table 4.2 and Figure 4.5, the fact that the available quantity of natural gas limits the new gas fired power plant to 153 MW and system reserve margin of only 23 MW. This creates a firm capacity deficit of 15 MW by 2026 with the system reserve margin of only 23 MW. This margin is not only below 15% (38 MW) but is also below 2 times the size of the largest unit (34 MW). In order to overcome this deficit, the hydro power plant will have to be completed in 2026 instead of 2027 envisioned in the Expansion Study.

After addition of the new hydro power plant, the available firm capacity will be sufficient to cover the peak demand and reserve requirements for GPL and provide surplus firm capacity of 54 MW by 2035 (see Table 4.2).

**Table 4.2: Generation Expansion 30 MMscfd Scenario (Wartsila RICE Option)**

Type	Unit	2018	2019	2020	2021	2023	2024	2025	2026	2027	2035
HFO	MW	136.9	145.6	145.6	179.6	126.6	126.6	126.6	126.6	126.6	115.6
Solar	MW		6.0	6.0	6.0	6.0	6.0	6.0	6.0	6.0	6.0
Gas	MW		-	-	-	119.0	153.0	153.0	153.0	153.0	153.0
Wind	MW		10.3	10.3	10.3	10.3	10.3	10.3	10.3	10.3	10.3
Biomass	MW		-	-	13.8	13.8	13.8	13.8	13.8	13.8	13.8
Hydro	MW		-	-	-	-	-	-	-	165.0	165.0
Total Capacity	MW	137	162	162	210	276	310	310	310	475	464
<b>Total Firm Capacity</b>	<b>MW</b>	<b>137</b>	<b>146</b>	<b>146</b>	<b>180</b>	<b>246</b>	<b>280</b>	<b>280</b>	<b>280</b>	<b>445</b>	<b>434</b>
Maximum Demand	MW	117	121	125	129	154	194	224	256	291	330
System Reserve	MW	18	21	21	34	34	34	34	38	44	50
<b>Total Firm Capacity Required</b>	<b>MW</b>	<b>135</b>	<b>142</b>	<b>146</b>	<b>163</b>	<b>188</b>	<b>228</b>	<b>258</b>	<b>294</b>	<b>334</b>	<b>434</b>
<b>Surplus (Deficit)</b>	<b>MW</b>	<b>2</b>	<b>4</b>	<b>(0)</b>	<b>17</b>	<b>58</b>	<b>52</b>	<b>22</b>	<b>(15)</b>	<b>110</b>	<b>54</b>

**Figure 4.5: Capacity Forecasts. 2018 – 2035 (30 MMscfd Scenario, Wartsila RICE Option)**

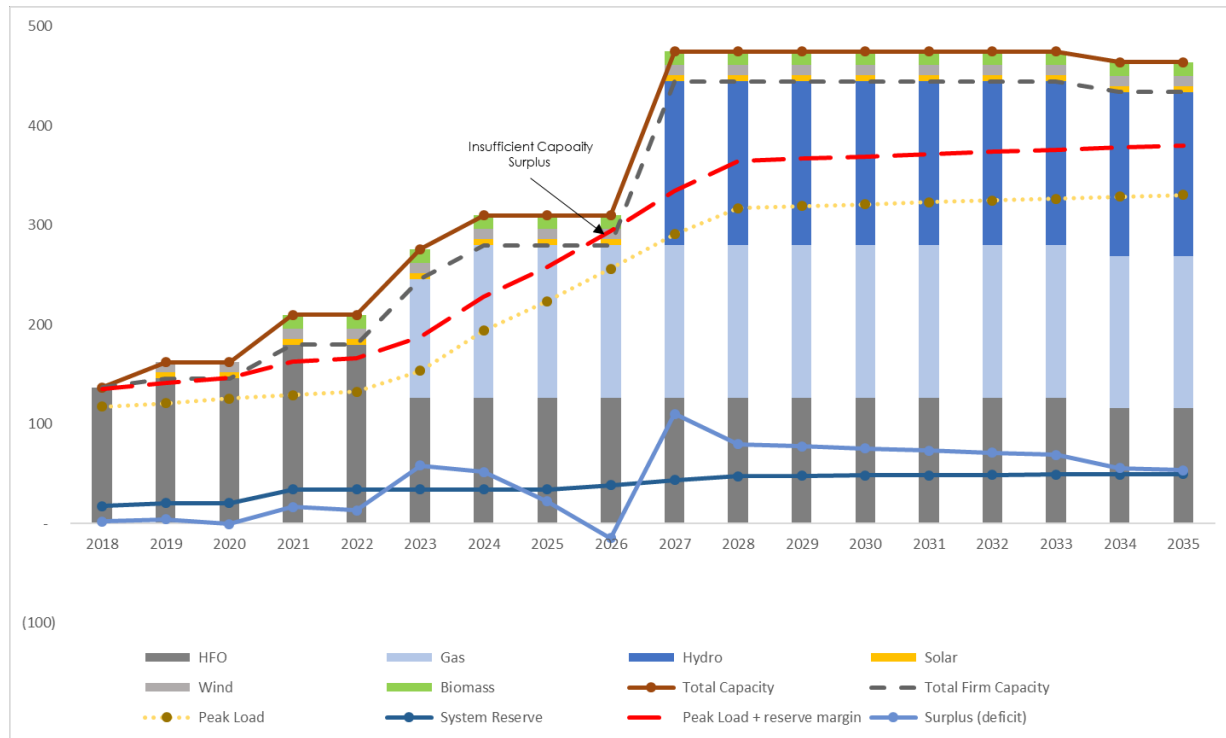

#### 4.2.2.2 50 MMscfd Scenario

The results of the demand and supply analysis for Wartsila 17 MW RICE option for 50 MMscfd scenario are presented in Table 4.3 and Figure 4.6. The capacity additions to the new plant are based on the Excel tables provided by the authors of the Expansion Study. The new plant will initially have a capacity of 102 MW including two dual fuel engines with a total capacity of 34 MW installed prior to 2023. The capacity will then gradually increase to 255 MW. As can be seen, there is sufficient firm generation capacity till 2035 to cover the peak load. Even though the firm capacity in 2035 is below the peak load plus 15% reserve margin by 9 MW, at 41 MW the reserve margin is still above 34 MW (2 times the capacity of the largest unit) and, therefore considered to be adequate. It is likely that GPL will be required to start adding new firm capacity in 2035 to cover increasing peak loads beyond 2035.

**Table 4.3: Generation Expansion 50 MMscfd Scenario (Wartsila RICE Option)**

Type		2018	2019	2020	2021	2023	2024	2025	2026	2027	2028	2035
HFO	MW	136.9	145.6	145.6	179.6	126.6	126.6	126.6	126.6	126.6	126.6	115.6
Solar	MW		6.0	24.0	24.0	24.0	24.0	24.0	24.0	24.0	24.0	24.0
Gas	MW		-	-	-	102.0	136.0	170.0	204.0	238.0	255.0	255.0
Wind	MW		10.3	10.3	40.3	40.3	40.3	40.3	40.3	40.3	40.3	40.3
Biomass	MW		-	-	23.8	23.8	23.8	23.8	23.8	23.8	23.8	23.8
Hydro	MW		-	-	-	-	-	-	-	-	-	-
Total Capacity	MW	137	162	180	268	317	351	385	419	453	470	459

Type		2018	2019	2020	2021	2023	2024	2025	2026	2027	2028	2035
<b>Total Firm Capacity</b>	<b>MW</b>	137	146	146	180	229	263	297	331	365	382	371
Maximum Demand	MW	117	121	125	129	154	194	224	256	291	317	330
Required System Reserve	MW	18	18	19	19	34	34	34	38	44	48	50
<b>Total Firm Capacity Required</b>	<b>MW</b>	<b>135</b>	<b>139</b>	<b>144</b>	<b>148</b>	<b>188</b>	<b>228</b>	<b>258</b>	<b>294</b>	<b>334</b>	<b>365</b>	<b>380</b>
<b>Surplus (Deficit)</b>	<b>MW</b>	<b>2</b>	<b>6</b>	<b>1</b>	<b>31</b>	<b>41</b>	<b>35</b>	<b>39</b>	<b>36</b>	<b>30</b>	<b>17</b>	<b>(9)</b>

**Figure 4.6: Capacity Forecasts. 2017 – 2035 (50 MMscfd Scenario, Wartsila RICE Option)**

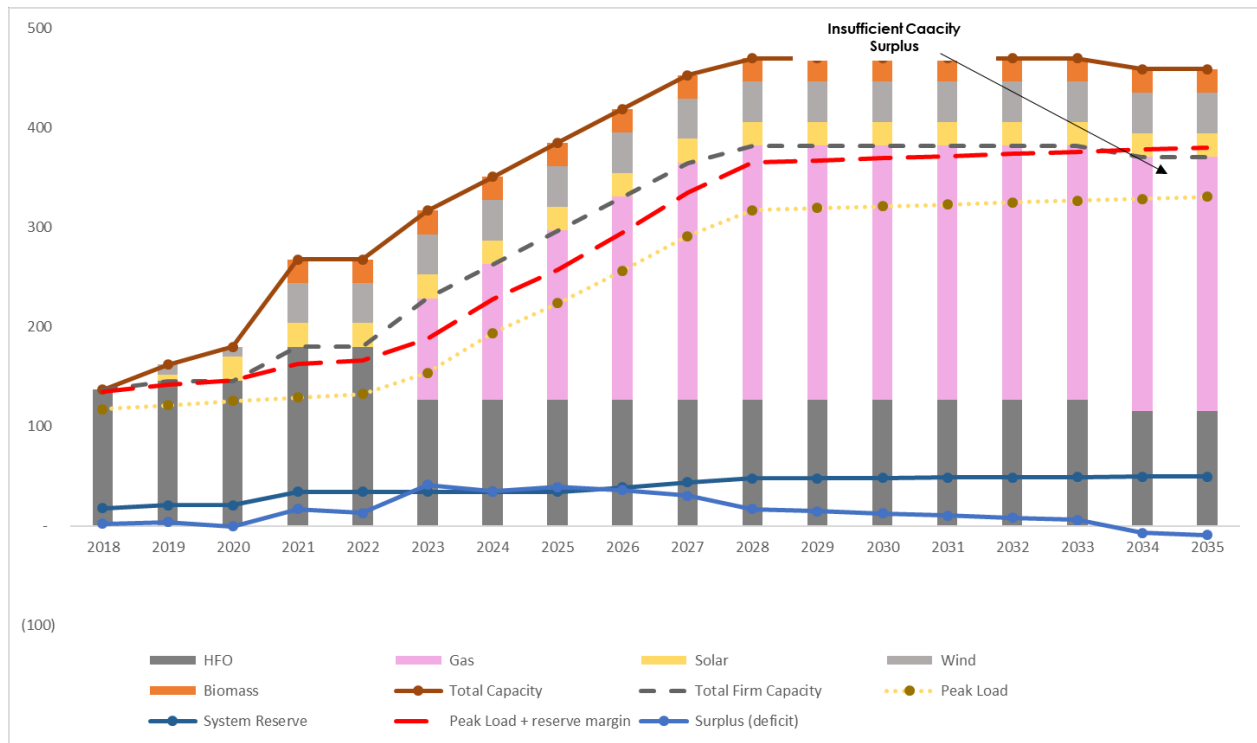

## 4.2.3 Demand and Supply Analysis for LM2500 Combine Cycle Technology Option

### 4.2.3.1 30 MMscfd Scenario

The results of the demand and supply analysis for GE LM2500 combined cycle option for 30 MMscfd scenario are presented in Table 4.4 and Figure 4.7. The new gas fired power plant capacity additions start in 2023 with addition of 120 MW (this includes two dual fuel engines with a total capacity of 34 MW installed prior to 2023 and initially operating on HFO). The new plant capacity then gradually increases from 120 MW to 180 MW. According to the Expansion Study, a new Hydro Project (165 MW) should be added in 2027. However, as demonstrated in Table 4.4 and Figure 4.7,



the system will experience firm capacity deficit of 9 MW by 2026, which would lead to the system available reserve margin being below the required target of 60 MW. Based on that, it seems that the hydro power plant will have to be completed in 2026 instead of 2027, as envisioned in the Expansion Study.

After additional of the new hydro power plant, the available firm capacity will be sufficient to cover the peak demand and reserve requirements for GPL and provide surplus firm capacity of 71MW by 2035 (see Table 4.4).

**Table 4.4: Generation Expansion 30 MMscfd Scenario (LM2500 CC Option)**

Type	Unit	2018	2019	2020	2021	2023	2024	2025	2026	2027	2028	2029	2030	2031	2032	2033	2034	2035
HFO	MW	136.9	145.6	145.6	179.6	127	127	127	127	127	127	127	127	127	127	127	116	116
Solar	MW		6	6	6	6	6	6	6	6	6	6	6	6	6	6	6	6
Gas	MW		-	-	-	120	150	180	180	180	180	180	180	180	180	180	180	180
Wind	MW		10	10	10	10	10	10	10	10	10	10	10	10	10	10	10	10
Biomass	MW		-	-	13.8	14	14	14	14	14	14	14	14	14	14	14	14	14
Hydro	MW		-	-	-	-	-	-	-	165	165	165	165	165	165	165	165	165
Total Capacity	MW	137	162	162	210	277	307	337	337	502	502	502	502	502	502	502	491	491
<b>Total Firm Capacity</b>	<b>MW</b>	<b>137</b>	<b>146</b>	<b>146</b>	<b>180</b>	<b>247</b>	<b>277</b>	<b>307</b>	<b>307</b>	<b>472</b>	<b>472</b>	<b>472</b>	<b>472</b>	<b>472</b>	<b>472</b>	<b>472</b>	<b>461</b>	<b>461</b>
Maximum Demand	MW	117	121	125	129	154	194	224	256	291	317	319	321	323	325	327	329	330
System Reserve	MW	18	21	21	34	60	60	60	60	60	60	60	60	60	60	60	60	60
<b>Total Firm Capacity Required</b>	<b>MW</b>	<b>135</b>	<b>142</b>	<b>146</b>	<b>163</b>	<b>214</b>	<b>254</b>	<b>284</b>	<b>316</b>	<b>351</b>	<b>377</b>	<b>379</b>	<b>381</b>	<b>383</b>	<b>385</b>	<b>387</b>	<b>389</b>	<b>390</b>
<b>Surplus (Deficit)</b>	<b>MW</b>	<b>2</b>	<b>4</b>	<b>(0)</b>	<b>17</b>	<b>33</b>	<b>23</b>	<b>23</b>	<b>(9)</b>	<b>121</b>	<b>94</b>	<b>92</b>	<b>91</b>	<b>89</b>	<b>87</b>	<b>85</b>	<b>72</b>	<b>70</b>

**Figure 4.7: Capacity Forecasts. 2018 – 2035 (30 MMscfd Scenario, LM2500 CC Option)**

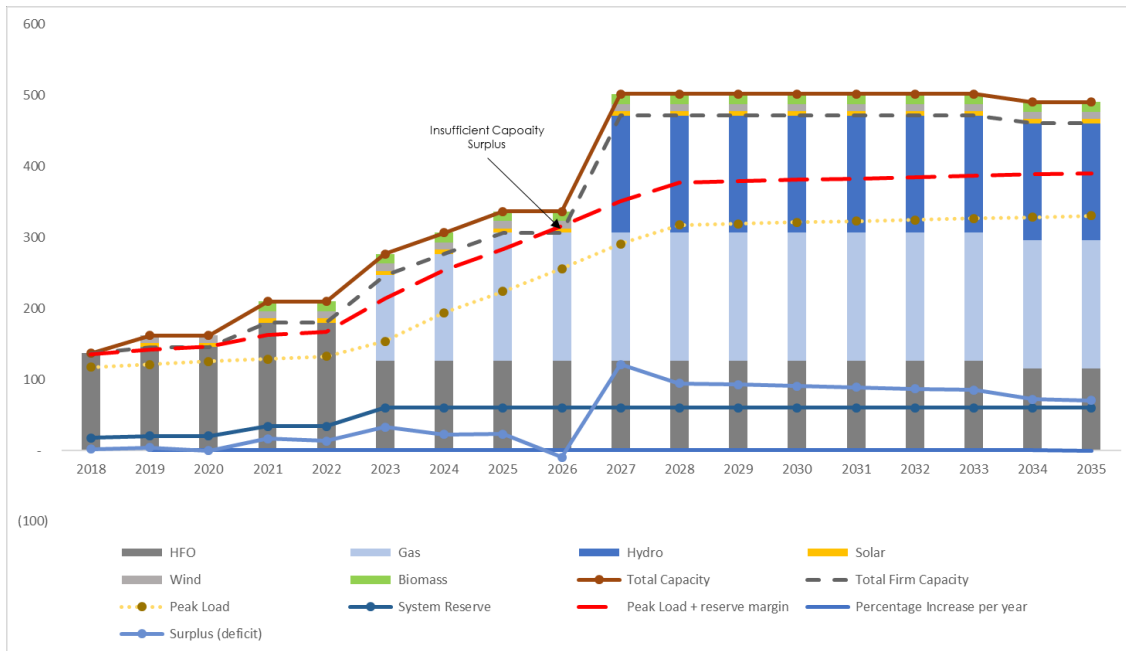

#### 4.2.3.2 50 MMscfd Scenario

The results of the demand and supply analysis for GE LM2500 combined cycle option for 50 MMscfd scenario are presented in Table 4.5 and Figure 4.8. As can be seen, there is sufficient firm generation capacity till 2035 to cover the peak load and provide adequate reserve margin. It is likely that GPL will be required to start adding new firm capacity in 2035 to cover increasing peak loads beyond 2035.

**Table 4.5: Generation Expansion 50 MMscfd Scenario (LM2500 CC Option)**

Type	Unit	2018	2019	2020	2021	2,023	2,024	2,025	2,026	2,027	2,028	2,029	2,030	2,031	2,032	2,033	2,034	2,035
HFO	MW	136.9	145.6	145.6	179.6	127	127	127	127	127	127	127	127	127	127	127	116	116
Solar	MW		6	24	24	24	24	24	24	24	24	24	24	24	24	24	24	24
Gas	MW		-	-	-	120	150	180	210	240	270	300	300	300	300	300	300	300
Wind	MW		10	10	40	40	40	40	40	40	40	40	40	40	40	40	40	40
Biomass	MW		-	-	24	24	24	24	24	24	24	24	24	24	24	24	24	24
Hydro	MW		-	-	-	-	-	-	-	-	-	-	-	-	-	-	-	-
Total Capacity	MW	137	162	180	268	335	365	395	425	455	485	515	515	515	515	515	504	504
<b>Total Firm Capacity</b>	<b>MW</b>	137	146	146	180	<b>247</b>	<b>277</b>	<b>307</b>	<b>337</b>	<b>367</b>	<b>397</b>	<b>427</b>	<b>427</b>	<b>427</b>	<b>427</b>	<b>427</b>	<b>416</b>	<b>416</b>
Maximum Demand	MW	117	121	125	129	154	194	224	256	291	317	319	321	323	325	327	329	330
System Reserve	MW	18	18	19	19	60	60	60	60	60	60	60	60	60	60	60	60	60
<b>Total Firm Capacity Required</b>	<b>MW</b>	<b>135</b>	<b>139</b>	<b>144</b>	<b>148</b>	<b>214</b>	<b>254</b>	<b>284</b>	<b>316</b>	<b>351</b>	<b>377</b>	<b>379</b>	<b>381</b>	<b>383</b>	<b>385</b>	<b>387</b>	<b>389</b>	<b>390</b>
<b>Surplus (Deficit)</b>	<b>MW</b>	<b>2</b>	<b>6</b>	<b>1</b>	<b>31</b>	<b>33</b>	<b>23</b>	<b>23</b>	<b>21</b>	<b>16</b>	<b>19</b>	<b>47</b>	<b>46</b>	<b>44</b>	<b>42</b>	<b>40</b>	<b>27</b>	<b>25</b>

**Figure 4.8: Capacity Forecasts. 2018 – 2035 (50 MMscfd Scenario, LM2500 CC Option)**

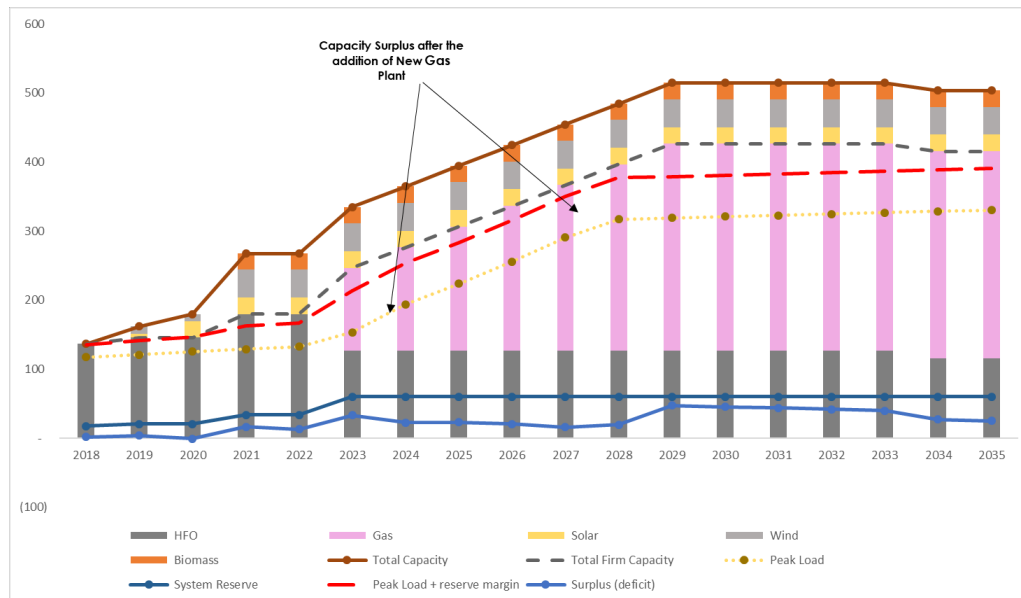

### 4.3 Analysis of Forecasted Generation from Different Sources

K&M selected years 2023 and 2035 and ran a dispatch estimate to forecast the dispatch of the new power plant and assess the split of total generated power between existing HFO power plants, new power plant, hydropower, biomass, solar, and wind. The analysis used the following assumptions:

- **Demand:** Annual load curves were projected by increasing the 2017 hourly demand by the forecasted increase in peak demands for the respective years.
- **Capacity of Power Plants:** The capacities of the power plants for the 30 MMscfd and the 50 MMscfd was based on the expansion plan provided in the Update to the Expansion Study using Wartsila RICE technology and corrected based on the K&M heat and material balance calculations. Based on K&M's calculations, 30 MMscfd of natural gas can only support total new natural gas power plant capacity of 153 MW and 50 MMscfd of natural gas can only support 255 MW of new natural gas plant capacity.

**Table 4.6: Power Plant Capacities (Based on the Expansion Study 30 MMscfd Gas Scenario), MW**

Type	2018	2019	2020	2021	2022	2023	2024	2025	2030	2035
HFO	137	146	146	180	180	127	127	127	127	116
Solar	-	6	6	6	6	6	6	6	6	6
Gas	-	-	-	-	-	119	153	153	153	153
Wind	-	10	10	10	10	10	10	10	10	10
Biomass	-	-	-	14	14	14	14	14	14	14

Type	2018	2019	2020	2021	2022	2023	2024	2025	2030	2035
Hydro	-	-	-	-	-	-	-	-	165	165
<b>Total Capacity</b>	<b>137</b>	<b>162</b>	<b>162</b>	<b>210</b>	<b>210</b>	<b>276</b>	<b>310</b>	<b>310</b>	<b>475</b>	<b>464</b>

**Table 4.7: Power Plant Capacities (Based on the Expansion Study 50 MMscfd Gas Scenario)**

All Units are in MW	2018	2019	2020	2021	2022	2023	2024	2025	2030	2035
HFO	137	146	146	180	180	127	127	127	127	116
Solar	-	6	24	24	24	24	24	24	24	24
Gas*	-	-	-	-	-	102	136	170	255	255
Wind	-	10	10	40	40	40	40	40	40	40
Biomass	-	-	-	24	24	24	24	24	24	24
<b>Total Capacity</b>	<b>137</b>	<b>162</b>	<b>180</b>	<b>268</b>	<b>268</b>	<b>317</b>	<b>351</b>	<b>385</b>	<b>470</b>	<b>459</b>

- Capacity Factors and Dispatch Assumptions:** The capacity factors for Hydropower was based on the Expansion Study and biomass were assumed at 60%. The new power plant availability was assumed at 92%. The wind and solar dispatches were projected for each hour using NREL's (National Renewable Energy Laboratory) SAM (System Advisor Model) software. The dispatch assumes that renewables (wind, solar, and biomass) are dispatched first, hydropower is dispatched next, followed by the new gas plant, and HFO is used to dispatch against whatever demand is left.

### 4.3.1 Electricity Demand Analysis – 2023

2023 was selected in our analysis as this is the year new gas plant is expected to start its operations. The capacity of the new gas fired plant used for this analysis is 119 MW for the 30 MMscfd and 102 MW for the 50 MMscfd scenario.

During the kickoff mission, it was mentioned that GPL is considering installing an increased amount of PV Solar in the future. K&M's analysis estimated the impact of additional PV solar generation on the system by running the analysis on three PV Solar penetration scenarios; 6 MW for 30 MMscfd and 24 MW for 50 MMscfd based on expansion plan), 30 MW, and 60 MW (assumed for higher PV Solar penetration).

#### 4.3.1.1 30 MMscfd Gas Supply

Figures below show the load duration curves and generation structure for the three PV Solar penetration scenarios for the 30 MMscfd gas supply scenario.

**Figure 4.9: Load Duration Curve, 6MW Solar – 2023 (30 MMscfd)**

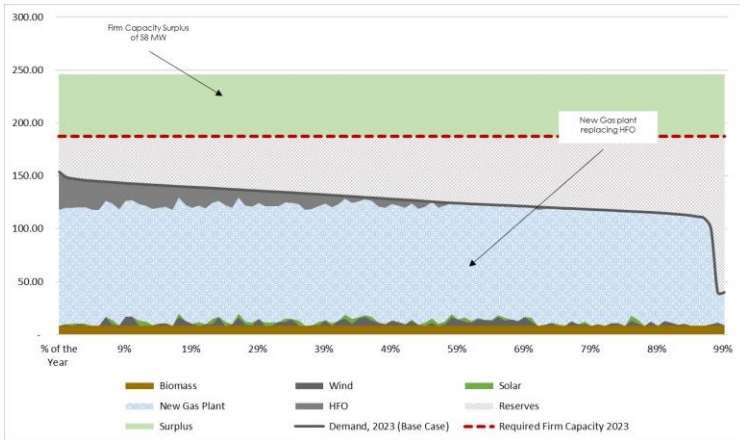

**Figure 4.10: Load Duration Curve, 30 MW Solar – 2023 (30 MMscfd)**

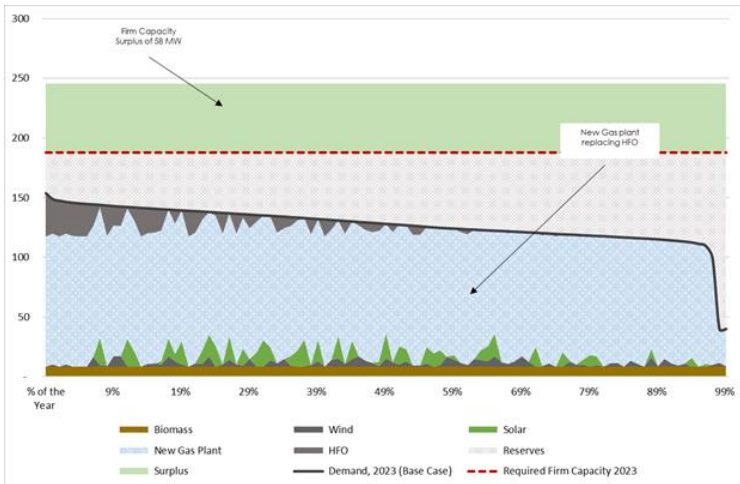

**Figure 4.11: Load Duration Curve, 60 MW Solar - 2023 (30 MMscfd)**

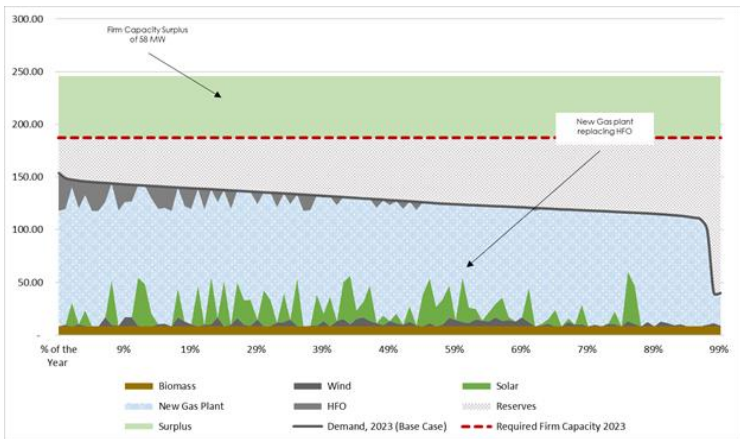

**Figure 4.12: Generation Structure, 6 MW Solar – 2023 (30 MMscfd)**

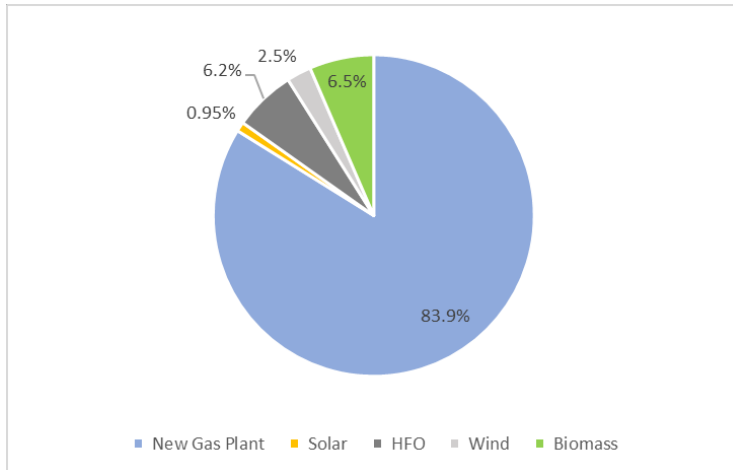

**Figure 4.13: Generation Structure, 30 MW Solar - 2023 (30 MMscfd)**

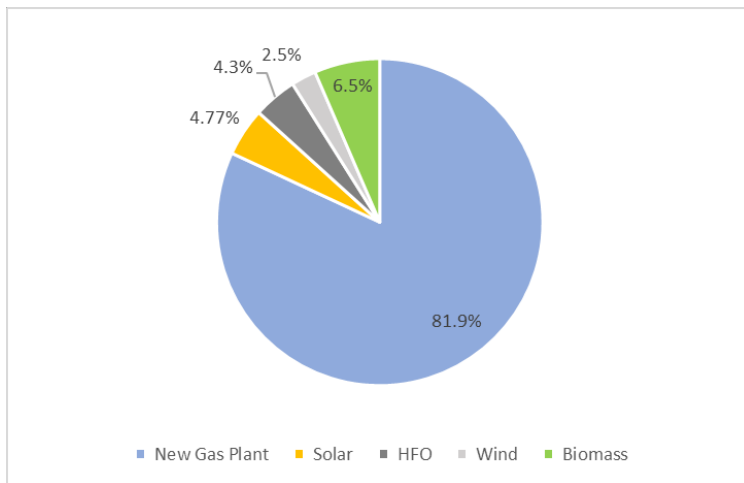

**Figure 4.14: Generation Structure, 60 MW Solar – 2023 (30 MMscfd)**

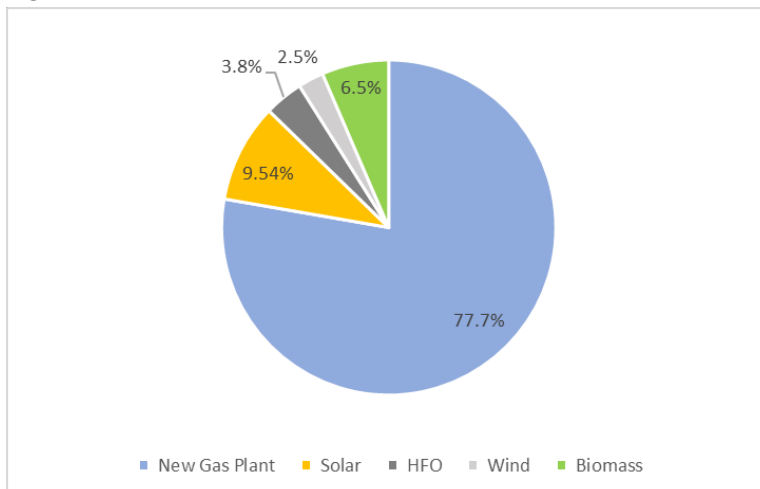



As seen in the figures above, by 2023 the new gas plant will provide approximately 84% of the total generation for the year and dramatically reduce Guyana and GPL's reliance on imported HFO.

#### 4.3.1.2 50 MMscfd Gas Supply

Figures below show the load duration curves for the three PV Solar Penetration scenarios for the 50 MMscfd gas supply.

**Figure 4.15: Load Duration Curve, 24 MW Solar – 2023 (50 MMscfd)**

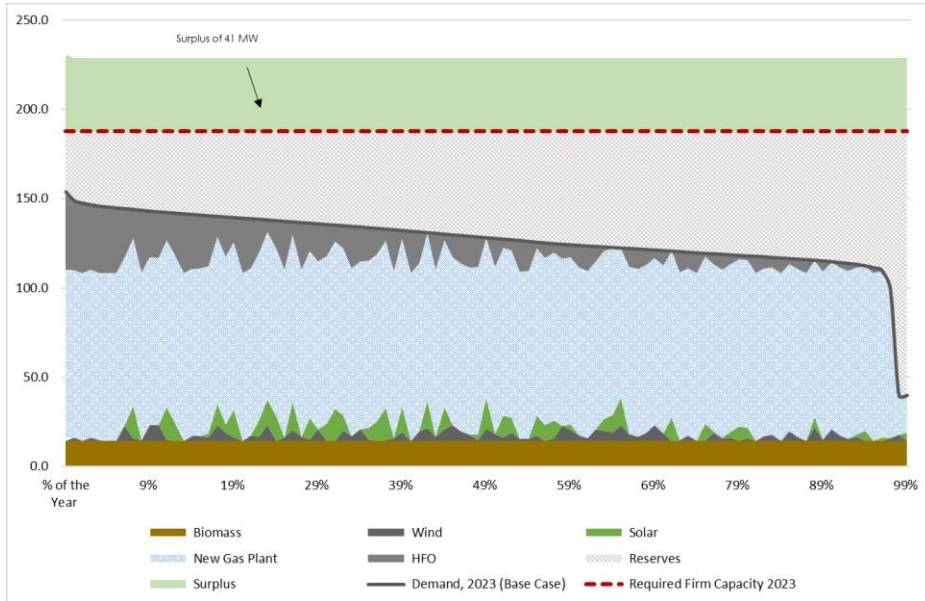

**Figure 4.16: Load Duration Curve, 30 MW Solar - 2023 (50 MMscfd)**

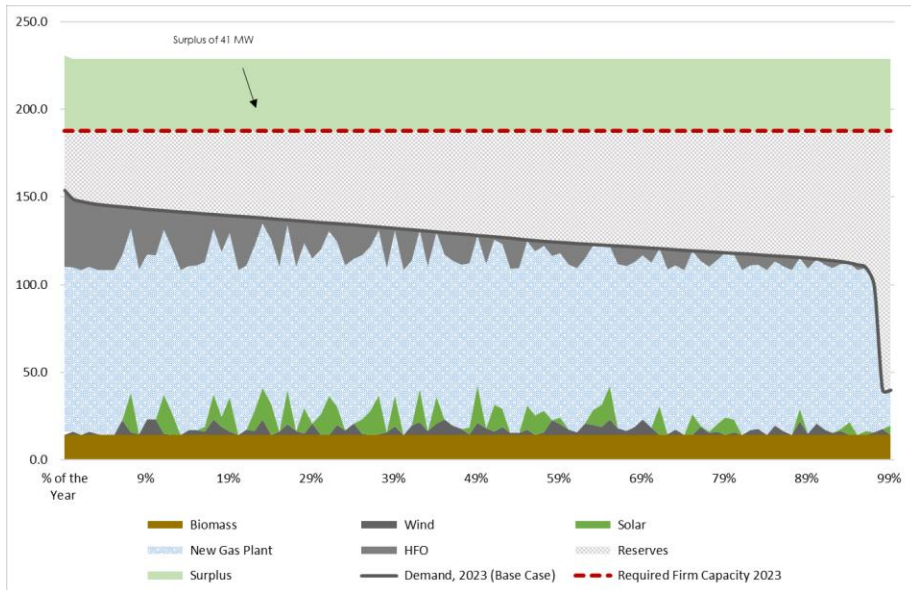

**Figure 4.17: Load Duration Curve, 60 MW Solar – 2023, (50 MMscfd)**

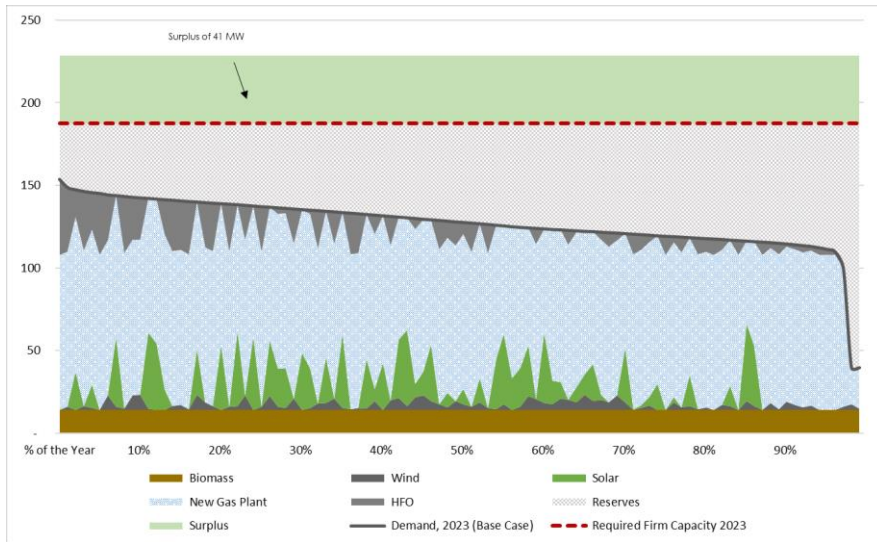

**Figure 4.18: Generation Structure, 24 MW Solar – 2023 (50 MMscfd)**

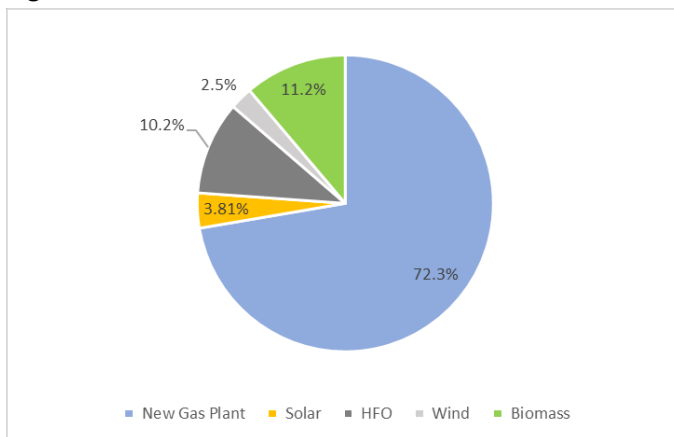

**Figure 4.19: Generation Structure, 30 MW Solar - 2023 (50 MMscfd)**

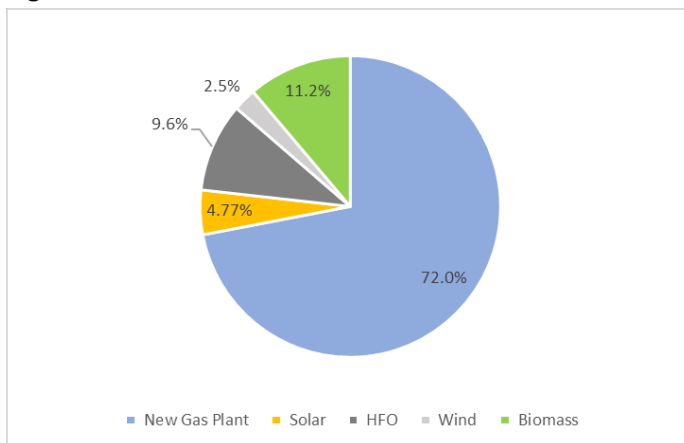

**Figure 4.20: Generation Structure, 60 MW Solar – 2023 (50 MMscfd)**

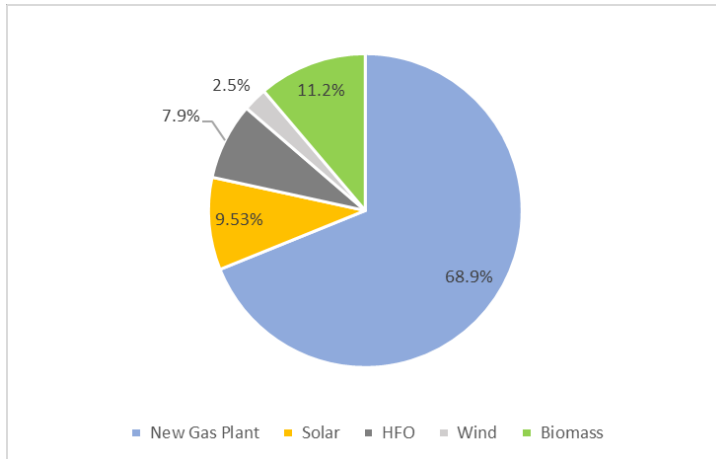

Like for the 30 MMscfd gas supply scenario, for a 50 MMscfd scenario the new gas plant will provide the majority (73%) of the total electricity demand of Guyana and significantly reduce the dependence of Guyana on imported fuel oil. Increase of solar penetration to 60 MW will reduce generation from HFO sources by 5% but will also reduce generation by the new gas fired power plant by about 3.5%.

### 4.3.2 Electricity Demand Analysis – 2035

2035 was selected in our analysis as this is the last year in the forecast provided by the Expansion Study. K&M performed analysis for 30 MMscfd and 50 MMscfd scenarios.

#### 4.3.2.1 30 MMscfd Gas Supply

Like the previous section, K&M's analysis estimated the impact for three PV Solar penetration scenarios; 6 MW, 30 MW, and 60 MW.

**Figure 4.21: Load Duration Curve, Solar 6 MW – 2035 (30 MMscfd)**

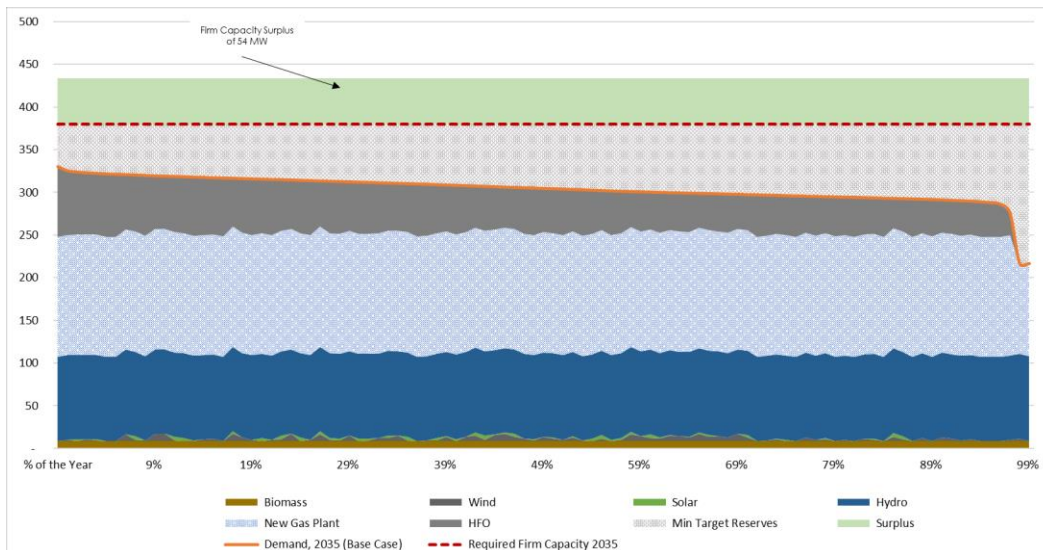

**Figure 4.22: Load Duration Curve, Solar 30 MW - 2035 (30 MMscfd)**

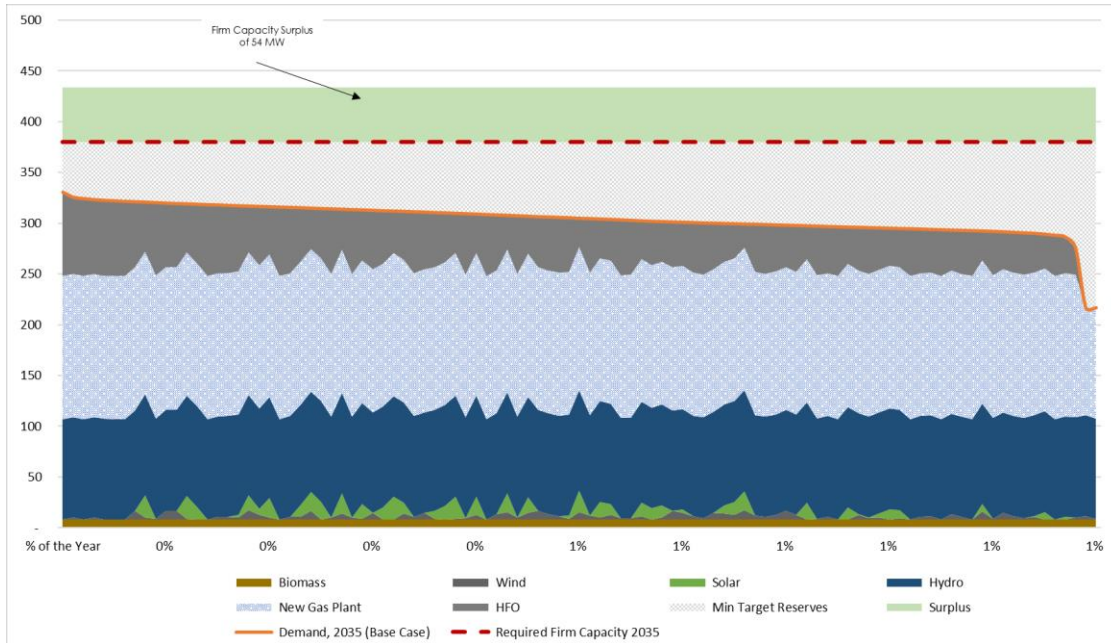

**Figure 4.23: Load Duration Curve, Solar 60 MW – 2035 (30 MMscfd)**

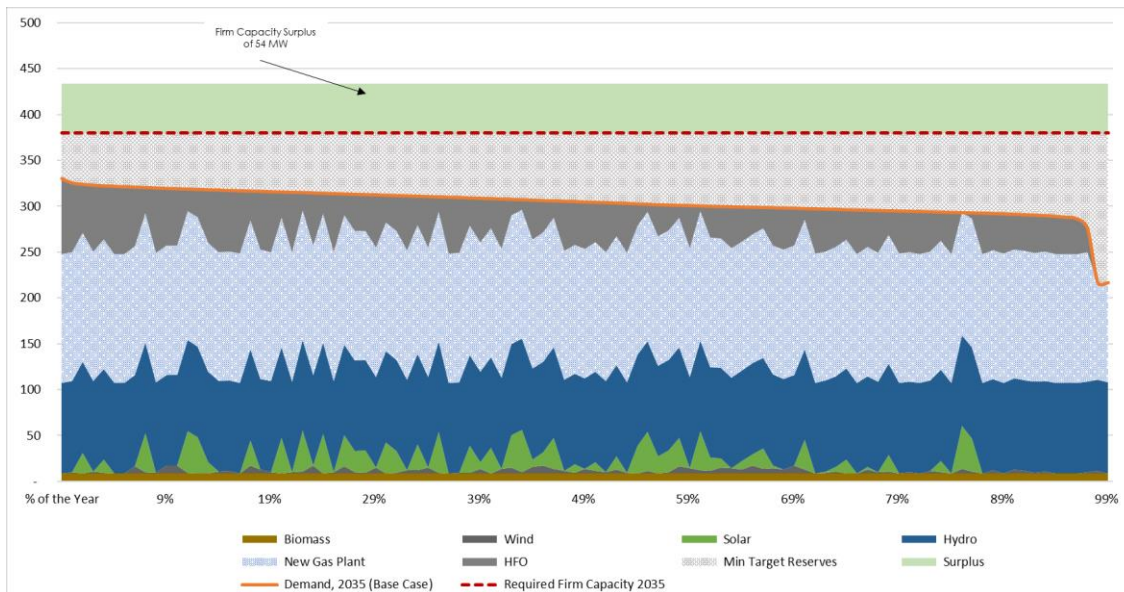

**Figure 4.24: Generation Structure, 6 MW Solar – 2035 (30 MMscfd)**

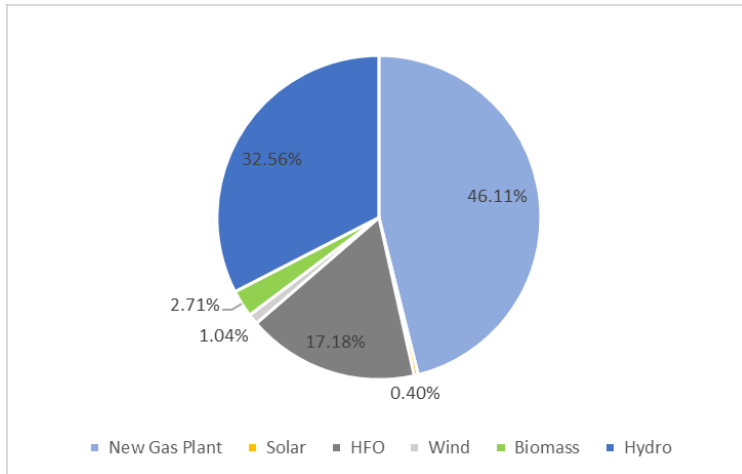

**Figure 4.25: Generation Structure, 30 MW Solar - 2035 (30 MMscfd)**

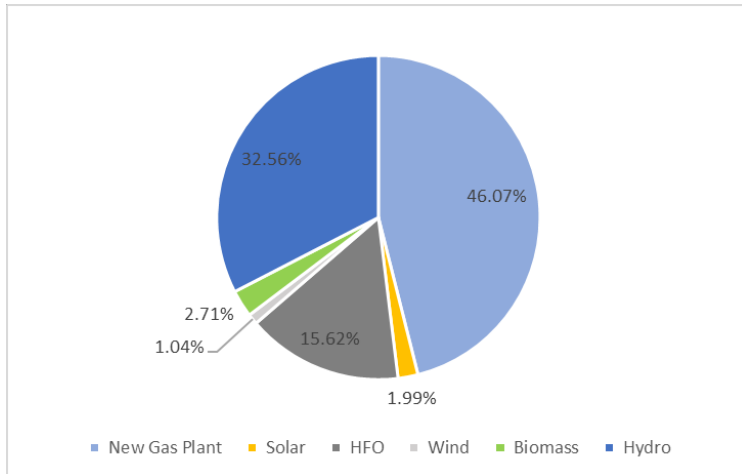

**Figure 4.26: Generation Structure, 60 MW Solar – 2035 (30 MMscfd)**

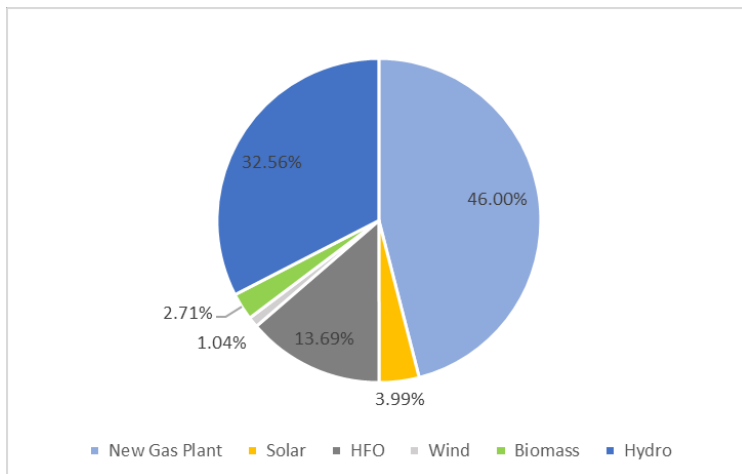



As the above figures show, by 2035 Guyana will have adequate capacity to meet its peak demand plus required reserve capacity and have a firm capacity surplus of 54 MW after the addition of 153 MW gas plant and 165 MW Hydropower plant. The addition of hydropower will reduce the share of power generated from the new gas power plant to approximately 46% of the total system generation, this provides Guyana with diversity in firm generating options and reduces the dependence of the electrical system on a single source. Hydropower and Gas work together to form Guyana's baseload generation in 2035 providing 79% of the total power generated. The flexibility of gas generation can also provide buffer in case of seasonal variation in hydropower.

Increase of solar penetration to 60 MW would reduce generation by HFO sources and will have minor impact on generation by the new gas fired power plant.

#### 4.3.2.2 50 MMscfd Gas Supply

The load duration curves for different PV Solar penetration scenarios is presented below:

**Figure 4.27: Load Duration Curve, Solar 24 MW – 2035 (50 MMscfd)**

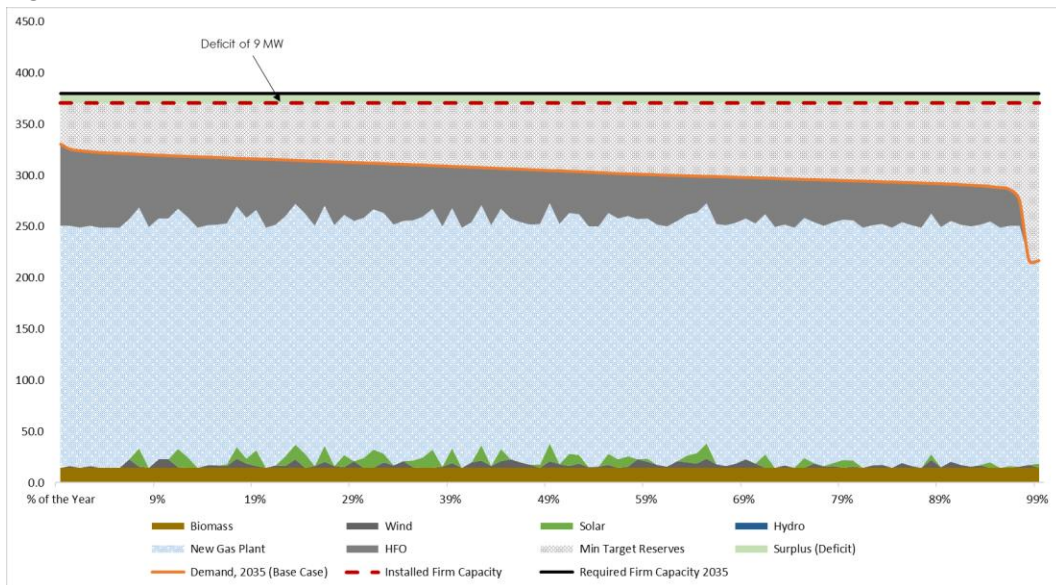

**Figure 4.28: Load Duration Curve, Solar 30 MW - 2035 (50 MMscfd)**

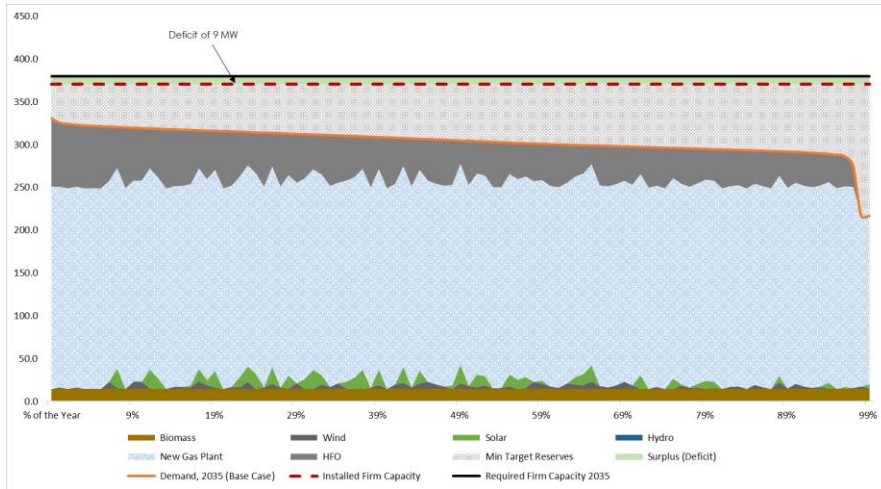

**Figure 4.29: Load Duration Curve, Solar 60 MW – 2035 (50 MMscfd)**

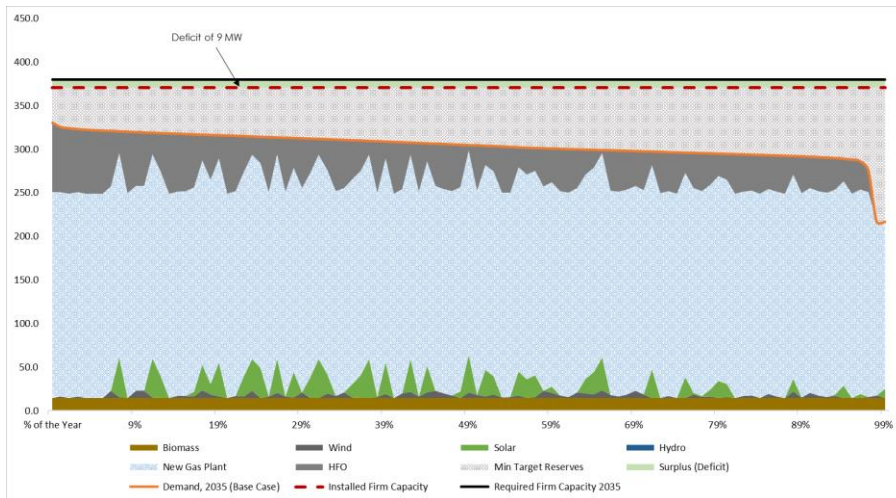

**Figure 4.30: Generation Structure, 24 MW Solar – 2035 (50 MMscfd)**

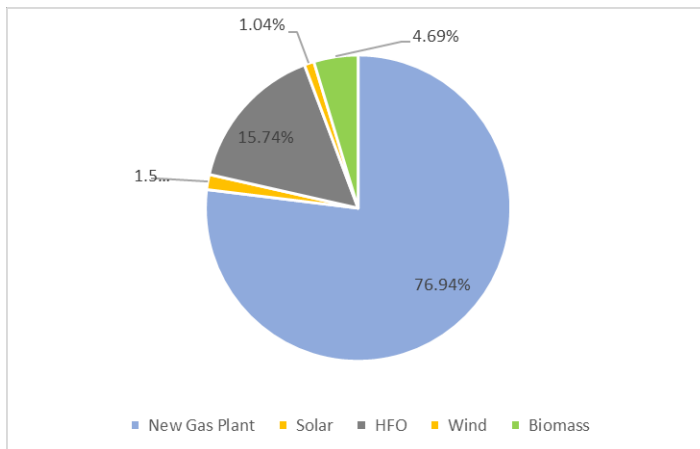

**Figure 4.31: Generation Structure, 30 MW Solar - 2035 (50 MMscfd)**

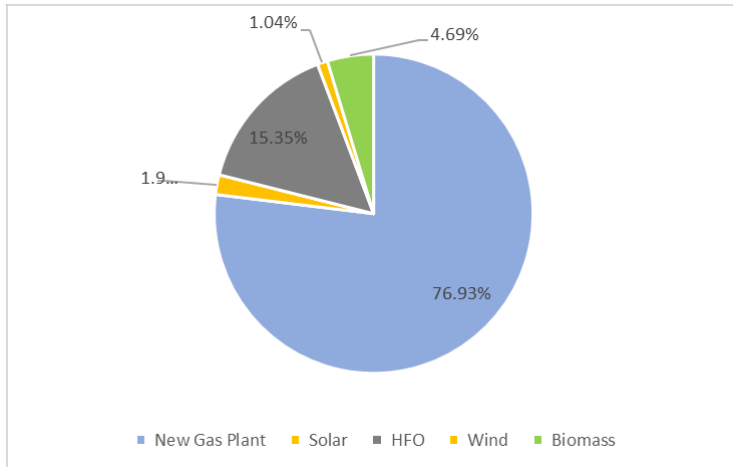

**Figure 4.32: Generation Structure, 60 MW Solar – 2035 (50 MMscfd)**

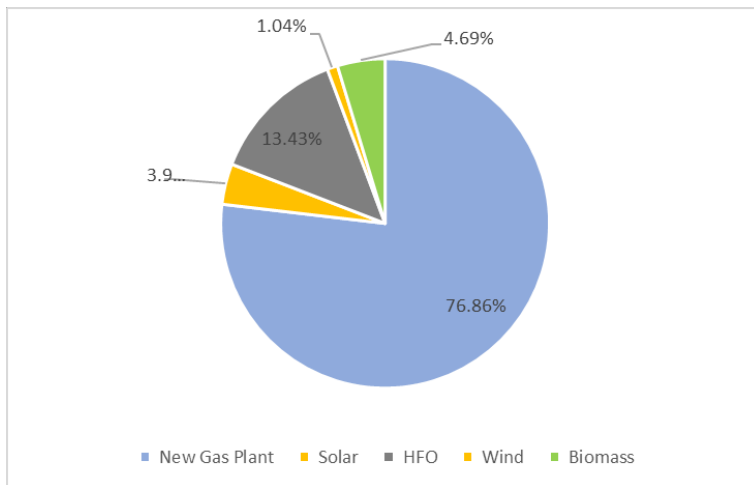

As can be seen from the above, the Guyanese electric system will have enough capacity to meet its peak demand, but the available reserve margin at 41 MW will be slightly below the target of 15%. At the same time, it will still be above 34 MW (two times that capacity of the largest unit) and could be considered to be adequate. Still, K&M considers that GPL would need to add additional capacity in 2035 to cover future demand increase. Also, there is a risk of overreliance on Natural Gas as the primary source of electricity as the new power plant will provide 77% of the total power demand in Guyana. Any disruption in Natural Gas supply will require burning significantly more expensive backup fuel, which would substantially increase the cost of electricity generation to GPL. This risk could be significantly reduced in case of implementation of the Arco Norte transmission interconnection project connecting Guyana, Northern Brazil, Suriname, and French Guyana.

Increase in PV solar penetration will have minor impact on the new gas fired power plant generation.



## 5 Gas Supply and Demand Analysis

### 5.1 Natural Gas Supply

According to the information provided in the Expansion Study, ExxonMobil through their subsidiary, Esso Exploration and Production Guyana Limited (EEGPL) is developing the Stabroek oil field block located approximately 190 km offshore Guyana. Oil will be produced using the Floating Production, Storage and Offloading (FPSO) facility and will be accompanied by Natural Gas production. Part of Natural Gas will be used to support the power requirements at the FPSO and for field reinjection to optimize oil production. The remaining Natural Gas will be made available from 2023 as an indigenous fuels source power generation in Guyana. Raw Natural Gas from the FPSO would be delivered onshore via an underwater pipeline and treated to remove LPG from the gas stream at a gas treatment plant. Treated gas would then be supplied for power generation.

**Figure 5.1: Stabroek Oil Field Block Development**

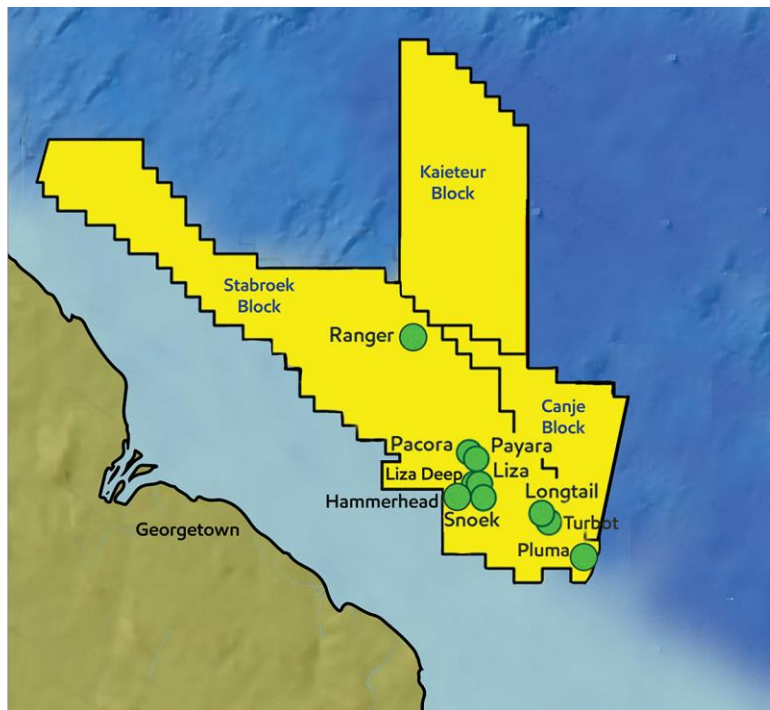

Source: Exxon Mobil

According to Exxon Mobil, the latest estimates for gross recoverable resources at the Stabroek Block are more than 6 billion recoverable oil-equivalent barrels. The Lisa Phase 1 production project currently underway will tap into approximately 450 billion barrels, which is about 11% of the total estimated recoverable reserves. There are a total of 10 well discoveries announced to date by Exxon Mobil in the Stabroek block. Pluma-1 well is ExxonMobil's tenth and latest discovery to date, which was announced in December 2018.

According to the Expansion Study, the part of Natural Gas reserves that can be allocated for power generation from Lisa-1 production project are estimated at 0.2 Tcf (trillion cubic feet). K&M could not independently verify this information but assumes that this is based on the information provided by Exxon Mobil. Since Lisa-1 represents only 11% of the total recoverable oil resources, it would be logical to assume that the total Natural Gas reserves in the Stabroek block are proportionately higher and could be estimated at 1.78 Tcf. The most recent development in the Stabroek reserves exploration includes approval of the Liza-2 production project. It should be noted that Liza-2 production project is not expected to provide incremental increase in available quantities of natural gas to the quantities factored in the Liza-1 project.

### **5.1.1 Natural Gas Demand**

Based on the information provided in both the Desk Study of the Options, Cost, Economics, Impacts, and Key Considerations of Transporting and Utilizing Natural Gas from Offshore Guyana for Generation of Electricity prepared by Energy Narrative in June 2017 (further referred to as a Desk Study) and the Expansion Study, the Natural Gas quantities that can be made available for power generation in Guyana from Lisa-1 production project could range between 30 MMscfd and 145 MMscfd.

The Expansion Study based their analysis on two gas supply scenarios: 30 MMscfd and 50 MMscfd. It should be noted that both the Expansion Study and the Desk Study considered that the 30 MMscfd Natural Gas quantity refers to raw untreated gas supplied from the FPSO and that only 26.3 MMscfd of treated Natural Gas would be available for power generation. According to the response provided by Exxon Mobil in response to question by K&M via an E-mail dated September 14, 2018, the 30 MMscfd gas quantity is the quantity of treated Natural Gas that will be made available for power generation and the quantity of raw gas supplied from FPSO to the treatment plant would be 3 to 4 MMscfd higher. Therefore, the quantities of untreated Natural Gas that will be provided from the FPSO for power generation would be approximately 34 MMscfd – to supply 30 MMscfd of treated gas and 55 MMscfd – to supply 50 MMscfd of treated gas.

Assuming that useful life of the new power plants is 30 years, the total quantity of Natural Gas required for power generation over the 30-year period would be 0.37 Tcf for 30 MMscfd and 0.6 Tcf for 50 MMscfd cases.

Comparing these values to the total Natural Gas reserves of 1.78 Tcf estimated above, it can be concluded that the total estimated reserves significantly exceed the total estimated demand. Even if Natural Gas is not produced on each oil reservoir, it is likely that there will be sufficient Natural Gas reserves to support Guyana's gas fired power generation for the foreseeable future.

#### **5.1.1.1 Range of Capacities Supported by Projected Natural Gas Quantities**

Based on K&M's estimate performed in Section 7 of this report, 30 MMscfd gas supply can support the addition of 108 MW to 180 MW of new gas capacity and 50 MMscfd gas supply can support the addition of 194 MW to 300 MW of new gas capacity (depending on the selected power generation technology). According to the electricity demand analysis in Section 4, the additional firm capacity required by year 2035 to cover peak capacity plus reserve margin is approximately 250 MW. Therefore, new gas capacity based on 30 MMscfd gas supply is not sufficient to cover the forecasted electricity demand growth while gas capacity based on 50 MMscfd would fulfill the required firm generation capacity by 2035.

### 5.1.1.2 Natural Gas Demand Variability

The amount of Natural Gas required by a Power Plant is a function of the power plant load at any given moment and variations in the load can cause fluctuations in gas demand. Exxon Mobil in their E-mail dated September 14, 2018 confirmed that their supply facilities can tolerate changes in the gas demand associated with the power plant load by reinjecting unused gas into the reservoir.

### 5.1.2 Natural Gas Properties

The expected raw and treated Natural Gas compositions are presented in Table 5.1 and Natural Gas heating values in Table 5.2. The raw gas molar fractions are based on the data presented in the Desk Study. The weight fraction and composition of the treated gas are calculated by K&M based on the raw gas properties.

**Table 5.1: Natural Gas Composition**

Natural Gas Composition	Raw Gas				Treated Gas		
	Molar Fraction, %	Molecular Weight kg/mole	Weight per mole of Natural Gas, kg/mole	Weight Fraction, %	Molar Fraction %	Weight per mole of Natural Gas, kg/mole	Weight per mole of Natural Gas, kg/mole
Methane	79.1%	16	12.656	58.0%	91.1%	14.6	85%
Ethane	7.3%	30	2.19	10.0%	8.4%	2.5	15%
Propane	6.7%	44	2.948	13.5%			
i-Butane	1.0%	58	0.58	2.7%			
n-Butane	2.8%	58	1.624	7.4%			
Condensate (C5+)	1.9%	72	1.368	6.3%			
Water	0.0%	18	0	0.0%			
CO2	0.8%	44	0.352	1.6%			
H2S	0.0%	34	0	0.0%			
Nitrogen	0.4%	28	0.112	0.5%	0.5%	0.1	1%
Total	100%		21.83	100.0%	100.0%	17.2	100%

Source: Desk Study of the Options, Cost, Economics, Impacts, and Key Considerations of Transporting and Utilizing Natural Gas from Offshore Guyana for Generation of Electricity. Energy Narrative. June 2017

**Table 5.2: Natural Gas Heating Values**

Source	Raw Gas, HHV, Btu/scf	Raw Gas, LHV, Btu/scf	Treated Gas, HHV Btu/scf	Treated Gas, LHV Btu/scf
Desk Study	1302	1173	1169	1053
Exxon Mobil	1270	1144	1100	991

The heating values provided by two sources above are reasonably close. For the purposes of calculating heat and material balances in this report K&M used the values of treated natural gas provided by Exxon Mobil.

Exxon Mobil indicated that gas heating value and other property may vary over time and that it is even possible that the power plant would be receiving raw untreated gas containing large quantities of higher hydrocarbons such as propane, butane, and gas condensate during the gas treatment system outages. Typically, gas turbines and gas fired reciprocating engines are designed for a fairly narrow range of Natural Gas properties, and although it is likely that variations in heating value of treated gas can be tolerated, the ability to design gas turbines and reciprocating engines to accept both treated and untreated Natural Gas is doubtful. K&M recommends MPI discusses with Exxon Mobil the possibility of providing redundancy for the gas treatment plant. As an example, the gas treatment plant can have two 100% capacity treatment trains and ensure uninterrupted supply of treated Natural Gas to the power plant.

## 6 Viability of Conversion of Guyana's Existing Oil-Fired Power Plants to Natural Gas or Dual Fuel Operation

---

K&M assessed the viability of converting the existing liquid-fuel based reciprocating engines to dual-fuel reciprocating engines capable of using both HFO and Natural Gas as a fuel source. The older power plants in the DBIS system were not considered in our assessment given that they are nearer to the end of their operating lives and the high cost of conversion. The two newest power plants – Vreed-en-Hoop power station and the Kingston 2 power station could be considered as candidates for potential conversion to dual-fuel operation as they have sufficient remaining operating lives.

The Vreed-en-Hoop power station currently consists of three 8.7 MW units commissioned in 2014. The Kingston 2 power station currently consists of three 6.9 MW commissioned in 2009 and two 7.8 MW units commissioned in 2011. All the units at these two plants are Wartsila liquid-fuel reciprocating engines and the conversion to dual-fuel units would be completed by Wartsila. Wartsila estimates that the cost to convert the engines to dual-fuel would be \$355/kW and it would cost US\$9.2 million and US\$12.9 Million to convert the units at the Vreed-en-Hoop power station and the Kingston 2 power station respectively. Additionally, the cost of gas pipeline between the landing point and the existing power plants will be high and, depending on the distance, could be between US\$25 and US\$50 million, so that the total conversion cost could be over \$1000/kW. The conversion cost of these units is comparable to the cost of new dual-fuel units, and without taking considering other factors, based purely on the economics of conversion, constructing a new dual fuel plant is be a better option.

Additionally, bringing Natural Gas to the sites of the existing plants appears to be difficult and expensive. Gas pipelines would, i) need to be routed through heavily developed and populated areas to reach the sites, ii) securing right-of-way for the pipelines will be a significant issue, iii) routing a high-pressure gas pipeline through populated areas is highly undesirable from a safety standpoint, and iv) the capital cost of constructing a pipeline to the plants is prohibitively high because of the large distances between the landing point of the off-shore gas pipeline and the sites.

Based on the high cost of conversion and the difficulty of bringing Natural Gas to the existing power plants, conversion of existing power plants to dual fuel (HFO and Natural Gas) operation is not a viable option and therefore not recommended.

## 7 New Power Plant Site, Size and Technology Options Analysis

---

### 7.1 New Power Plant Site

The study assumes that the new power plant will be constructed at a generic site located not too far from Georgetown, the major load center. Based on other experiences and considering that the gas will be transported to shore via a pipeline, it is likely that the selected site will be located close to the coast, and since Guyana coast is vulnerable to sea rise effects, shore protection will be required on at least three sides of the plant boundary meaning, the 2 lateral side and the side facing the sea. For the purposes of this study it is assumed that the gas-processing facility will provide their own shore protection system. The site preparation assumptions address climate resilience issues and include a more robust protection from high tide due to possible rise in the sea level.

Considering the characteristics of the coastal areas of Guyana it is possible that the offshore waters at the site could stay shallow for a long distance. For the conceptual design purposes K&M assumes that a new barge-unloading facility will be installed adjacent to the site so that equipment and materials required for power plant construction and operation would be shipped to Georgetown and off-loaded onto shallow-draft barges for delivery to the site.

The total area required for the power plant site is estimated at between 20 and 25 acres.

### 7.2 Plant Size Considerations

The size (capacity) of the new gas fired power plant should be selected based on the following considerations:

- System capacity requirements
- Available quantities of Natural Gas
- Heat rate of the plant
- Plant dispatch and resulting total cost of electricity to GPL.

K&M will select the optimal plant capacity using a two-step approach.

- During the first step K&M will evaluate the total new firm capacity that needs to be installed in the DBIS system to cover peak loads projected in the Expansion Study versus maximum capacity that can be generated from the quantities of Natural Gas that can be made available for the project and use the results of this evaluation for technology option analysis. This step is presented in this section of the Final Report.
- During the second step we will optimize the plant size and approach to plant capacity increase over time for the two best technology options selected. This step is presented in Section 11 of this Final Report.

K&M estimated the required new firm capacity based on the demand growth forecast presented in the Expansion Study. The required firm capacity is calculated by taking the maximum projected peak load and increasing it by 15% reserve margin target used in the Expansion Study or two times the size of the largest unit, whichever is higher. The minimum additional firm capacity is calculated by subtracting the existing installed capacity of HFO-fired reciprocating engine power plants from

the target firm capacity (including the reserve margin). The required capacity calculations start from 2023, the expected year of beginning of operation of new gas fired power plant.

K&M understands that the target reserve margin of 15% is assumed in the Expansion Study in part based on the plans of creating an Arco Norte interconnected system connecting the power systems of Guyana, Suriname, Brazil, and French Guiana and agrees that this target for reserve margin is appropriate for an interconnected system. Such margins are typical and are used by several regional system operators in the U.S. (see Figure 7.1 below).

**Figure 7.1: Target Reserve Margins for U.S. Regions**

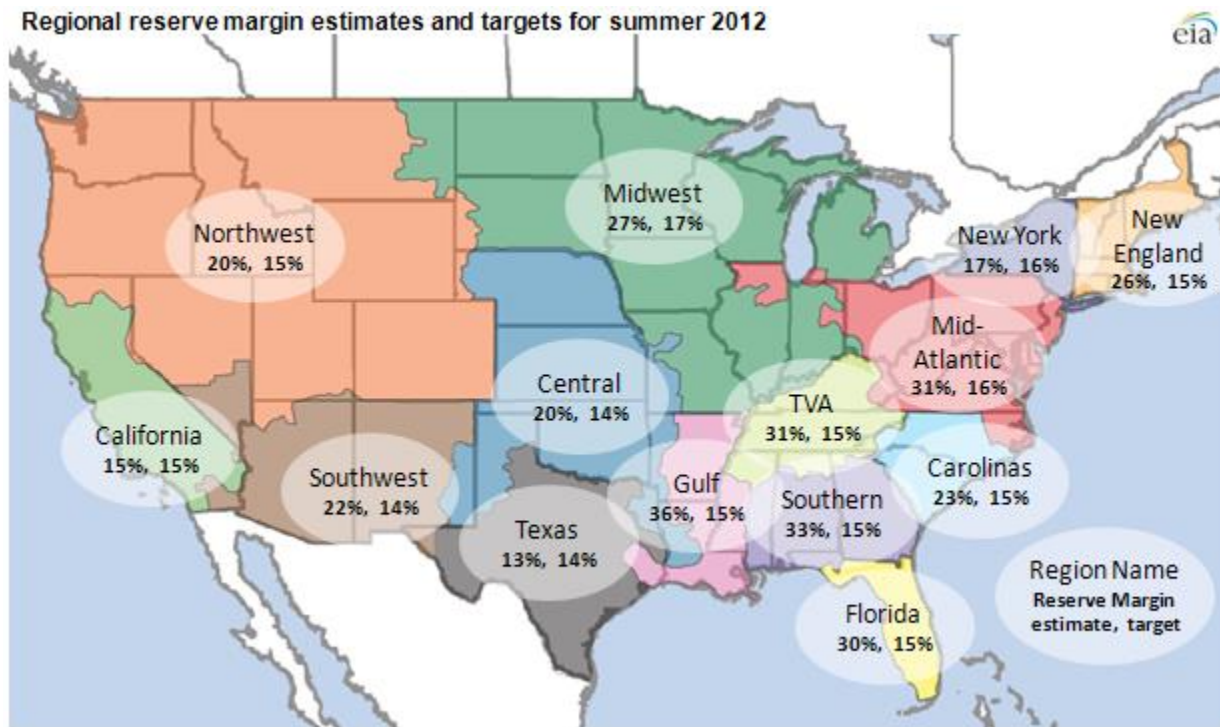

Source: U.S. Energy Information Administration (<https://www.eia.gov/todayinenergy/detail.php?id=6510#>).

GPL is currently using the deterministic method of establishing the reserve margin at 2 times the capacity of the largest unit. This method is used by several utilities around the world, especially for relatively small and isolated island utilities. The method of setting the required reserve margin at 2 times the capacity of the largest unit is based on a requirement that the system can cover the peak load in a situation when one of the largest units experiences a forced outage and another largest unit has a maintenance outage. Information on reserve margins of some tropical island utilities with a peak load comparable to the peak load of Guyana is presented in Table 7.1.



**Table 7.1: Reserve Capacity Margins for Island Utilities<sup>8</sup>**

Peak Load, MW	Reserve Margin, %	Largest Generation Unit, MW	Reserve Margin, MW	Reserve Margin to Largest Generation Unit Capacity Ratio
67.00	50%	13.70	33.50	2.45
74.00	100%	35.00	74.00	2.11
79.50	40%	20.00	31.64	1.58
90.00	38%	13.00	34.20	2.63
112.30	51%	20.00	57.27	2.86
166.00	40%	30.00	66.40	2.21
183.00	32%	20.00	57.65	2.88
435.00	43%	72.00	187.05	2.60

As can be seen from the above table, the reserve margin for all the island power systems in the table is significantly higher than 15% of the peak load, as recommended by the Expansion Study and based on larger interconnected systems. However, almost all of the systems have their margins at between 2 and 3 times the capacity of the largest unit. Based on that, K&M considers that setting the minimum reserve margin requirement at 2 times the capacity of the largest unit is technically justified and commonly used approach while using 15% of peak load for establishing the reserve margin is applicable to larger interconnected systems.

For the purposes of our analysis, K&M used a conservative approach of establishing the target reserve margin at 2 times of the capacity of the largest unit or 15% of peak load, whichever is higher.

It should be noted that another commonly used method for calculating reserve margin target is a probabilistic method based on the Loss of Load Expectation (LOLE) analysis. This method determines a more precise value for the required reserve margin and may further optimize reserve margin investment requirements. Conducting such analysis is beyond the scope of this study. GPL may consider engaging a power system reliability expert to conduct such LOLE analysis to further optimize the reserve margin requirements and associated investments.

### 7.2.1 Possible Maximum Sizes of New Gas Fired Power Plants

The possible maximum sizes of the new gas fired power plants based on heat and material balances calculated by K&M for different technology options for 30 MMscfd and 50 MMscfd Natural Gas flow as described in more detail in Section 7.3 are presented in Table 7.2 below.

**Table 7.2: Maximum Gas Plant Capacities for Different Technology Options and Gas Flows**

Option	30 MMscfd	50 MMscfd
SGT400 SC	108	194
SGT400 CC	155	279

<sup>8</sup> Reliability economies of scale for tropical island electric power. Peter C. Mayer. Energy Economics 22. 2000.



Option	30 MMscfd	50 MMscfd
LM2500 SC	127	212
LM2500 CC	180	300
Wartsila	153	255

## 7.2.2 Required Firm Capacity Additions

The additional new capacity requirements estimated based on the approach to determining the required reserve margin for options with the largest capacity lost with a single unit at 17 MW (for Wartsila RICE technology option) or 30 MW (for GE LM2500 CC technology option) are presented in Table 7.3 below:

**Table 7.3: Estimated DBIS System New Capacity Requirements**

Year	2023	2024	2025	2026	2027	2028	2029	2030	2031	2032	2033	2034	2035
Maximum Load, MW	154	194	224	256	291	317	319	321	323	325	327	329	330
<b>Wartsila RICE Option</b>													
Reserve Margin based on 15 % of Peak Load, MW	23	29	34	38	44	48	48	48	48	49	49	49	50
Reserve margin based on 2 times capacity of the largest unit, MW	34	34	34	34	34	34	34	34	34	34	34	34	34
Target firm capacity with reserve margin, MW	188	228	258	294	334	365	367	369	371	374	376	378	380
HFO Capacity	127	127	127	127	127	127	127	127	127	127	127	116	116
Hydro power plant capacity (for 30 MMscfd scenario), MW					165	165	165	165	165	165	165	165	165
<b>Required Additional Firm Capacity for 30 MMscfd scenario, MW</b>	<b>61</b>	<b>101</b>	<b>131</b>	<b>167</b>	<b>42</b>	<b>73</b>	<b>75</b>	<b>77</b>	<b>79</b>	<b>82</b>	<b>84</b>	<b>97</b>	<b>99</b>
<b>Required Additional Firm Capacity for 50 MMscfd scenario, MW</b>	<b>61</b>	<b>101</b>	<b>131</b>	<b>167</b>	<b>207</b>	<b>238</b>	<b>240</b>	<b>242</b>	<b>244</b>	<b>247</b>	<b>249</b>	<b>262</b>	<b>264</b>
<b>LM 2500 CC Option</b>													
Reserve Margin based on 15 % of Peak Load, MW	23	29	34	38	44	48	48	48	48	49	49	49	50
Reserve margin based on 2 times capacity of the largest unit, MW	60	60	60	60	60	60	60	60	60	60	60	60	60
Target firm capacity with reserve margin, MW	214	254	284	316	351	377	379	381	383	385	387	389	390
HFO Capacity	127	127	127	127	127	127	127	127	127	127	127	116	116

Year	2023	2024	2025	2026	2027	2028	2029	2030	2031	2032	2033	2034	2035
Hydro power plant capacity (for 30 MMscfd scenario), MW					165	165	165	165	165	165	165	165	165
<b>Required Additional Firm Capacity for 30 MMscfd scenario, MW</b>	<b>87</b>	<b>127</b>	<b>157</b>	<b>189</b>	<b>59</b>	<b>85</b>	<b>87</b>	<b>89</b>	<b>91</b>	<b>93</b>	<b>95</b>	<b>108</b>	<b>109</b>
<b>Required Additional Firm Capacity for 50 MMscfd scenario, MW</b>	<b>87</b>	<b>127</b>	<b>157</b>	<b>189</b>	<b>224</b>	<b>250</b>	<b>252</b>	<b>254</b>	<b>256</b>	<b>258</b>	<b>260</b>	<b>273</b>	<b>274</b>

As can be seen from the above, maximum possible capacities of the new gas fired power plants for 30 MMscfd Natural Gas flow are below the minimum new firm capacity requirements starting from year 2026, but is sufficient starting from 2027 when the new hydro power plant is planned to be put into operation. K&M recommends GPL to consider constructing the new hydro power plant a year earlier to ensure sufficient reserve margin in 2026.

For 50 MMscfd the maximum possible capacity exceeds the new firm capacity requirements for all the years through 2035 for the combined cycle option. For the Wartsila RICE option the maximum possible capacity of the new gas fired power plant is 9 MW below the target based on 15% reserve margin calculation but is sufficient in case of calculating the margin at 2 times the capacity of the largest unit. Still, K&M recommends GPL to install additional firm capacity in 2035 to cover future load growth.

Based on the above, K&M conducted an economic evaluation of all the technology options for 30 MMscfd Natural Gas flow using the estimated maximum plant capacities as presented in Table 7.2. For the 50 MMscfd Natural Gas flow, K&M initially considered limiting the maximum capacity of the new gas fired plant to 264 MW equal to the capacity required to be added by 2035. However, when taking into consideration standard sizes of gas turbines and reciprocating engines available on the market and possible plant configurations for combined cycle options (it is more practical to have the plant built as several 2 x 1 trains where two gas turbines are connected to a single steam turbine, which requires even number of gas turbines), it was decided to perform the analysis based on the capacities presented in Table 7.2 without modifications. Doing so would also increase the total system reserve margin for some of the cases, which would result in improved reliability of the Guyana power system.

For simple cycle options the gas fired plant size is below the required additional capacity. For option evaluation purposes the capacity deficit for simple cycle options is assumed to be made up by additional HFO capacities.

K&M also verified that the gradual capacity increase of the new power plant following the load increase as recommended by the Expansion Study is economically more beneficial than constructing the new gas fired power plant in one or two large phases and taking advantage of significantly reducing or completely eliminate generation using HFO. Based on the results of this optimization, it was confirmed that the approach recommended by the Expansion Study is optimal. Therefore, for the economic analysis K&M used the schedule of capacity additions specified in the Expansion Study.

### 7.2.3 Plant Configuration Considerations

The plant configuration is typically defined based on the following considerations:

- Plant capital cost and heat rate. Use of lower number of larger units for power plants typically results in lower capital cost and better heat rate. Based on this consideration alone, the best configuration for the new gas power plant would be a 1 x 1 or 2 x 1 (one gas turbine connected to one steam turbine or two gas turbines connected to one steam turbine) configuration for combined cycle options and using the largest reciprocating engines available on the market for the reciprocating engine option.
- System stability. Though using large units could be economically beneficial, for relatively small power systems like DBIS system stability and reliability considerations take precedence over economic considerations. Instantaneous loss of generating capacity resulting from a trip of a single largest unit should typically not exceed 10% of the peak load as tripping of larger units can cause system instability. Based on the DBIS system demand projections, 10% of the peak load would be 23 MW and 33 MW in 2023 and 2035 respectively. K&M believes that the loss of capacity associated with a loss of a single largest unit should not exceed 30 MW.
- Size of reserve margin. Typically, capacity reserve margin should be sufficient to cover the loss of the two largest units. Using larger power units would require additional investment to provide sufficient reserve margin. For year 2023 with a projected peak load of 232 MW the target reserve margin using Wartsila RICE option would mean reserve capacity of 34 MW while for a LM2500 combined cycle option the required reserve margin would be 60 MW.

Based on the above, the technology options in Section 7.3 considered gas turbines and reciprocating engines in either simple or combined cycle configurations sized so that in case of a unit trip the total capacity loss to the DBIS system would not exceed 30 MW.

### 7.3 Technology Options

This section of the report provides a high-level description of the generating technologies that were considered in the study. While the thermal engineering design and simulation software used to develop the heat balances (GT PRO/PEACE) requires specific engine models to create the plant performance models, most of engines used for modeling have similar equipment offered by other vendors, and the final equipment selection should be determined by competitive bidding. The results of the performance and economic modeling in this report are intended to compare types of generation technology, and not specific vendor offerings.

The small size of Guyana's power grid makes it susceptible to instability caused by generating unit trips, and therefore effectively limits the size of individual generating units. The size of the largest unit will be driven by the maximum capacity loss that can be withstood by the power grid without risking a blackout. In the size range needed by Guyana, the types of generating resources that are practical fall into three categories:

- Option 1: GTs of ~15-MW range in Simple Cycle
- Option 2: GTs of ~15-MW range in Combined Cycle
- Option 3: GTs of ~25-MW range in Simple Cycle
- Option 4: GTs of ~25 MW range in Combined Cycle
- Option 5: Medium Speed Reciprocating Internal Combustion Engines (18 MW ea. or smaller)

GT stands for gas turbines, which are combustion turbines that can operate with either natural or light distillate liquid fuels such as diesel oil. Among combustion turbines, two different types were considered in this study: heavy frame industrial units and aeroderivative units, each of them with its own advantages and disadvantages.

Aeroderivative gas turbines are, as their name describes, adaptations of gas turbines used in aircraft ("jet" engines). Aircraft engine performance is driven by thrust to weight ratio and require the engine to run at different speeds depending on where you are in the flight envelope (think take-off vs cruising). As a result, aeroderivatives are generally lighter weight, physically smaller, have better throttle response, start times, and better part load performance. The primary trade-off is lower operating life, sometimes higher maintenance, and generally higher life-cycle cost.

Heavy frame industrial gas turbines are designed assuming they will operate on the ground. They can be designed to have very high capacities and efficiencies, are more robust, typically have lower operating costs, and are optimized to run at full power.

Guyana requires that new power plants will be able to run on either fuel oil or Natural Gas. The primary fuel will be Natural Gas, supplied from an offshore pipeline. In case of a Natural Gas supply interruption, Guyana will have fuel oil available to prevent disruption in plant output. Therefore, only units with dual fuel capability were considered in this study.

GTs were evaluated both in Simple Cycle and Combined Cycle plant configurations.

Simple Cycle power plants consist of a gas turbine that is connected to an electrical generator. The simple cycle combustion turbine follows the Brayton thermodynamic cycle and differs from a combined cycle operation in that it has only one power cycle (i.e. no provision for waste heat recovery).

The term "Combined Cycle" refers to the combining multiple thermodynamic cycles to generate power. Combined Cycle operation employs a heat recovery steam generator (HRSG) that captures heat from the high temperature exhaust gases of combustion turbines or reciprocating engines to produce steam, which is then supplied to a steam turbine to generate additional electric power. The process for creating steam to produce work using a steam turbine is based on the Rankine thermodynamic cycle.

The most common type of combined cycle power plant utilizes combustion turbines, because of their higher exhaust temperatures than reciprocating engines, and such configuration is called a combined cycle gas turbine (CCGT) plant. Because gas turbines have relatively low efficiency in simple cycle operation, the output produced by the steam turbine accounts for about one third of the CCGT plant output. There are many different configurations for CCGT power plant blocks, but typically each combustion turbine has its own associated HRSG, and multiple HRSGs supply steam to one or more steam turbines. For example, at a plant in a 2x1 configuration, two GT/HRSG trains supply to one steam turbine; likewise, there can be 1x1, 3x1, 4x1, 5x2, and other arrangements, though arrangements with more than 2x 1 are less common. The steam turbine is sized to the number and capacity of supplying GTs/HRSGs.

Medium-speed reciprocating internal combustion engines (RICE) units similar to the ones already installed in Guyana were also considered. A RICE mixes pressurized air with fuel, converting the linear movement of a piston to the rotating movement of a crankshaft. In a power plant, this rotating movement turns a generator to create electricity.

A RICE differs from a combustion turbine in that it performs combustion intermittently, whereas a combustion turbine performs combustion continuously. To produce continuous power, a RICE needs to have multiple pistons connected to the crankshaft, which allow it to rotate continuously. A RICE also differs from a combustion turbine in size, being much larger than a combustion turbine of comparable capacity. As such, the largest size for a RICE is also limited by what is practical to transport.

If multiple RICE units are installed, they can share certain common facilities and equipment, which helps to lower the project's capital cost. Having multiple RICE units in operation also increases overall system flexibility, as the combined system can more easily accommodate load swings.

### 7.3.1 GTs of ~15MW range in Simple Cycle

The information presented in section 7.3.1 and 7.3.2 for the ~15 MW range is based on the Siemens SGT-400 industrial gas turbine, which is not being pre-selected but considered as a representative of a typical combustion turbine in this range for the purposes of this study. The SGT-400 has been on the market for 20 years obtaining over 5 million operating hours across more than 390 units sold. This dual fuel, twin-shaft gas turbine offers one of the highest simple-cycle efficiencies at 35% nominal and is able to reliably provide 10-15 MW of base load, standby power, or peak lopping to simple and combined cycle power plants by transitioning seamlessly between fuel types without losing production. It's can-annular combustor design allows the turbine to burn a variety of gaseous and liquid fuel types and qualities including gases with high inert content while meeting even the most rigorous emissions standards by utilizing its Dry Low Emissions combustion system technology. With a fast start up time of 15 minutes, this turbine can provide maximum load quickly as needed to provide flexible grid reliability. If certain options are purchased and standby conditions are maintained, the engine can be brought on line even faster than cited here.

Figure 7.2 below shows the results of the GT PRO heat and material balance calculations for Option 1.

**Figure 7.2: Heat Balance for Option 1 (typical)**

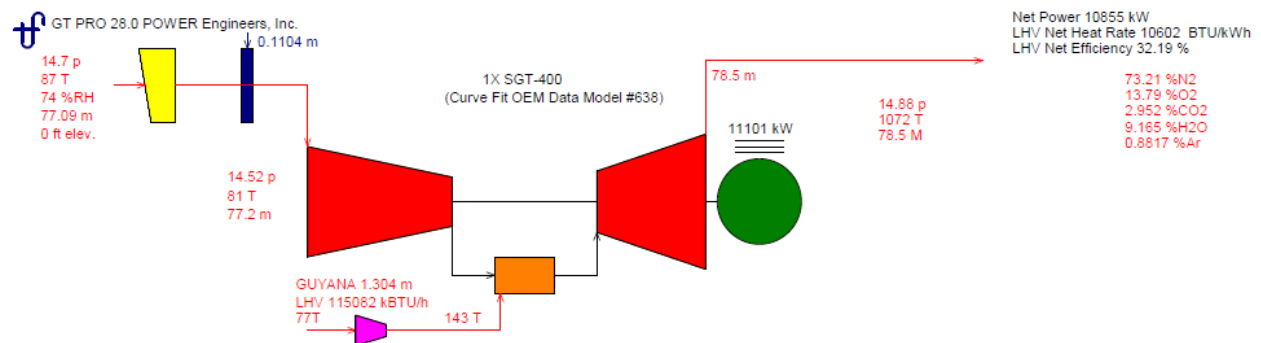

Source: K&M-Power Engineers

**Note (typical)**

Units are: for pressure (P): psia; for temperature (T): degrees Fahrenheit; and for mass flow (M): lb/s.  
Steam properties are based on IFC-67

### Operational Features & Benefits

The primary advantages of simple cycle include:

- High power generated to weight (or size) ratio, when compared to alternatives.
- Fast startup and ramp to full power.
- High reliability which permits long-term unattended operation.
- The initial investment costs (capex) are cheaper in simple cycle than in combined cycle combustion turbine plants.
- Short construction period.
- GTs in simple cycle do not require external cooling water supply.
- Short maintenance inspection outages.
- Low emissions.

### **Risks / disadvantages**

The major disadvantage of GTs in Simple Cycle is low thermal efficiency. Simple Cycle thermal efficiency is significantly lower than that of RICE units and Combined Cycle configuration. Therefore, although simple cycle plants may be less expensive to build, their fuel consumption and resulting operating costs are substantially higher than for combined cycle or RICE power plants.

Other disadvantages include:

- Heat Rate increases (efficiency decreases) at partial loads.
- Power output falls at higher ambient temperatures.
- Use of expensive light distillate oil as backup fuel.

### **7.3.2 GTs of ~15MW range in Combined Cycle**

As indicated above in Section 7.3.1, the information presented in this section is based on the Siemens SGT-400 industrial gas turbine.

Figure 7.3 below shows the results of the GT PRO heat and material balance calculations for Option 2.

**Figure 7.3: Heat balance for Option 2 (typical)**

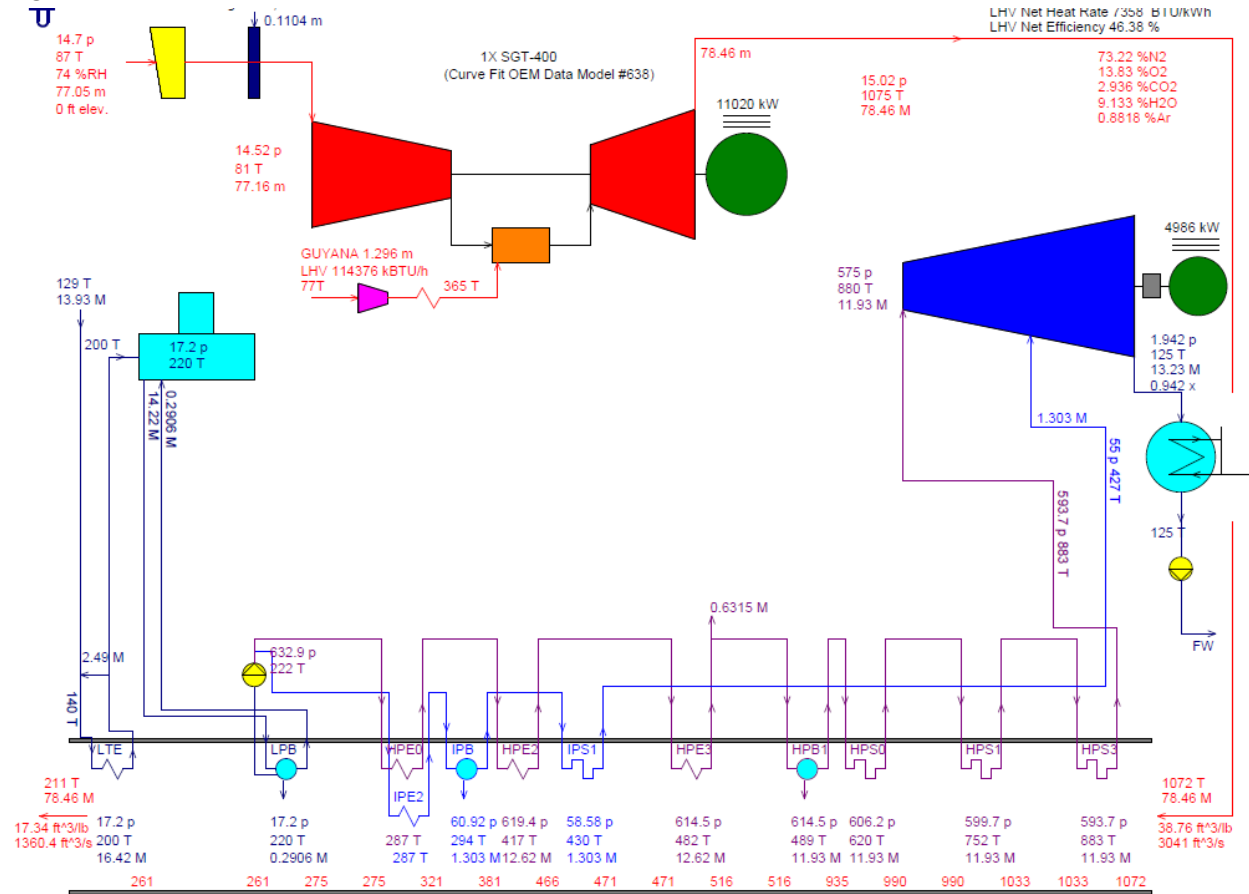

Source: K&M-Power Engineers

**Note**

Units are: for pressure (P): psia; for temperature (T): degrees Fahrenheit; and for mass flow (M): lb/s.  
Steam properties are based on IFC-67

**Operational Features & Benefits**

The operational features and benefits of Combined Cycle options include:

- High overall thermal efficiency at full load.
- Larger inertia of gas turbines compared vs RICE units provides some benefit for grid stability purposes during frequency excursion events.
- Low emissions.

**Risks / disadvantages**

The following are risks/disadvantages of Combined Cycle:

- More complex design
- Combined cycle configuration involves more auxiliary systems which increase the headcount of operational staff required, maintenance costs, and the required level of skills and training for the personnel.

- Unless GT are equipped with a Diverter Damper, a trip or outage of a single GT or ST will cause the entire plant to be unavailable.
- Increased footprint and land use restrictions, because of the addition of the steam cycle.
- High demand for external supply of water for condenser cooling and steam cycle makeup.
- The HRSGs present operational constraints on the CCGT power plant. As the HRSGs are located directly downstream of the gas turbines, changes in temperature and pressure of the exhaust gases cause thermal and mechanical stress. When CCGT power plants are used for load-following operation, characterized by frequent starts and stops or operating at part-load to meet fluctuating electric demand, this cycling can cause thermal stress and eventual damage in some components of the HRSG.
- Slow start-up. The HRSG takes longer to warm up from cold conditions than from hot conditions. As a result, the amount of time elapsed since last shutdown influences startup time. When gas turbines are ramped to load quickly, the temperature and flow in the HRSG may not yet have achieved conditions to produce steam, which causes metal overheating since there is no cooling steam flow. In 1x1 configurations, the operation of the steam turbine is directly coupled to the GT/HRSG operation, limiting the rate at which the power plant can be ramped to load. Steam conditions acceptable for the steam turbine are dictated by thermal limits of the rotor, blade, and casing design.

### 7.3.3 GTs of ~25MW range in Simple Cycle

The information presented in sections 7.3.3 and 7.3.4 for the ~25 MW range is based on the GE LM2500 aeroderivative gas turbine, which is not being preselected but considered as a representative of a typical combustion turbine in this range for the purposes of this study. The GE LM2500 is one of the most prominent gas turbines servicing 22-34 MW applications across the globe with over 2,100 units sold and 75 million operating hours. Operating with up to 36% efficiency in simple-cycle mode, this gas turbine can reach full load capability within 15 minutes and boasts greater than 99% and 98% in reliability and availability, respectively. If certain options are purchased and standby conditions are maintained, the engine can be brought on line even faster than cited here. The fuel flexibility of various models of the LM2500 allows it to run on several different fuels including coke oven gas, naphtha, propane, diesel, ethanol and liquid Natural Gas, making it one of the most versatile gas engines in its class. The Dry Low Emissions technology enables the turbine to meet emissions standards by allowing for NOx abatement.

Figure 7.4 below shows the results of the GT PRO heat and material balance calculations for Option 3.



**Figure 7.4: Heat balance for Option 3 (typical)**

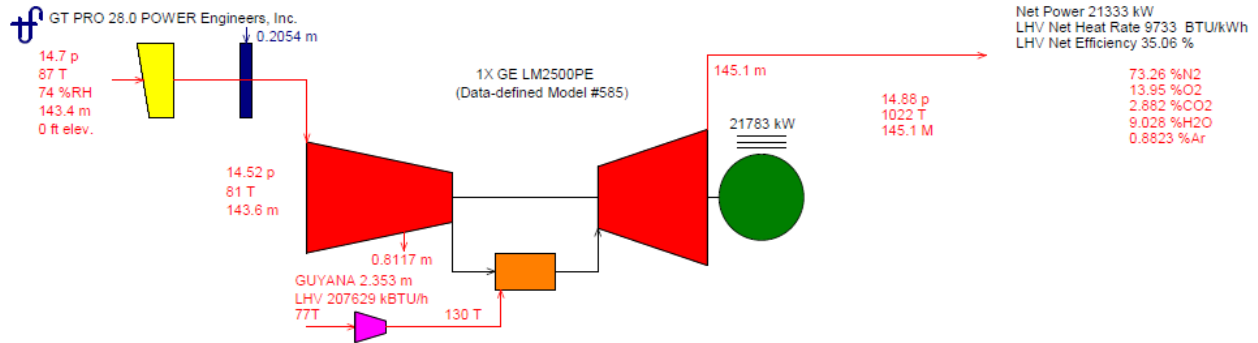

Source: K&M-Power Engineers

**Note**

Units are: for pressure (P): psia; for temperature (T): degrees Fahrenheit; and for mass flow (M): lb/s.  
Steam properties are based on IFC-67

**Operational Features & Benefits**

Benefits identified for GT in simple cycle configuration in 7.3.1 are also applicable here.

**Risks / disadvantages**

Risks identified for GT in simple cycle configuration in 7.3.1 are also applicable here. Additionally, since the unit capacity for this option is larger than for Options 1 and 2, unit trip would cause higher stress on the DBIS system. System reserve margin requirements can also be affected.

**7.3.4 GTs of ~25MW range in Combined Cycle**

As indicated above in 7.3.3, the information presented in this section is based on the GE LM2500 aeroderivative gas turbine.

Figure 7.5 below shows the results of the GT PRO heat and material balance calculations for Option 4.

**Figure 7.5: Heat balance for Option 4 (typical)**

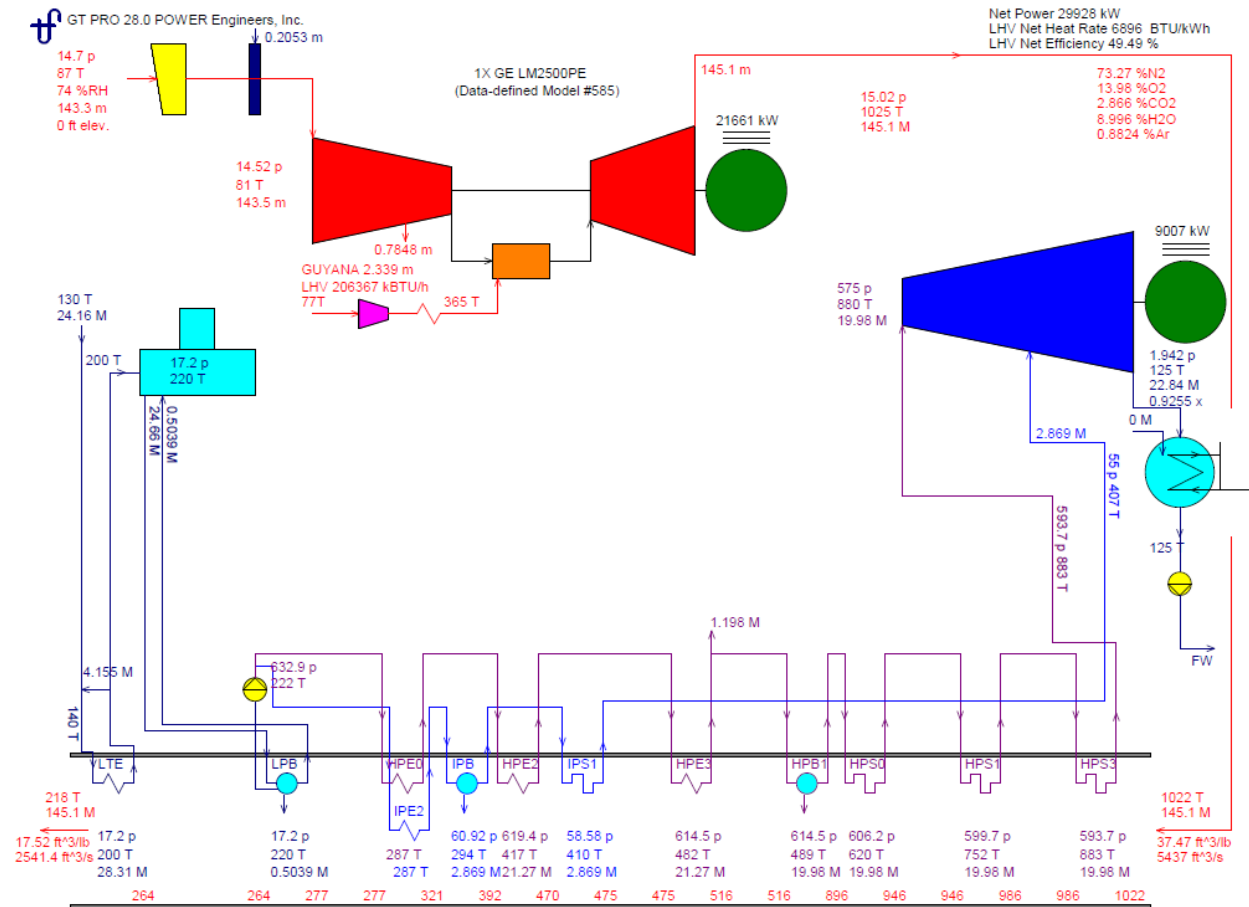

Source: K&M-Power Engineers

**Note**

Units are: for pressure (P): psia; for temperature (T): degrees Fahrenheit; and for mass flow (M): lb/s.  
 Steam properties are based on IFC-67

**Operational Features & Benefits**

The benefits identified for combined cycle configuration in 7.3.2 are also applicable here.

**Risks / disadvantages**

- The trip of single GT unit can cause the instantaneous loss of 30 MW of capacity, which given the size of Guyana electric system may create a risk to grid stability.

Other risks identified for combined cycle configuration in 7.3.2 are also applicable here.

**7.3.5 Medium-speed Reciprocating Internal Combustion Engines**

The information presented in section 7.3.4 is based on the Wartsila 18V50DF engine, which is not being preselected but considered as a representative of a typical medium speed RICE unit in the ~15 MW range for the purposes of this study. Wartsila is a leader in the medium-speed reciprocating engine market, with a fleet of engines located across 176 countries with a total

power capacity of 63 GW. Since the 50DF engine's launch in 1992, 4,000 units have been installed worldwide and since 2006, 65% of new LNG carrier ships have installed Wartsila dual-fuel engines.

Figure 7.6 below shows the results of the GT PRO heat and material balance calculations for Option 5.

**Figure 7.6: Heat balance for Option 5 (typical)**

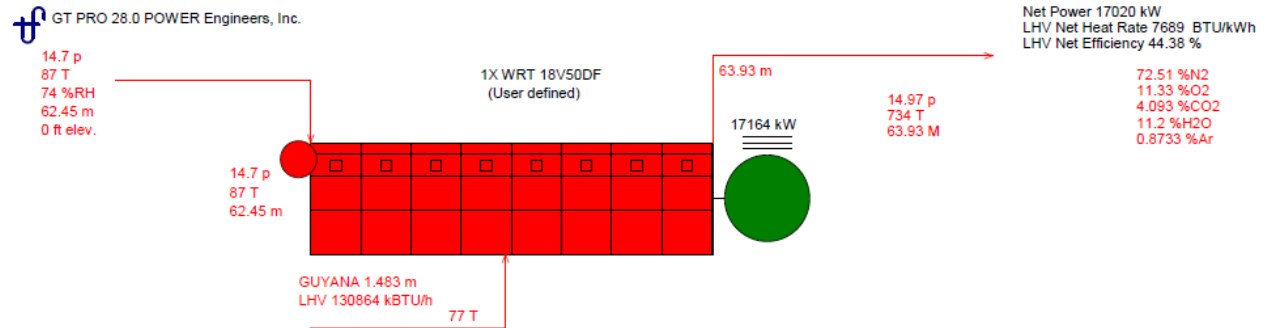

Source: K&M-Power Engineers

**Note**

Units are: for pressure (P): psia; for temperature (T): degrees Fahrenheit; and for mass flow (M): lb/s.  
Steam properties are based on IFC-67

**Operational Features & Benefits**

- Efficiency is higher than for simple cycle GTs.
- High efficiency at part load operation.
- Fast startup performance and operational flexibility.
- Can be used in island mode (all ships do this) with good load following capability.
- Low gas admission pressure requirements for engines (6 bars comparing to around 21 - 40 bar for turbines) reduces infrastructure costs and risks and allows placing of such generators close to the consumers.
- The engine technology is less sensitive to hot ambient temperatures.
- Multi-fuel capability, being able to also use HFO as fuel. The Wartsila 50DF operates reliably on light fuel oil, heavy fuel oil, or Natural Gas and can continue operation without power loss when switching between these fuels.
- Can be designed with no external supply of water for cooling.
- Guyana generating systems already includes RICE units which are well known by local engineers and technicians and would require a level of skills and training for the plant O&M staff lower than required for gas turbines, especially in combined cycle configuration.

**Risks / disadvantages**

- Efficiency at full load is lower than for GTs in Combined Cycle.
- Higher NOx emissions.

- RICE plant footprint is larger than those of typical gas turbines in simple cycle. Require substantially strong foundations.
- Higher maintenance requirements and costs, including labor for routine inspections and procedures, and major overhauls.
- Lower power-to-weight ratio.

### 7.3.6 Summary of technology options considered

The tables below (Table 7.4 and Table 7.5) summarize the generating resources which were considered for this study. The values in these tables are intended to be used in the dispatch and generation planning economic analysis in this report. Each of the generating alternatives listed are representative of a class of applicable generation technology. For this reason, the values presented should be considered typical as they will vary depending on the site-specific characteristics and depending on exactly what model and plant configuration each vendor offers in response to a solicitation.

The cost characteristics presented below are intended to be used for option analysis and are typical. The costs do take into consideration the difference in the required plant area, as this is important for options analysis, but does not consider costs associated with site access by road, constructing of a jetty, and costs required to improve climate resilience, as these costs are expected to be similar for all the options and would not impact the option analysis. These costs are considered in the cost estimates prepared for the two best options presented in Section 12 of this Final Report.

**Table 7.4: Capacity and Cost Characteristics of Generating Resources Considered in this Study**

Resources	Summer Capacity (MW)	Installed Cost (\$/kW)	LHV Net Heat Rate (BTU/kWh)	Max Daily Fuel Gas Consumption (MMSCFD)
SGT400 SC	10.8	1,503	10,671	2.75
SGT 400 CC	15.5	1,816	7,382	2.74
LM2500 SC	21.2	1,238	9,785	4.97
LM2500 CC	30.0	1,517	6,915	4.94
Wartsila	17	950	7,689	3.13

**Note**

The information in Table 7.5 is based on plant performance models created using GT PRO/PEACE software from Thermoflow. Heat balances were generated using GT PRO and cost estimates were generated using PEACE.

**Table 7.5: Other Technical Characteristics of Generating Resources Considered in this Study**

Resources	30 MMSCFD Fuel Gas Limit				50 MMSCFD Fuel Gas Limit			
	Number of Units	Total Capacity (MW)	Footprint (m2)	Capex Cost Adjustment (US\$ millions)	Number of Units	Total Capacity (MW)	Footprint (m2)	Capex Cost Adjustment (US\$ millions)
SGT 400 SC	10	108	25,000	3.4	18	194	36,000	4.9

Resources	30 MMSCFD Fuel Gas Limit				50 MMSCFD Fuel Gas Limit			
	Number of Units	Total Capacity (MW)	Footprint (m2)	Capex Cost Adjustment (US\$ millions)	Number of Units	Total Capacity (MW)	Footprint (m2)	Capex Cost Adjustment (US\$ millions)
SGT 400 CC	10	155	44,000	5.9	18	279	57,000	7.7
LM 2500 SC	6	127	22,000	3.0	10	212	32,000	4.3
LM 2500 CC	6	180	35,000	4.7	10	300	54,000	7.3
Wartsila	9	153	24,000	2.8	15	255	30,000	3.8

**Note**

1. The Capital Cost Adjustment values included in Table 7.5 are to account for difference in area required for different technology options and soil conditions of generic site located in a coastal area. Since port and other external infrastructure would be the same for all the options, these costs were not considered.
2. The per-kW cost estimate included in Table 7.5 are based on the output of the GT-Pro software and its' extension, PEACE, which contains a regularly updated database of costs for different technologies.

The supply of Natural Gas for the new power plant may be limited to either 30 MMSCFD or 50 MMSCFD. Aside from the footprint estimates that were generated using PEACE, the rest of the information in Table 7.5 (Number of Units, Total Capacity, and Site-Specific Capital Cost Adjustments) is calculated given this restricted availability on fuel gas. The Site-Specific Capital Cost Adjustments depend on the footprint of the new power plant. The total cost for the new power plant used for economic evaluation of the options include both the Installed Cost (from Table 7.4) and the Site-Specific Capital Cost Adjustment (Table 7.5).

One additional point to consider for technical comparison of all the alternatives in the long term is the aging effect on the prime mover's performance (GT or RICE).

**Figure 7.7: Aging effect comparison**

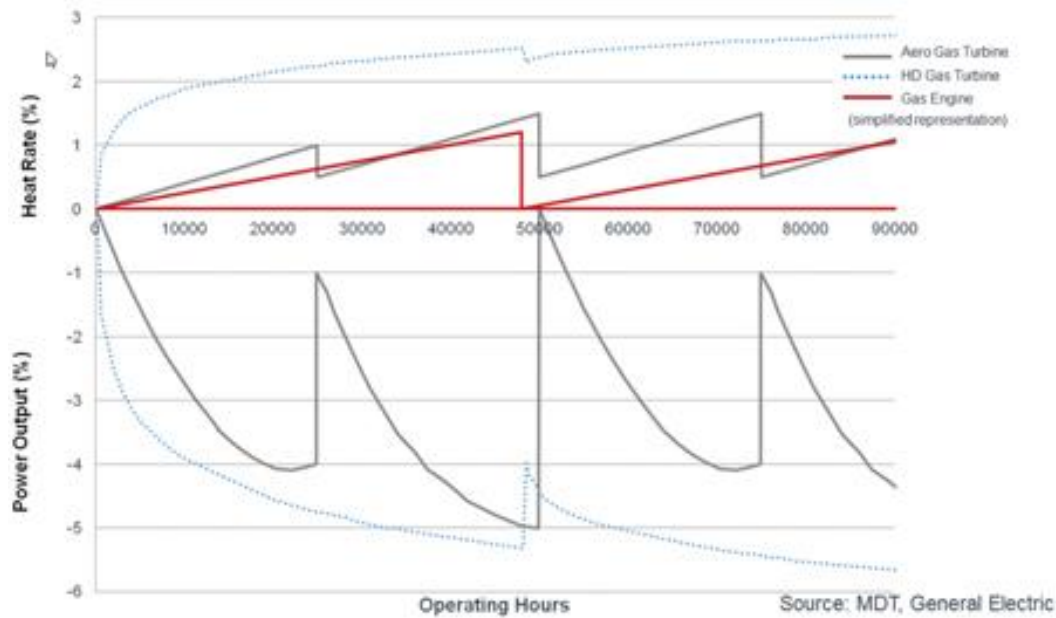

Source: MDT, GE, Power Engineering Magazine

**Note**

The above curves are typical of each technology and not specific to the GT and RICE models mentioned in this study

Figure 7.7 above shows how the gas turbines are much more affected by non-recoverable loss of performance as they accumulate hours of operation than RICE units. The non-recoverable loss is primarily due to increase in clearance of turbine and compressor and changes in surface finish and airfoil contour. Due to this, there is a reduction in component efficiencies. This reduction cannot be recovered by operational procedures, external maintenance or compressor cleaning and is only recoverable through replacement of affected parts at recommended inspection intervals.

The technical advantages and disadvantages of all options considered were summarized in Table 7.6

**Table 7.6: Technical Advantage/Disadvantage Summary**

Option	Description	Pros	Cons
1	~15-MW SCGT, heavy duty GT	<ul style="list-style-type: none"><li>• High power-to-weight ratio</li><li>• Fast startup and ramp to full power</li><li>• High reliability</li><li>• Short construction period</li><li>• No external cooling water required</li><li>• Short maintenance outages</li><li>• Low emissions</li></ul>	<ul style="list-style-type: none"><li>• Low efficiency at partial load</li><li>• Power output falls at high ambient temperature</li><li>• Use of expensive light distillate oil as backup fuel</li></ul>
2	~15-MW CCGT, heavy duty GT	<ul style="list-style-type: none"><li>• High overall efficiency at full load</li><li>• Larger inertia helps grid stability</li></ul>	<ul style="list-style-type: none"><li>• Complexity, more auxiliary systems</li><li>• Increased O&amp;M costs, headcount</li><li>• Slow startup and ramp up</li><li>• Increased footprint</li><li>• External water supply required for cooling and steam cycle makeup</li><li>• Less operational flexibility for load following or cycling (thermal stress)</li><li>• A single unit trip may cause unavailability of the whole block</li></ul>

Option	Description	Pros	Cons
3	~25-MW SCGT, aeroderivative GT	<ul style="list-style-type: none"> <li>• High power to weight ratio</li> <li>• Fast startup and ramp to full power</li> <li>• High reliability</li> <li>• Short construction period</li> <li>• No external cooling water required</li> <li>• Short maintenance outages</li> <li>• Low emissions</li> </ul>	<ul style="list-style-type: none"> <li>• Low efficiency at partial load</li> <li>• Power output falls at high ambient temperature</li> <li>• Use of expensive light distillate oil as backup fuel</li> <li>• Bigger units' trip would cause higher stress on the grid and affect reserve margin requirements</li> </ul>
4	~25 MW CCGT, aeroderivative GT	<ul style="list-style-type: none"> <li>• High power to weight ratio</li> <li>• Fast startup and ramp to full power</li> <li>• High reliability</li> <li>• Short construction period</li> <li>• No external cooling water required</li> <li>• Short maintenance outages</li> <li>• Low emissions</li> </ul>	<ul style="list-style-type: none"> <li>• Low efficiency at partial load</li> <li>• Power output falls at high ambient temperature</li> <li>• Use of expensive light distillate oil as backup fuel</li> <li>• Bigger units' trip would cause higher stress on the grid and affect reserve margin requirements</li> </ul>
5	~15 MW MS RICE	<ul style="list-style-type: none"> <li>• Higher thermal efficiency than SCGT</li> <li>• Very fast startup and ramping</li> <li>• High operational flexibility for cycling and load following</li> <li>• Island mode operation</li> <li>• Less sensitive to hot ambient temperature</li> <li>• Multi-fuel capability, including HFO</li> <li>• GPL's previous experience with this technology.</li> </ul>	<ul style="list-style-type: none"> <li>• Full load efficiency is lower than CCGT</li> <li>• Higher NOx emissions than GTs</li> <li>• Larger footprint than GTs, stronger foundations required</li> <li>• Higher maintenance costs</li> <li>• Lower power-to-weight ratio</li> </ul>

Source: K&M

## **8 Gas Availability, Properties, and Delivery Arrangements,**

---

Natural gas from the offshore Floating Production and Storage and Offloading (FPSO) unit to the site is expected to be delivered via a 12-inch high pressure underwater pipeline. This Natural Gas will be treated at on shore gas processing facility by removing higher hydrocarbons such as propane, butane, and other condensable gases, reducing gas pressure to the level required by the power plant equipment, and then delivered via an on-shore gas pipeline to the power plant. The Natural Gas supplier is expected to be responsible for constructing the underwater pipeline and the gas treatment plant. It is expected that the interface point for the treated dry gas supply pipeline between the gas supplier and the power plant will be either at the power plant or the gas treatment plant site boundary. Since both the gas processing facility and the power plant are assumed to be located within the same generic site area, the gas pipeline between the gas processing facility and the power plant will be fairly short, and there will be no right of way or land ownership issues associated with its construction.

According to the Exxon Mobil, the Natural Gas pressure at inlet to the gas processing facility is expected to be 1,800 psig and can be reduced at the power plant delivery point to the level required by the power plant equipment manufacturers. Therefore, no Natural Gas compressors will need to be installed as part of the power plant scope.

Based on the discussion in Section 6, K&M does not expect that any of the existing plants will be converted to Natural Gas, so there will be no on-shore gas pipelines between the generic site and Georgetown area.



## 9 Cost/Benefit Analysis of the Alternatives

### 9.1 Methodology

For the options described in the previous section, K&M conducted an economic analysis that calculated the Levelized Cost of Energy (LCOE) for GPL's entire electrical system. The LCOE is defined as the average unit cost of electricity, calculated as the PV (Present Value) of total electricity costs divided by PV of total electricity demand over the forecast period (expressed in US\$ per MWh).

The LCOE was calculated for each option with 30 MMscfd and 50 MMscfd gas supply over the forecast period of 28 years (2020 – 2047). A 28-year forecast would allow for economic assessment of different options for 25 years of operation and 3 years of construction for the new power plant. Since the Expansion Study only covered the forecast period till 2035, the forecast from 2036 to 2047 was estimated by increasing the generation forecast using the average growth rate for the preceding 5 years (2031 – 2035).

The options considered in the analysis are described in Section 7 and are also presented below:

**Table 9.1: Capacity and Cost Characteristics of Generating Resources Considered in this Study**

Option No	Resources	Summer Capacity (MW)	Installed Cost (\$/kW)	LHV Net Heat Rate (BTU/kWh)	Max Daily Fuel Gas Consumption (MMSCFD)	30 MMSCFSD Fuel Gas Limit		50 MMSCFD Fuel Gas Limit	
						Number of Units	Total Capacity (MW)	Number of Units	
1	SGT400 SC	10.8	1,503	10,671	2.75	10	108	18	194
2	SGT 400 CC	15.5	1,816	7,382	2.74	10	155	18	279
3	LM2500 SC	21.2	1,238	9,785	4.97	6	127	10	212
4	LM2500 CC	30.0	1,517	6,915	4.94	6	180	10	300
5	Wartsila	17.0	950	7,689	3.13	9	153	15	255

The per-kW cost estimate included in Table 7.5 are reproduced in Table 9.1 are based on the output of the GT-Pro software and it's extension, PEACE, which contains a regularly updated database of costs for different technologies. The Capital Cost Adjustment values included in Table 9.1 are to account for difference in area required for different technology options and soil conditions of a generic site located in a coastal area. Since port and other external infrastructure would be the same for all the options, these costs were not considered for option analysis

#### 9.1.1 Capacity and Generation Forecasts

The maximum generation and the capacity forecast for each option through 2035 was calculated from the peak capacities used in the load duration curves discussed in Section 4. The generation and capacity numbers were compared to the forecasts in the Expansion Study and the generation

used in the analysis was within 1% of the expansion study. As explained in the previous section, the generation and capacity forecast between years 2036 and 2047 was estimated by increasing the generation using the average growth rate used in the Expansion Study for the preceding five years (2031 – 2035). The peak demand was calculated using 0.755 as the system load factor (from Expansion Study).

**Table 9.2: Generation and Capacity Forecasts**

All units in MW, unless otherwise noted	2020	2021	2022	2023	2024	2025	2030	2035	2040	2047
<b>Peak Demand</b>	<b>125</b>	<b>129</b>	<b>133</b>	<b>154</b>	<b>194</b>	<b>224</b>	<b>321</b>	<b>330</b>	<b>339</b>	<b>352</b>
<b>Total System Generation (GWh)</b>	<b>829</b>	<b>852</b>	<b>876</b>	<b>1,015</b>	<b>1,285</b>	<b>1,478</b>	<b>2,120</b>	<b>2,183</b>	<b>2,245</b>	<b>2,335</b>
<b>30 MMscfd Expansion</b>										
HFO	146	180	180	127	127	127	127	116	116	116
Solar	6	6	6	6	6	6	6	6	6	6
Wind	10	10	10	10	10	10	10	10	10	10
Biomass	-	14	14	14	14	14	14	14	14	14
Hydro	-	-	-	-	-	-	165	165	165	165
<b>50 MMscfd Expansion</b>										
HFO	146	180	180	127	127	127	127	116	116	116
Solar	24	24	24	24	24	24	24	24	24	24
Wind	10	40	40	40	40	40	40	40	40	40
Biomass	-	24	24	24	24	24	24	24	24	24
Hydro	-	-	-	-	-	-	-	-	-	-

The 30 and 50 MMscfd expansion plans differ in terms of the renewable capacity added for each scenario. The 30 MMscfd option includes 165 MW of hydropower coming online in 2027 resulting in smaller capacity additions in Solar, Wind, and Biomass than 50 MMscfd option which compensates for no hydropower expansion through increased addition of other renewable generation resources.

The yearly expansion for each of the generating resources through 2035 considered in the Study is based on the Expansion Study. For the generating resource option where the total capacity is below the capacity considered in the Expansion Study, the shortfall is covered by additional HFO capacity. For the years past 2035, any generation and capacity shortfall is expected to be covered by HFO based generation.

The expansion for each option is presented in the table below:

**Table 9.3: Generation Options Expansion**

30 MMSCFD Expansion Plan (All units in MW)	2023	2024	2025	2026	2027	2028	2029	2030	2035
SGT400 SC	108	108	108	108	108	108	108	108	108
SGT400 CC	109	140	155	155	155	155	155	155	155
LM2500 SC	127	127	127	127	127	127	127	127	127
LM2500 CC	120	150	180	180	180	180	180	180	180
Wartsila	119	153	153	153	153	153	153	153	153

50 MMSCFD Expansion Plan (All units in MW)	2023	2024	2025	2026	2027	2028	2029	2030	2035
SGT400 SC	108	130	173	194	194	194	194	194	194
SGT400 CC	109	140	171	202	233	264	264	264	279
LM2500 SC	106	127	170	212	212	212	212	212	212
LM2500 CC	120	150	180	210	240	270	270	270	300
Wartsila	102	136	170	204	238	255	255	255	255

To estimate the expected generation from each resource and the particular gas power option, K&M conducted a detailed hourly dispatch for the forecast period. The dispatch methodology consisted of the following steps

- Step 1: The hourly load values for 2017 included several hours with 0 (zero) load due to system blackouts. For our analysis, we adjusted the hourly load in our forecast by replacing the blackout hours with averages of the day before and after.
- Step 2: The hourly load values were forecasted using the demand growth percentage provided in the Expansion Study through 2035 and extended through to 2047 using the method described in the previous section. The forecast from 2036 to 2047 is used to extend the economic evaluation past 2035 and is not based on an economic demand analysis (as done in the Expansion Study)
- Step 3: Once the hourly system load values were forecasted, the dispatch was forecasted with the assumption that renewables (wind, solar, and biomass) are dispatched first, hydropower (for options it is available) is dispatched next, followed by the new gas plant, and HFO is used to dispatch against whatever demand is left. The new power plant availability was assumed at 92%. The wind and solar generation were projected for each hour using NREL's (National Renewable Energy Laboratory) SAM (System Advisor Model) software.

### 9.1.2 Assumptions

The main technical assumptions on the options including size of units, fuel consumption/unit, heat rate, CAPEX, and O&M are described in Section 7 (summarized in Table 9.1). The generation for

each of these options is based on the dispatch criteria mentioned above and an availability factor of 92%. The remaining assumptions used in the analysis are provided in Table 9.4

**Table 9.4: Assumptions**

Assumptions	Value	Units	Source
<b>Technical</b>			
Reserve Margin Requirement	Higher of 15% or 2 times the size of the largest units	%	Expansion Study and GPL current practice
New Plant Capacity, 30 MMSCFD	Maximum possible based on available gas quantities	MW	Expansion Study and K&M heat and material balances
New Plant Capacity, 50 MMSCFD	Maximum possible based on available gas quantities	MW	Expansion Study and K&M heat and material balances
<b>Commercial and Financial</b>			
Discount Rate (nominal)	12%	%	IADB
Year 1 Natural Gas Cost	4.7	US\$/MMBTU	Expansion Study
Year 1 HFO Cost	8.3	US\$/MMBTU	Expansion Study
CAPEX for additional generation	1,800	US\$/kW	K&M Assumption
<b>Cost Assumptions</b>			
Cost per kWh, Hydro	0.09	US\$/kWh	Expansion Study
Cost per kWh, Solar	0.08	US\$/kWh	Expansion Study
Cost per kWh, Wind	0.07	US\$/kWh	Expansion Study
Cost per kWh, Biomass	0.05	US\$/kWh	Expansion Study

## 9.2 Summary of Results

The Summary of total costs and LCOE for each option and scenario is presented in Table 9.5 below. Costs are expressed in Present Value over the 28-year forecast period (2020-2047) and as an average unit price of electricity (LCOE) over the period.

**Table 9.5: Cost Comparison of Power Supply Options**

	Capex (US\$ million)	PV (Total Costs) (US\$ million)	Unit Cost of Electricity (US\$/MWh)
<b>30 MMscfd</b>			
SGT400 SC	165	1,150	83.84
SGT400 CC	287	1,056	76.99
LM2500 SC	160	1,080	78.72
<b>LM2500 CC</b>	<b>277</b>	<b>1,019</b>	<b>74.22</b>

	Capex (US\$ million)	PV (Total Costs) (US\$ million)	Unit Cost of Electricity (US\$/MWh)
Wartsila	148	1,030	75.05
<b>50 MMscfd</b>			
SGT400 SC	297	1,148	83.69
SGT400 CC	374	1,059	82.78
LM2500 SC	267	1,136	77.14
LM2500 CC	326	1,006	73.33
<b>Wartsila</b>	<b>198</b>	<b>1,001</b>	<b>72.96</b>

**Figure 9.1: Cost Ranking of Power Options (Unit Cost of Electricity, LCOE-US\$/MWh)**

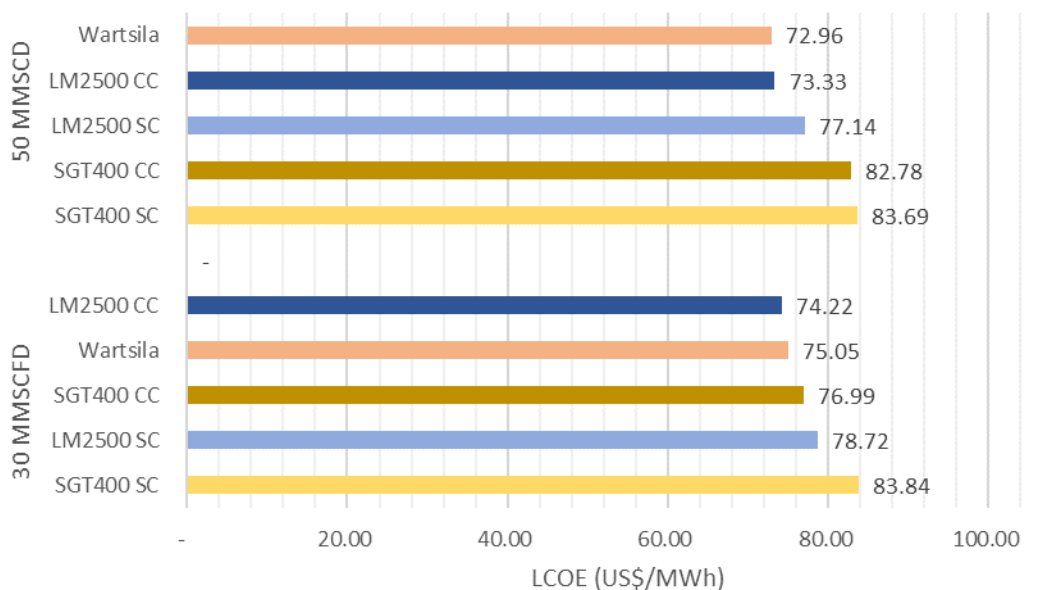

The major observations from our analysis are listed below:

- LCOEs for the 50 MMscfd scenario are lower than for the 30 MMscfd scenario for most of the options. This can be explained by higher generation on lower cost Natural Gas for the 50 MMscfd scenario. However, the difference is relatively small.
- Wartsila and the LM2500 combined cycle are the two least cost options for 50 MMscfd and 30 MMscfd gas supply scenarios, respectively.

The LM2500 CC has the lowest LCOE of US\$74.22/MWh for the 30 MMscfd scenario even though it has the highest CAPEX of US\$1,517/kW. The LM2500 CC has the lowest LCOE because it has the highest installed capacity of 180 MW than all the other options, which coupled with relatively lower heat rates than simple cycle and Wartsila options result in more efficient utilization of Natural Gas and makes up for the higher upfront investment. The unit system electricity cost for Wartsila engines is a close second to the LM 2500 CC at US\$75.05/MWh.

For the 50 MMscfd gas supply scenario, the Wartsila option results in the lowest system unit cost of electricity at US\$72.96/MWh followed by LM 2500 CC at US\$73.33/MWh. The results for the 50 MMscfd scenario are different from the 30 MMscfd scenario due to the relatively smaller size and CAPEX of Wartsila option compared to the LM 2500 CC option with similar generation profiles.

### 9.2.1 LCOE summary for 60 MW PV Solar Penetration Scenario

Based on the information collected during the Inception Mission, it appears that the solar capacity to be added to the GPL system will exceed the forecasted solar capacity in the Expansion Study. To address this development, K&M also conducted the analysis on scenario with increased PV Solar penetration on the total system unit cost of electricity and the results are presented in Figure 9.2.

**Figure 9.2: Cost Ranking of Power Options (Unit Cost of Electricity, LCOE - US\$/MWh). 60 MW PV Solar Penetration**

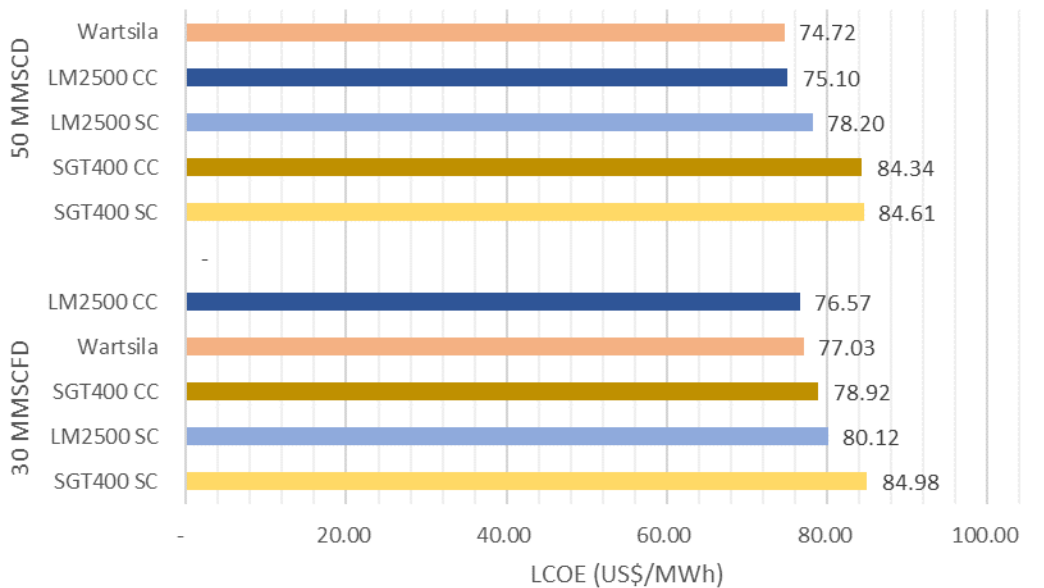

As discussed in Section 4.3, the introduction of additional PV Solar capacity reduces the share of HFO and natural gas generation but slightly increases the LCOE across all options. This variation is due to the high assumed unit cost of US\$0.09/kWh for Solar generation (based on the Expansion Study). PV solar prices have been steadily decreasing over the past several years and K&M believes that the unit cost of US\$ 0.09/kWh is higher than the recent cost trends around the world. K&M believes that the true market price for solar electricity in Guyana will be established soon because of the current solar power plant development activities undertaken by the county.

Comparing the LCOEs for different options in Figure 9.1 and Figure 9.2, we can see that the increase in PV Solar capacity to 60 MW has a very minimal impact on the overall system cost for both gas supply scenarios. The system costs for different options in 30 MMscfd and 50 MMscfd gas supply scenario increase by approximately US\$2/MWh and US\$1.5/MWh respectively. For other PV Solar capacities like 30 MW and 90 MW, we can expect minimal variation in system cost numbers.

LM2500 CC and Wartsila still are the best two options for the new gas fired power plant.

### 9.3 Sensitivity Analysis

K&M conducted a sensitivity analysis on the sensitivity of the LCOE of the options with the following variables

- +/- 10% variation in CAPEX
- +/- 10% variation in Fuel Oil Prices
- +/- 10% variation in Natural Gas Prices

#### Variation in CAPEX

The sensitivity of the LCOE for the options was conducted for high (10% increase), base, and low (10% decrease) variations in CAPEX. As shown in the Figure 9.3, changes in CAPEX has a low impact on the unit LCOE of options.

**Figure 9.3: Sensitivity to CAPEX**

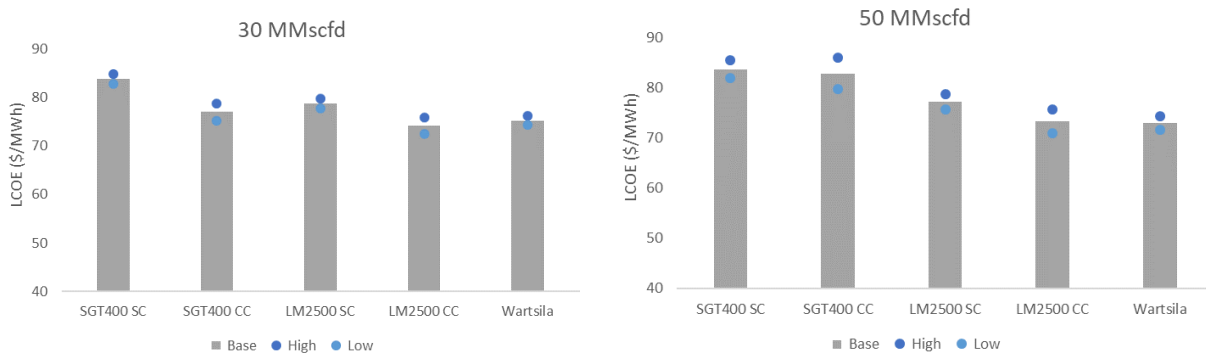

#### Variation in Fuel Oil Prices

The sensitivity of the LCOE for the options was conducted for high case (10% increase), base case, and low case (10% decrease) variations in Fuel Oil prices. We see a moderate impact of variation of Fuel Oil prices on the unit LCOE of the options, see **Figure 9.4**. LM2500 CC becomes the best option for both 30 MMscfd and 50 MMscfd scenarios if the HFO price increases by 10%.

**Figure 9.4: Sensitivity to Fuel Oil Prices**

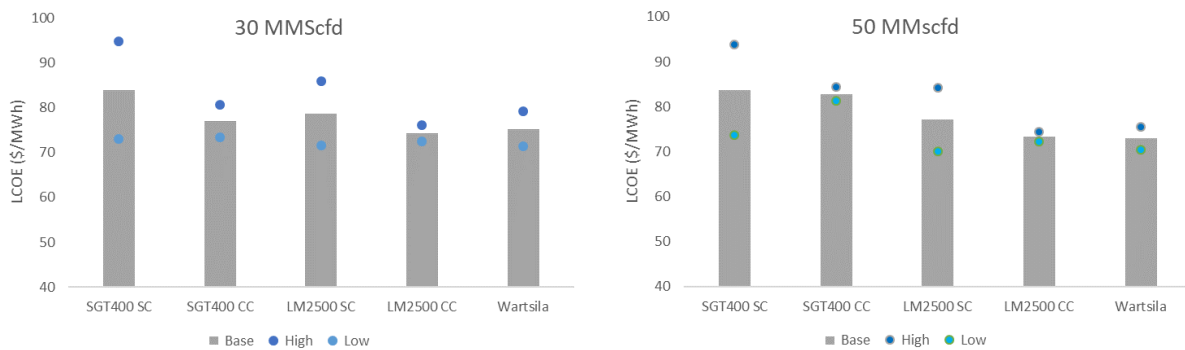

### Variation in Natural Gas Prices

The sensitivity of the LCOE for the options was conducted for high case (10% increase), base case, and low case (10% decrease) variations in natural gas prices. As shown in the Figure 9.5, changes in Natural Gas prices have the largest impact on the unit LCOE of all the variables considered. LM2500 SC option becomes competitive in case of the low natural gas price scenario, especially for 50 MMscfd scenario.

**Figure 9.5: Sensitivity to Natural Gas Price**

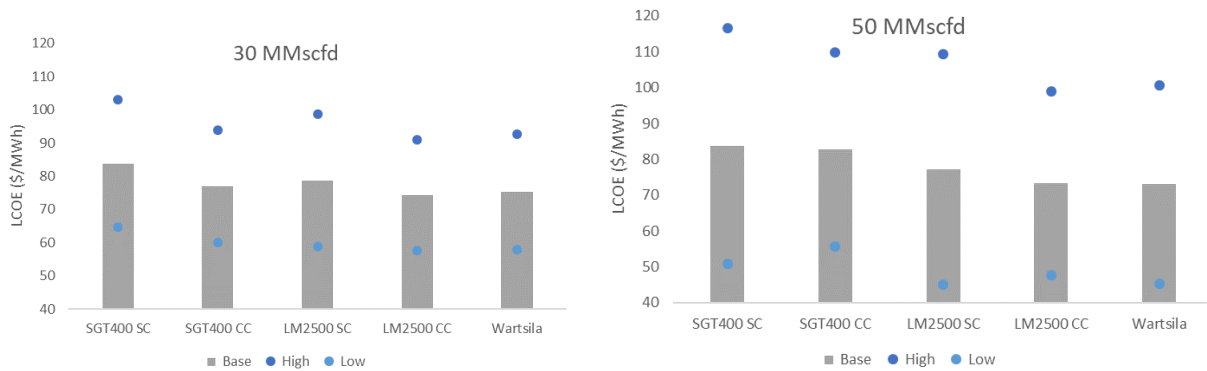

## 9.4 Recommendations

The two best options from our analysis above are LM 2500 Combined Cycle and Wartsila Reciprocating Engines. The pros and cons of the options are presented in the table below:

**Table 9.6: Pros and Cons of LM2500 CC versus Wartsila Reciprocating Engines**

LM 2500 CC	Wartsila Reciprocating Engines
<b>Pros</b>	
Efficient utilization of Natural Gas due to lower heat rate	Lower upfront capital costs
Highest possible capacity for both 30 MMscfd and 50 MMscfd gas supply scenarios	GPL and Guyana's familiarity with the technology.
	Loss of a single unit would not cause a significant strain on the system due to lower unit size of 17 MW
	Ability to run the plant on HFO in case of interruption in the Natural Gas Supply
	Stable heat rate over entire load range
<b>Cons</b>	
Higher reserve capacity requirement due to larger unit size of 30 MW. The loss of a single unit might cause some strain on the system	Higher heat rate at full load than the combined cycle units
Higher upfront capital costs	Lower capacity for the 30 MMscfd scenario



LM 2500 CC	Wartsila Reciprocating Engines
In case of interruption in the Natural Gas Supply, the LM 2500 CC would need the significantly more expensive LFO for operation	
Higher heat rate increase at partial load operation	

Considering the above, K&M recommends Wartsila reciprocating engines as the preferred option for both the 30 MMscfd and 50 MMscfd scenario, since the difference in LCOE for the options is minimal (less than US\$1/MWh) between the two options and using the LM 2500 CC is associated with higher risks.

## 9.5 Expansion Optimization

K&M also conducted a comparative economic analysis on expansion optimization by running different expansion scenarios for the LM 2500 CC and Wartsila (RICE) options for both 30 MMscfd and 50 MMscfd gas supply scenarios. The analysis was done to confirm if the expansion plan presented in the Expansion Study would result in the lowest cost of power generated by GPL.

As discussed in Section 4, the Expansion Study uses a phased expansion of the New Gas Power Plant. An alternative would be to install all or most of the possible New Gas Power Plant capacity in 2023 – around 170 MW for 30 MMscfd or 272 MW for 50 MMscfd. The advantages of installing a larger capacity in 2023 would:

- allow GPL to further reduce its dependence on HFO and generate electricity using cheaper Natural Gas.
- not require engaging the EPC contractor for an extended period of time, resulting in additional savings compared to phased expansion.
- possibly delay the construction and/or reduce the size capital intensive hydro power units.

However, installation of large power plant could result in significant overcapacity and will require a larger amount of upfront capital investment.

K&M considered 4 different expansion scenarios for the LM 2500 CC and Wartsila options which are presented in Table 9.7 below and used present value of costs considering capital, operating, and fuel costs as a comparison criterion:

**Table 9.7: Expansion Scenarios (all units in MW)**

30 MMSCFD - Wartsila (RICE) Option	2023	2024	2025	2026	2027	2028	2029	2030	2035
Expansion Plan (EP)	119	153	153	153	153	153	153	153	153
Modified Plan 1 (MP 1)	153	153	153	153	153	153	153	153	153
Modified Plan 2 (MP 2)	136	136	153	153	153	153	153	153	153
Modified Plan 3 (MP 3)	136	153	153	153	153	153	153	153	153
50 MMSCFD - Wartsila (RICE) Option									
Expansion Plan (EP)	102	136	170	204	238	255	255	255	255

Modified Plan 1 (MP 1)	204	204	204	204	255	255	255	255	255
Modified Plan 2 (MP 2)	102	102	204	204	255	255	255	255	255
Modified Plan 3 (MP 3)	136	136	187	187	238	238	255	255	255
<b>30 MMSCFD - LM2500 CC</b>									
Expansion Plan (EP)	120	150	180	180	180	180	180	180	180
Modified Plan 1 (MP 1)	180	180	180	180	180	180	180	180	180
Modified Plan 2 (MP 2)	90	180	180	180	180	180	180	180	180
Modified Plan 3 (MP 3)	150	180	180	180	180	180	180	180	180
<b>50 MMSCFD - Wartsila (RICE) Option</b>									
Expansion Plan (EP)	120	150	180	210	240	270	270	270	300
Modified Plan 1 (MP 1)	210	210	210	210	300	300	300	300	300
Modified Plan 2 (MP 2)	120	120	240	240	300	300	300	300	300
Modified Plan 3 (MP 3)	150	150	240	240	270	270	300	300	300

The results of the analysis are presented in Figure 9.6 and Figure 9.7 below:

**Figure 9.6: Expansion Optimization Results 30 MMscfd Gas Supply**

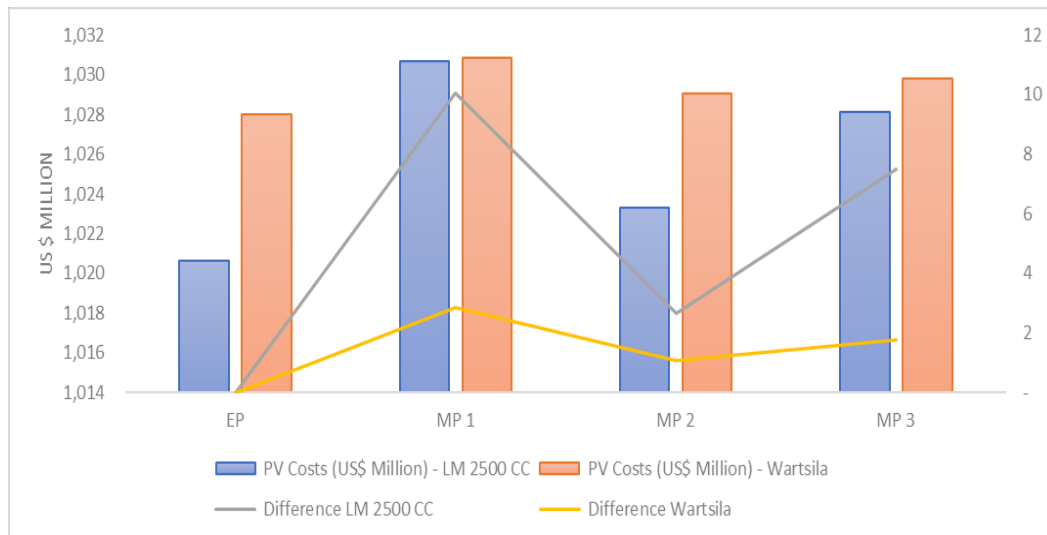

**Figure 9.7: Expansion Optimization 50 MMscfd**

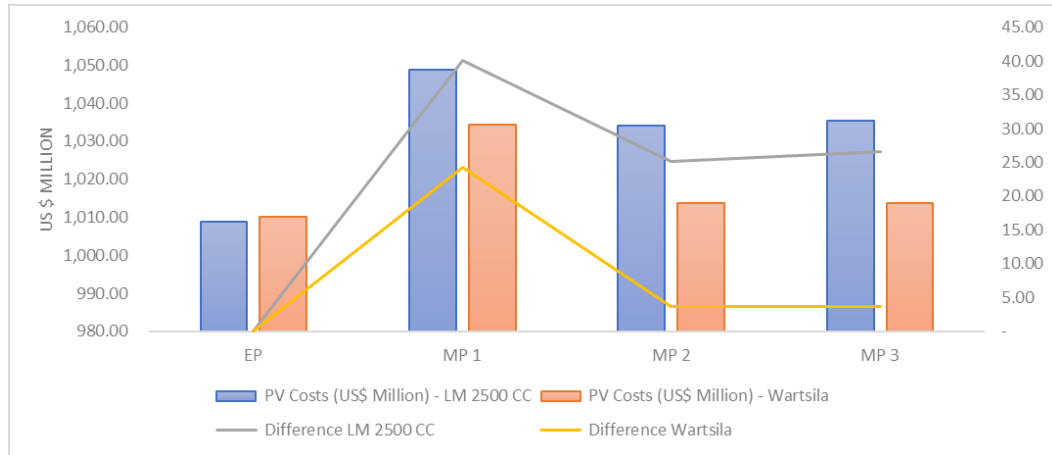

As shown in the above figures, new gas fired power plant expansion in phases based on the Expansion Study results in the lowest cost across both LM 2500 CC and Wartsila options for 30 and 50 MMscfd gas supply scenarios. It is K&M's recommendation that the capacity expansion for the New Gas Plant follow the Expansion laid out in the Expansion Study.

## 10 Emission Reductions and Climate Benefits

---

### 10.1 Emission Reductions

K&M performed an analysis of potential reduction in air emissions expected as a result of generation expansion using Natural Gas versus business-as-usual case of using HFO-fired reciprocating engines. The emission reduction was estimated for two best cases identified in the Cost Benefit Analysis performed in Section 9 of this report for 30 MMscfd and 50 MMscfd Natural Gas availability scenarios

#### 10.1.1 Contaminant air emissions and greenhouse gases

The major contaminants and greenhouse gases generated by burning of fossil fuels at power plants include:

- Nitrogen oxides (NO<sub>x</sub>)
- Sulfur Oxides (SO<sub>x</sub>)
- Carbon Dioxide (CO<sub>2</sub>).

NO<sub>x</sub> is a generic term for the nitrogen oxides that includes nitric oxide (NO), nitrous oxide (N<sub>2</sub>O), and nitrogen dioxide (NO<sub>2</sub>) and is one of the main components of air pollution from fossil-fuel power generation. Similarly, SO<sub>x</sub> is a generic term for sulfur oxides and is the other big component of emissions from power plants. CO<sub>2</sub> emissions do not have as big an impact on the local air quality as NO<sub>x</sub> and SO<sub>x</sub> emissions, but CO<sub>2</sub> emissions have a global impact as it is the primary driver of climate change around the world.

More detailed information on these emission components is presented below.

##### 10.1.1.1 NO<sub>x</sub> – Nitrogen Oxides

NO<sub>x</sub> is the collective term for nitrogenous oxide gases, including NO, NO<sub>2</sub>, N<sub>2</sub>O, and other oxides of nitrogen. The most common NO<sub>x</sub>, nitrogen dioxide (NO<sub>2</sub>), is formed in the ambient air through the oxidation of nitric oxide (NO) and is a highly reactive gas. Nitrous oxide (N<sub>2</sub>O) has a considerable impact on ozone depletion, comparable to that of CFC's, and is considered a greenhouse gas. The formation of NO<sub>x</sub> is a complex process which takes place in the pre-combustion, combustion, and post-flame regions of fossil-fuel generation. It involves the nitrogen found within the combustion air and nitrogen within the fuel itself. High-temperature combustion processes are the major source of man-made NO<sub>x</sub> emissions.

NO<sub>x</sub> contributes to eutrophication, ozone and smog formation, acidification of freshwater bodies, and increases in levels of toxins that are harmful to fish and other aquatic life. Another impact is acid rain which leads to a decrease in the pH-value of rainwater and damages different ecosystems. It also presents a health risk and may lead to changes in airway responsiveness, lung function, other respiratory problems such as asthma and bronchitis, and damages to lung tissue that can cause premature death.

##### 10.1.1.2 SO<sub>x</sub> - Sulfur Oxides

Sulfur oxides are formed when sulfur-containing fuel is burned in the combustion process. During the combustion process sulfur dioxide (SO<sub>2</sub>) is formed, but also a small fraction of sulfur trioxide (SO<sub>3</sub>) is formed with the oxidation of SO<sub>2</sub>.

Sulfur emissions harm the environment through acidification and acid rain particularly around coastal areas and ports. Effects on human health include increased airway resistance, wheezing, shortness of breath, lung cancer, and asthma.

### **10.1.1.3 CO<sub>2</sub> – Carbon dioxide**

Carbon dioxide (CO<sub>2</sub>) is a colorless gas that is produced during the combustion of fossil fuels in reciprocating engines, combustion turbines, and boilers. CO<sub>2</sub> emissions from power generation are highly dependent on the carbon content of the fuel and the fuel consumption. Therefore, the most effective way to reduce emissions is to switch to alternative fuels or more efficient machines.

CO<sub>2</sub> is primary driver of the climate change and global warming as it accounts for about 85% of all greenhouse gases (GHG) released in the US. The second largest source of GHG is methane (CH<sub>4</sub>) which is emitted from agricultural activities and leakage from gas pipelines.

### **10.1.2 Emission Reduction from Switching to Gas**

Compared to HFO, Natural Gas has a lower carbon content and as a result has lower CO<sub>2</sub> emissions. Secondly, Natural Gas does not contain any sulfur, so there are no sulfur emissions from using Natural Gas in power plants. And finally, NO<sub>x</sub> emissions from burning Natural Gas are substantially lower than from HFO. All in all, Natural Gas is a much better option than HFO from an environmental perspective.

K&M estimated the reduction in air emissions resulting from implementing the expansion plan using Natural Gas for the two best technology options for the 30 MMscfd and 50 MMscfd Natural Gas supply scenarios and compared them with business-as-usual option of using HFO-fired reciprocating engines for capacity expansion.

K&M used the methods indicated in the Greenhouse Gas Inventory Guidance - Direct Emissions from Stationary Combustion Sources issued by United States Environmental Protection Agency to estimate the reduction of emissions and greenhouse gases.

There are two main methods for estimating GHG emissions from stationary combustion sources:

- Direct measurement
- Analysis of fuel input

Direct measurement of emissions is performed for operating plants using a Continuous Emissions Monitoring System (CEMS). Since this study considers future expansion, this method is not applicable. Therefore, K&M's calculations were based on the fuel analysis method for SO<sub>x</sub> and CO<sub>2</sub> and on an assumption that the power plants would operate at the NO<sub>x</sub> emission limits established in the IFC Environmental Health and Safety (EHS) guidelines for Thermal Power Plants<sup>9</sup> for Natural Gas and HFO operation for each of the technologies being considered.

### **NO<sub>x</sub> Emissions**

Annual NO<sub>x</sub> emissions were estimated by: i) calculating the total annual fuel consumption by the power plants for each of the cases considered for this analysis, ii) calculating the total flue gas

---

<sup>9</sup><https://www.ifc.org/wps/wcm/connect/9a362534-bd1b-4f3a-9b42-a870e9b208a8/Thermal+Power+Guideline+2017+clean.pdf?MOD=AJPERES>

volumes, and iii) applying the NOx emission limits specified in the IFC EHS guidelines for Thermal Power Plants for non-degraded airsheds as presented in **Table 10.1**.

**Table 10.1: IFC EHS NOx Emission Limits, mg/Nm<sup>3</sup>**

Technology	Gas Turbines	Reciprocating Engines
Natural Gas	50	400
Liquid Fuel	150	740

Source: IFC

### SOx Emissions

Annual SOx emissions for the business-as-usual case of HFO-fired reciprocating engines were calculated by estimating the annual amount of HFO used to generate the electricity that would otherwise be generated on Natural Gas and calculating the total SOx emissions as SO<sub>2</sub> assuming HFO sulfur content of 2%.

### CO<sub>2</sub> Emissions

CO<sub>2</sub> emissions were calculated based on the U.S. EPA methodology by using default emission factors specified in the Greenhouse Gas Inventory Guidance - Direct Emissions from Stationary Combustion Sources issued by EPA and applying that carbon content to the amount of fuel burned to quantify CO<sub>2</sub> emissions.

## 10.2 Summary of Results

For this analysis, it was assumed that the business-as-usual case would use RICE units of the same model of currently operating in Guyana (Wartsila 20V32) using HFO to cover the forecasted demand. The business-as-usual case was then compared to the two best gas fired technology options that include LM2500 GTCC and Wartsila 18V5DF. The estimate assumes base load HHV heat rate for all technologies, including 8,500 BTU/kWh for the existing units.

Table 10.2 and Table 10.3 below summarizes the estimated total emission and emission reductions, expressed in metric tonnes, expected during the period from 2023 to 2035 due to using Natural Gas instead of HFO for expansion of generating capacity in Guyana.

**Table 10.2: Total Emissions and Emission Reduction 2023-2035 (30 MMSCFD)**

Technology	NOx Tonnes	SO <sub>2</sub> Tonnes	CO <sub>2</sub> Tonnes
<b>Emissions</b>			
Existing RICE units burning HFO	88,213	208,334	15,641,957
LM2500 CCGT	5,648	2,956	6,136,744
Wartsila 18V50DF	30,572	10,335	6,963,335
<b>Emission Reduction</b>			
LM2500 CCGT Emission Reduction	82,565 (94%)	205,378 (99%)	9,505,213 (61%)
Wartsila 18V50DF Emission Reduction	57,642 (65%)	197,998 (95%)	8,678,623 (55%)

Source: K&M estimate

**Table 10.3: Total Emissions and Emission Reduction 2023 -2035 (50 MMSCFD)**

Technology	NOx Tonnes	SO2 Tonnes	CO2 Tonnes
<b>Emissions</b>			
Existing RICE units burning HFO	88,213	208,334	15,641,957
LM2500 CCGT	6,962	1,738	8,506,070
Wartsila 18V50DF	41,407	7,949	9,582,047
<b>Emission Reduction</b>			
LM2500 CCGT Emission Reduction	81,973 (92%)	206,596 (99%)	7,135,888 (46%)
Wartsila 18V50DF Emission Reduction	46,807 (53%)	200,385 (96%)	6,059,911 (39%)

Source: K&M estimate

### 10.3 Climate benefits

Natural gas is the cleanest of all the fossil fuels. Composed primarily of methane, the main products of the combustion of Natural Gas are carbon dioxide and water vapor, the same compounds exhaled while breathing. Fuel oils are composed of much more complex molecules, with a higher carbon, nitrogen, and sulfur contents. This means that when combusted, fuel oils release higher levels of harmful emissions, including a higher ratio of carbon emissions, nitrogen oxides (NOx), and sulfur dioxide (SO<sub>2</sub>). Fuel oil also release particulate matter into the environment, substances that do not burn but instead are carried into the atmosphere and contribute to pollution. The combustion of Natural Gas, on the other hand, releases no sulfur dioxide, lower quantities of nitrogen oxides, virtually no ash or particulate matter, and lower levels of carbon dioxide, carbon monoxide, and other reactive hydrocarbons.

Carbon dioxide, one of the major greenhouse gases (GHG) under the UN Framework Convention for Climate Change, is emitted from the combustion of fossil fuels. Recommendations to avoid, minimize, and offset emissions of carbon dioxide from new and existing thermal power plants include, among others, the use of less carbon intensive fossil fuels (i.e., less carbon per unit of calorific value) like Natural Gas which has lower carbon intensity than other fossil fuels like HFO and coal.

Switching from heavy fuel oil (HFO) to Natural Gas, will reduce CO<sub>2</sub> emissions from power generation, due to the lesser carbon content of Natural Gas. NOx and SOx emissions will also be reduced substantially. The emissions will also be impacted by the fact that new gas fired power plant is expected to have better efficiency, thus reducing the overall total fuel consumption.

According to the United States Environmental Protection Agency (EPA), the greenhouse gases that should be considered for calculating the greenhouse gas emissions when burning fossil fuels include carbon dioxide (CO<sub>2</sub>), methane (CH<sub>4</sub>), and nitrous oxide (N<sub>2</sub>O). The amounts of CO<sub>2</sub>, CH<sub>4</sub>, and N<sub>2</sub>O (in tonnes) were calculated by using the formula and emission factors indicated by the U.S. EPA Greenhouse Gas Inventory Guidance<sup>10</sup>:

<sup>10</sup> Federal Register EPA; 40 CFR Part 98; e-CFR, June 13, 2017 (see link below). Table C-1, Table C-2, Table AA-1.

[https://www.ecfr.gov/cgi-bin/text-idx?SID=ae265d7d6f98ec86fcd8640b9793a3f6&mc=true&node=pt40.23.98&rgn=div5#ap40.23.98\\_19.1](https://www.ecfr.gov/cgi-bin/text-idx?SID=ae265d7d6f98ec86fcd8640b9793a3f6&mc=true&node=pt40.23.98&rgn=div5#ap40.23.98_19.1)

$$\text{Emissions} = \text{Fuel} \times \text{HHV} \times \text{EF}_2$$

Where:

Emissions = Mass of CO<sub>2</sub>, CH<sub>4</sub>, or N<sub>2</sub>O emitted

Fuel = Mass or volume of fuel combusted

HHV = Fuel heat content (higher heating value), in units of energy per mass or volume of fuel

EF<sub>2</sub> = CO<sub>2</sub>, CH<sub>4</sub>, or N<sub>2</sub>O emission factor per energy unit.

The calculated emissions of CH<sub>4</sub> and N<sub>2</sub>O were converted to CO<sub>2</sub>-equivalent emissions by multiplying each of the emission values by the respective global warming potential (GWP) factor. The GWPs are specified by the Intergovernmental Panel on Climate Change (IPCC), Fourth Assessment Report (AR4), 2007 at 25 for CH<sub>4</sub> and 298 for N<sub>2</sub>O.

The CO<sub>2</sub> equivalent emissions from CH<sub>4</sub> and N<sub>2</sub>O were added to the emissions of CO<sub>2</sub> to calculate the total CO<sub>2</sub>-equivalent (CO<sub>2</sub>e) emissions.

To quantify the economic impact of greenhouse emissions, the calculated CO<sub>2</sub>-e values were multiplied by \$21.41, the carbon credit value on EU ETS (emission trading system) of as of October 1, 2018<sup>11</sup>.

The values in Table 10.4 and Table 10.5 below were calculated as described above and are used to estimate the quantitative impact of emission reduction using the total carbon credit market value during the period from 2023 to 2035.

**Table 10.4: Carbon Credits Estimate for CO<sub>2</sub>e Reduction (30 MMSFD case)**

Technology	Tonnes of CO <sub>2</sub> e	Tonnes of CO <sub>2</sub> e reduced	Carbon Credit Value, USD
Existing Wartsila HFO	15,694,819	0	\$0
LM2500 CCGT	6,143,603	9,551,216 (61%)	\$234,100,305
Wartsila 18V50DF	6,972,347	8,722,472 (56%)	\$213,787,786

Source: K&M estimate

**Table 10.5: Carbon credits estimate for CO<sub>2</sub>e reduction (50 MMSCFD case)**

Technology	Tonnes of CO <sub>2</sub> e	Tonnes of CO <sub>2</sub> e reduced	Carbon Credit Value, USD
Existing Wartsila HFO	15,694,819	0	\$0
LM2500 CCGT	8,515,161	7,179,658 (46%)	\$175,973,425
Wartsila 18V50DF	9,593,344	6,101,476 (39%)	\$149,547,174

Source: K&M estimate

To estimate economic benefits associated with reduction in NO<sub>x</sub> and SO<sub>2</sub> emissions, K&M used a methodology recommended by the World Bank which estimates the health damage costs from

<sup>11</sup> <https://sandbag.org.uk/carbon-price-viewer/>



air pollution. The damage costs are estimated per ton of emissions per million of affected population and per capita GDP and take into account the approximate height at which emissions are released<sup>12</sup>. As indicated in Table 10.2 and Table 10.3, the estimated emissions of NOx and SO<sub>2</sub> for the BAU scenario are 88,213 and 208,334, respectively. The results of NOx and SO<sub>2</sub> emission reduction estimate and associated economic benefit during the period from 2023 to 2035 are presented in Table 10.6.

**Table 10.6: Cost of SOx and NOx reduction**

Scenario	Tonnes of NOx reduced vs. BAU	Value, USD	Tons of SOx reduced vs. BAU	Value, USD	Total Value (SOx+NOx) USD
LM2500 CCGT 30 MMSCFD	82,565	\$18,381,729	205,378	\$61,621,647	<b>\$80,003,376</b>
Wartsila 18V50DF 30 MMSCFD	57,642	\$12,832,901	197,998	\$58,573,233	<b>\$71,406,134</b>
LM2500 CCGT 50 MMSCFD	81,252	\$18,089,316	206,596	\$61,625,362	<b>\$79,714,678</b>
Wartsila 18V50DF 50 MMSCFD	46,807	\$10,420,659	200,385	\$59,279,101	<b>\$69,699,760</b>

Source: K&M estimate

All the amounts above are expressed in nominal US\$.

<sup>12</sup> Guidelines for Economic Analysis of Power Sector Projects, updated as of September 2015.

## 11 Conceptual Design for Two Best Technology Options

---

This section presents the conceptual design of the new gas fired power plant for two technology options recommended as a result of cost-benefit analysis presented in Section 9 — Wartsila 17 MW dual fuel (natural gas and HFO) reciprocating engines and GE LM2500 combined cycle. For each of the options, the conceptual design is developed for 30 MMscfd and 50 MMscfd supply scenarios.

### 11.1 General Considerations and Assumptions

Section 9 of this report concluded that the two best technology options for the new gas plant are Wartsila RICE and LM 2500 CC power plants. These options were selected based on the technologies' abilities to meet future generating demand at the lowest system cost of electricity under both gas supply scenarios.

Major considerations in determining the number and size of individual generating units and overall capacities for each option included the following:

- The trip of any single unit should result in a loss of capacity less than 10% of system peak load;
- An installed reserve margin should be at least 15% of peak generating capacity or the total capacity of the two largest generating units, whichever is higher.

K&M applied GT Pro/PEACE software to develop the conceptual design. Sizing of the power cycle and balance of plant systems, equipment, and the level of redundancy are consistent with good engineering practices and typical configurations for the selected engines and plant capacities. These determinations were made considering sufficient redundancies as well as overall generic site layout and general arrangement limitations.

Note that GT Pro models for each of the two recommended technology options were prepared under two gas supply scenarios (30 MMscfd and 50 MMscfd) – a total of four cases). Varying generation capacities require different number of units in different configurations. A more detailed description of plant configurations for different engine and gas supply scenarios is presented in Sections 11.2 and 11.3.

Design of new generation interconnected to the GPL system shall meet or exceed the requirement set forth in section 5 of the National Grid Code, Minimum Technical Requirements.

Other assumptions related to gas delivery, generic site preparation, material delivery, water supply, and each specific option are described below.

**Table 11.1: Summary of Key Characteristics of Generating Alternatives**

Parameter	Units	Wartsila 30 MMscfd	RICE 50 MMscfd	LM2500 CC 30 MMscfd	LM2500 CC 50 MMscfd
Number of engines	No	9	15	6	10
Net Plant Output	MW	152.5	254.2	182.6	304.3
Full Load Heat Rate	Btu/kWh	7724	7724	6780	6780
Full Load Efficiency	% (LHV)	44.2%	44.2%	50.3%	50.3%
Hourly Gas Demand at Full Load	MMBtu/hr (LHV)	1178	1963	1238	2063
	MMscfd	1.19	1.98	1.25	2.08
Daily Gas Demand	MMBtu/day (LHV)	28,300	47,100	29,700	49,500
	Scfd	28.6	47.5	30.0	49.9
Approximate Land Requirements for Power Plant	m <sup>2</sup>	24,000	30,000	35,000	54,000
Total Owner's Capital Cost	million USD	164	261	268	429
Normalized Capital Cost	USD / kW	1075	1026	1469	1410

Source: K&M

### 11.1.1 Gas Delivery

It is assumed that, indigenous natural gas reserves from the Stabroek oil field block will be transported through high pressure underwater pipelines to new gas processing facilities at a site adjacent to the new gas-fired power plant. These facilities are not considered a part of the Project. The gas composition supplied to the power plant after processing by the gas treatment facility is expected to have low impurities and condensable components content<sup>13</sup> and therefore, minimal natural gas treatment is expected at the power plant. Any additional natural gas conditioning and heating requirements at the power plant will be determined during detailed design phase based on recommendations of equipment manufacturers.

According to the performance model developed for this project, for the LM2500 combined cycle option 30 MMscfd of natural gas can support a power plant with net capacity of 182.6MW (the required gas flow is approximately 29 MMscfd), while 50 MMscfd can support a plant net capacity of 304.3 MW (the required gas flow is approximately 49.44 MMscfd).

<sup>13</sup> Desk Study of the Options, Cost, Economics, Impacts, and Key Considerations of Transporting and Utilizing Natural Gas from Offshore Guyana for Generation of Electricity. Energy Narrative. June 2017

For the RICE option 30 MMscfd of natural gas can support a plant with net capacity of 152.4 MW (the required gas flow is approximately 28.6 MMscfd), while 50 MMscfd of natural gas can support a power plant with net capacity of 254.2 MW (the required gas flow is approximately 47.5 MMscfd)

According to the preliminary information, natural gas is expected to be delivered to the gas processing plant at a pressure of 1800 psig. There will be pressure loss in the gas processing equipment and the prospective gas supplier assumes that natural gas will be delivered to the power plant at 150 to 200 psig. The LM2500 engines require fuel gas pressure in the 700 psig range. The prospective gas supplier stated that there is a possibility that the fuel gas supply system can be designed to accommodate this pressure requirement. However, the power plant conceptual design prepared for this study assumes that the LM2500 options will include fuel gas compressors as part of the power plant project in case the fuel gas supply is at the lower pressure range. The conceptual designs for the RICE cases do not include fuel gas compression.

### **11.1.2 Power Plant Generic Location**

Based on other experiences and considering that the gas will be transported to shore via a pipeline, it is likely that the selected site will be located close to the coast and since Guyana coast is vulnerable to sea rise effects, shore protection will be required on at least three sides of the plant boundary meaning, the 2 lateral side and the side facing the sea. Therefore, considering the existing sea protection in most of the coastal areas of Guyana and the generic site layout, for the purposes of this report it is assumed that placement of suitable armor stone will be required for approximately 2,650 feet (808 m) along the three sides of perimeter of the plant site. It is assumed that the gas-processing facility will provide their own shore protection system.

Assuming that the site is located in a low laying area near the shore, site remediation is required for an estimated 10,000 m<sup>2</sup> in the 30 MMscfd scenario and 15,000 m<sup>2</sup> in the 50 MMscfd scenario assuming that only part of the required land will require remediation. This remediation is necessary to address the likely flat and low land like conditions of the coastal area. Though there is no geotechnical data available for the coastal areas, based on the previous experience with similar sites it is assumed that site will have to be stabilized by installing wick drains and covering it with minimum of 7 feet of surcharge soil. The conceptual design in this report also assumes that after material settlement, it will be necessary to remove the top two feet to bring the site to final grade. The final grade elevation will have to be established at the detailed design stage based on analysis of bathymetric data for a selected site and considering projected sea level rise of approximately 0.6 m by 2080<sup>14</sup>.

### **11.1.3 Provisions for Equipment, Material, and Backup Fuel Delivery**

Considering the characteristics of the coastal areas of Guyana it is possible that the offshore waters at the site could stay shallow for a very long distance. If this is the case, one of the solutions would be to install a long jetty to allow receipt of equipment, materials or fuel oil from for ocean-going vessels. Such a jetty would be expensive, require a long construction period and could have significant environmental impact. Another solution would be to deliver equipment and materials

---

<sup>14</sup> IPCC, 2014: Climate Change 2014: Impacts, Adaptation, and Vulnerability. Part B: Regional Aspects. Contribution of Working Group II to the Fifth Assessment Report of the Intergovernmental Panel on Climate Change. Chapter 29.

by road. However, the overland road infrastructure in Guyana is poor and the site may not have convenient existing road access.

For the conceptual design purposes K&M assumes that a new barge-unloading facility will be installed adjacent to the site. Dredging, backfilling, and concrete work are required to build this facility, along with construction of a road connecting the power plant and the unloading facility. Equipment and materials would be shipped to Georgetown and off-loaded onto shallow-draft barges for delivery to the site. The cost estimate presented in Section 12 does include the costs associated with construction of the barge unloading facility.

#### **11.1.4 Water Supply**

The LM2500 CC option requires water for steam cycle/cooling makeup whereas the Wartsila RICE option uses water for fire, potable and service systems. The raw water is assumed to be pumped from one of the existing fresh water irrigation canals and will require treatment prior to connecting with the plant piping systems. The vast majority of the water consumed in LM 2500 CC is for cooling tower makeup to replace evaporation and blowdown. Water requirements for the combined cycle option are:

- for 30 MMscfd scenario - 132 lb/s (60 kg/s or 5,185 m<sup>3</sup>/day)
- for 50 MMscfd scenario - 220 lb/s (100 kg/s or 8,640 m<sup>3</sup>/day).

Water requirements are also quantified for each option in the description of conceptual designs in the following section.

Although the Wartsila RICE option requires virtually no cooling water supply to the engines, auxiliary water systems are required that are similar but smaller in size to the ones used in the LM 2500 CC option. Therefore, a raw water pumping station is assumed to be in the same location for Wartsila options, along the fresh water irrigation canal. As stated above, the required quantities of water to RICE option will be minimal and can only be quantified at the detailed design stage.

Note that there is no existing city water piping tie-in assumed to be available for plant water supply.

## **11.2 Wartsila RICE Options**

### **11.2.1 30 MMscfd Scenario**

The 30 MMscfd scenario utilizes nine (9) dual-fuel Wartsila 18V50DF RICE engines, each generating approximately 17MW of power. These units include a closed loop cooling system that requires very minimal external water supply.

The selected RICE engines can burn HFO as well as natural gas. The conceptual design includes one (1) fuel oil tank, one (1) fuel oil unloading pump, two (2) 100% fuel oil forwarding pumps, to supply and transfer HFO to the units.

Other major equipment includes a black start generator, fire tank and pumps, aqueous ammonia tank to serve the Selective Catalytic Reduction (SCR) system, engine/generator lube oil coolers/coolant pumps, air compressors, and a Continuous Emission Monitoring System (CEMS). An SCR system using aqueous ammonia is also included for each RICE engine to reduce Nitrogen Oxide (NO<sub>x</sub>) levels in the exhaust gases.

Power is evacuated from the nine (9) RICE units through three (3) 230 kV step-up transformers and two (2) LV step-down transformers which are located in the adjacent plant switchyard.

Figure 11.1 below shows the results of the GT Pro heat and material balance for this option.

**Figure 11.1: Heat and Material Balance for Wartsila RICE at 30 MMscfd**

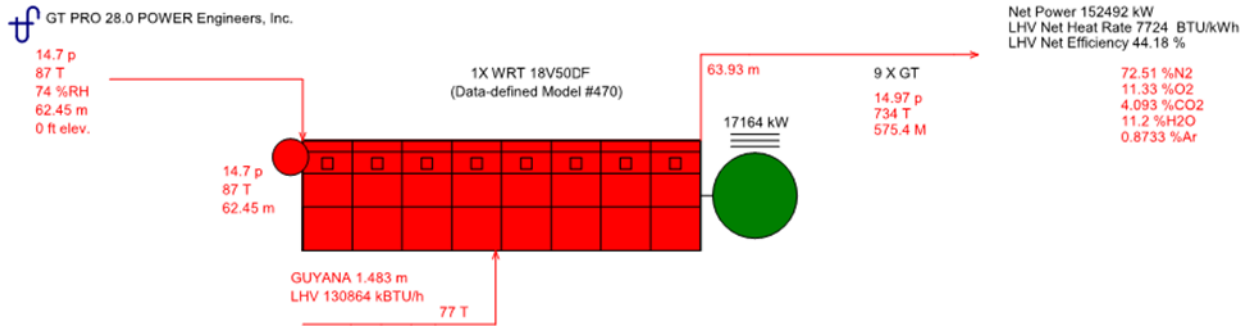

Source: K&M

**Note**

P[psia], T[F], M[lb/s], Steam Properties: IFC-67

**11.2.2 50 MMscfd Scenario**

The 50 MMscfd scenario utilizes fifteen (15) Wartsila 18V50DF RICE engines to meet the larger load requirements under this scenario. This design is based on the same technical and system requirements as described above for the 30 MMscfd case, with higher quantities for some equipment. Power is evacuated from the fifteen (15) RICE units through five (5) 230 kV step-up transformers and four (4) LV step-down transformers.

A larger site footprint is required to accommodate the higher capacity and equipment quantity.

Figure 11.2 below shows the results of the GT Pro heat and material balance for this option.

**Figure 11.2: Heat and Material Balance for Wartsila RICE at 50 MMscfd**

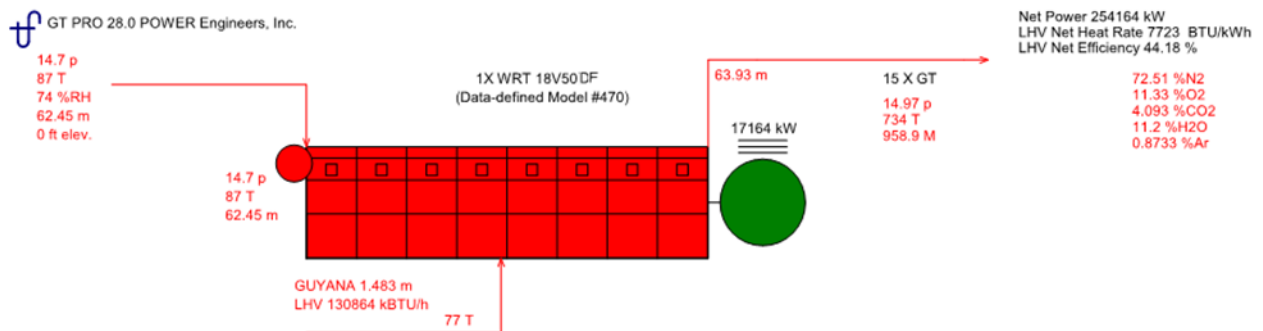

Source: K&M

**Note**

P[psia], T[F], M[lb/s], Steam Properties: IFC-67

## 11.3 LM2500 Combined Cycle Options

### 11.3.1 30 MMscfd Scenario

The 30 MMscfd scenario consists of three separate power islands in a 2-on-1 combined cycle configuration (CCGT). This results in a total of six (6) GE LM2500 gas turbines (GT), six (6) heat recovery steam generators (HRSG), and three (3) steam turbines (ST). Each GT is capable of generating approximately 21.5 MW, while each ST is capable of generating approximately 22.5 MW. Note that the HRSG and ST models have not been selected at this stage (for both supply scenarios) and the GT Pro program used representative data for this equipment.

Each 2-on-1 CCGT power island includes one (1) water-cooled condenser, three (3) x 50% HP/IP boiler feedwater pumps, two (2) x 50% condensate pumps, two (2) condensate forwarding pumps, and two (2) condenser vacuum pumps. The plant requires a total circulating cooling water flow of 4,950 lb/s (2,250 kg/s), and a total makeup water flow of 132 lb/s (60 kg/s) to one (1) common cooling tower.

The GE LM2500 GTs can burn light distillate fuel oil (LFO) as backup to natural gas. Two (2) fuel oil tanks, one (1) fuel oil unloading pump, and two (2) fuel oil forwarding pumps are assumed in GT Pro to supply and transfer LFO to the units.

Other common major plant equipment included in the conceptual design:

- Black start generator.
- Two (2) air compressors.
- Auxiliary heat exchanger.
- Tanks – One (1) Aqueous Ammonia, One (1) Demineralized Water, One (1) Raw Water, One (1) Neutralized Water, One (1) Acid, One (1) Caustic, and One (1) Fire Protection.
- Pumps – One (1) Treated Water, Two (2) Demineralized Water, Three (3) Raw Water, Two (2) Aux Cooling Water (closed), Two (2) Aux Cooling Water (open), One (1) Diesel Fire, and One (1) Jockey Fire.
- Piping, valves, instruments, motors, and CEMS (per GT Pro PEACE).
- Water Treatment Plant.
- SCR for de-NOx

Power is evacuated from nine (9) generators (6 GT and 3 ST) through six (6) 230kV GT step-up transformers, three (3) 230kV ST step-up transformers, one (1) MV step-down transformer, and three (3) LV step-down transformers. All transformers and other major electrical equipment are located in the adjacent plant switchyard for both supply scenarios.

Figure 11.3 below shows the results of the GT Pro heat and material balance for this option.

**Figure 11.3: Heat and Material Balance for LM2500 CC at 30 MMscfd**

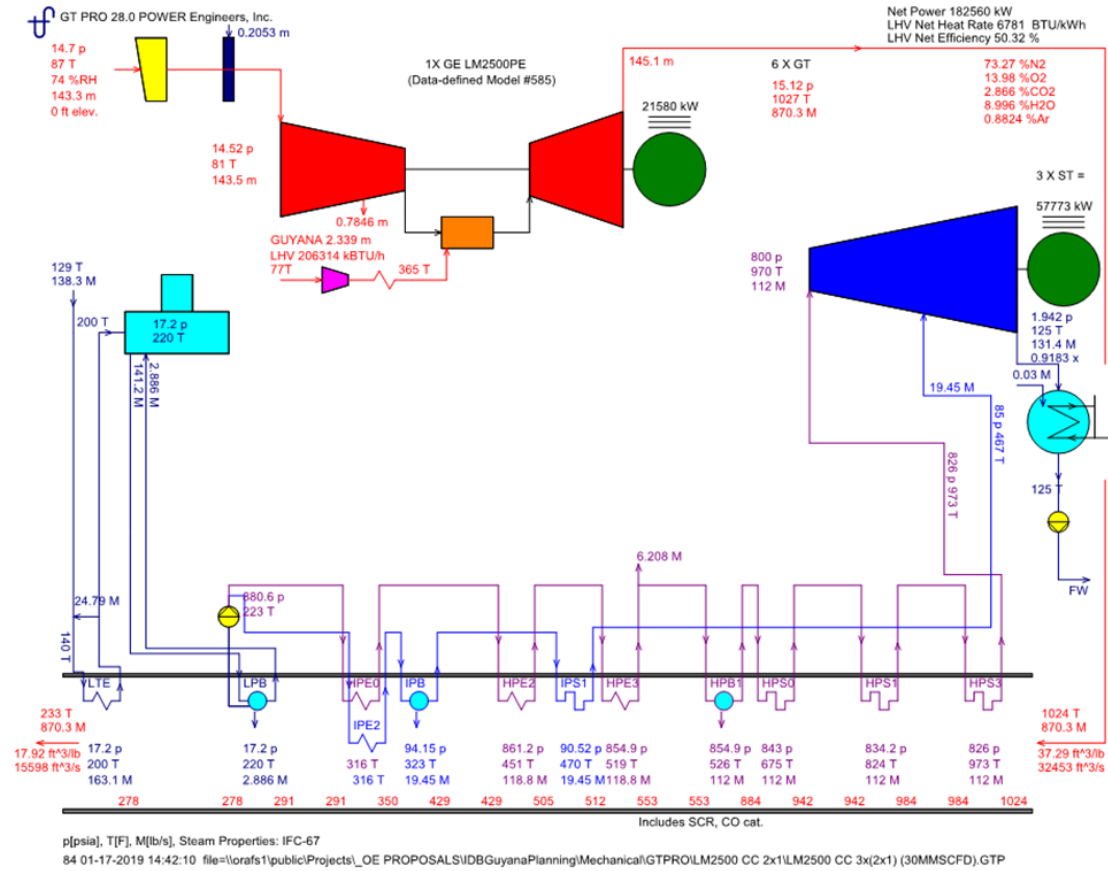

Source: K&M

**Note**

P[psia], T[F], M[lb/s], Steam Properties: IFC-67

**11.3.2 50 MMscfd Scenario**

The 50 MMscfd scenario consists of five separate power islands in a 2-on-1 combined cycle configuration (CCGT). This results in a total of ten (10) GE LM2500 gas turbines (GT), ten (10) heat recovery steam generators (HRSG), and five (5) steam turbines (ST). The generating capacity of each unit in this scenario is the same as 30 MMscfd scenario, as same equipment is used for both designs.

Each 2-on-1 CCGT power island requires the same quantity and configuration of boiler feedwater and condensate equipment as described above. The plant requires a total circulating cooling water flow of 8,250 lb/s (3,750 kg/s), and a total makeup water flow of 220 lb/s (100 kg/s) to one (1) common cooling tower. In terms of fuel oil and other common major equipment, both scenarios require the same equipment quantities, though their sizing may be larger for this scenario due to larger loads.

Power is evacuated from fifteen (15) generators (10 GT and 5 ST) through ten (10) 230kV GT step-up transformers, five (5) 230kV ST step-up transformers, one (1) MV step-down transformer, and five (5) LV step-down transformers per GT Pro.



A larger site footprint is required to accommodate the higher capacity and equipment quantity. Figure 11.4 below shows the results of the GT Pro heat and material balance for this option.

**Figure 11.4: Heat and material Balance for LM2500 CC at 50 MMscfd**

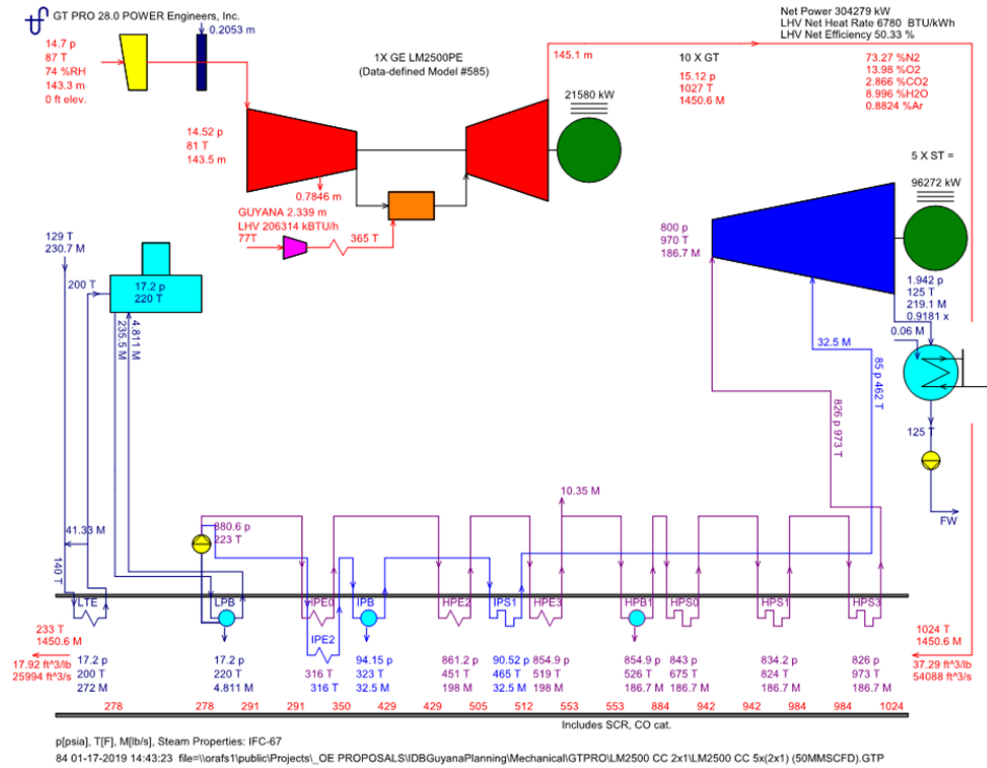

Source: K&M

**Note**

P[psia], T[F], M[lb/s], Steam Properties: IFC-67

## 12 Cost Estimates

---

Cost estimates for the power plant for the two gas supply scenarios were developed for both options – Wartsila 17 MW dual fuel reciprocating engines (RICE) and GE LM2500 combined cycle – using the GT Pro PEACE program for equipment and materials and manual estimates for site preparation and the barge-receiving facility for a generic site located in Guyana coastal area. GT Pro PEACE's methodology utilizes a data base of equipment and material reference costs for standard equipment selection and sizing based on the heat balance flows. Based on the sizing resulting from the heat and material balance calculations the computer program looks up corresponding costs in the cost data base. K&M then applied cost multipliers for different components of the plant to reflect project configuration (for example, plants with multiple units cost less than single unit plants) and country-specific conditions such as, for example, lower labor cost in developing countries compared to the U.S. and European countries.

For the RICE option, the cost estimates were based on using nine (9) engines for the 30 MMscfd scenario, and fifteen (15) engines for the 50 MMscfd scenario. For the combined cycle option, both gas supply scenarios used multiple islands with a 2-on-1 configuration consisting of two (2) gas turbines and one (1) steam turbine per island.

The estimates include site preparation requirements applicable to the assumed generic site which make up part of the "Civil" and "Buildings & Structures" figures below in the summary table. For the purposes of this study it is assumed that site preparation activities include Site Remediation, Shore Protection, and a Barge Unloading Facility. Prior experience along with known project quantities were used to estimate these components. The conceptual design and cost estimates consider the possible climate change impacts such as rising sea level and ambient temperature when evaluating overall capital cost and performance of the new power plant.

As part of developing these cost estimates, the following assumptions were made:

- Three (3) sides for shore protection (2,644 feet total length) were assumed, as the fourth side has an existing sea defense embankment.
- Site remediation assumed 10,000 m<sup>2</sup> area for the 30 MMscfd scenario, and 15,000 m<sup>2</sup> area for the 50 MMscfd scenario.
- Local Guyana labor rate for site work is assumed to be US\$15.00 per hour. This assumption is based on the minimum wage of GYD 66,400 per month adopted in 2019 for public sector employees<sup>15</sup> (this translates to US\$1.85/hr) and assumes that a qualified construction worker in Guyana makes approximately 3 times the minimum wage and that construction contractors charge their customers approximately 2.7 times the direct rate to account for overhead and profit.
- Cost estimate does not include land acquisition and financing costs.

A summary table of costs is included below in Table 12.1, comparing major costs, net plant output, and costs per kW for all scenarios.

---

<sup>15</sup> <https://newsourcegy.com/news/budget-2019-public-sector-minimum-wage-increased-to-64200-per-month/>

**Table 12.1: Summary of Major Costs (all costs in US\$)**

Project Cost Summary		Wartsila 17 MW Dual-Fuel RICE		GE LM2500 Combined Cycle	
		30 MMscfd	50 MMscfd	30 MMscfd	50 MMscfd
I.	Specialized Equipment	80,492,612	132,488,403	129,004,593	214,288,255
II.	Other Equipment	2,039,058	2,928,692	9,624,888	14,741,391
III.	Civil	12,961,491	19,019,454	18,703,642	28,470,371
IV.	Mechanical	7,540,735	12,576,706	13,311,869	23,265,088
V.	Electrical Assembly & Wiring	2,807,528	5,136,472	4,971,196	9,557,983
VI.	Buildings & Structures	17,771,137	20,156,757	14,323,646	14,527,030
VII.	Engineering & Plant Startup	4,247,300	5,604,400	12,047,150	15,833,300
<b>Subtotal – Contractor's Internal Cost</b>		<b>127,859,860</b>	<b>197,910,883</b>	<b>201,986,984</b>	<b>320,683,417</b>
VIII.	Contractor's Soft & Misc. Costs	24,156,012	41,255,279	44,046,589	72,804,716
<b>EPC Contractor's Price</b>		<b>152,015,872</b>	<b>239,166,162</b>	<b>246,033,573</b>	<b>393,488,132</b>
IX.	Owner's Soft & Misc. Costs	11,881,428	21,524,955	22,143,022	35,413,932
<b>Total – Owner's Cost</b>		<b>163,897,300</b>	<b>260,691,117</b>	<b>268,176,594</b>	<b>428,902,064</b>
Net Plant Output (MW)		152.5	254.2	182.6	304.3
<b>Price per kW – EPC Contractor (USD per kW)</b>		<b>997</b>	<b>941</b>	<b>1,348</b>	<b>1,293</b>
<b>Price per kW – Owner (USD per kW)</b>		<b>1,075</b>	<b>1,026</b>	<b>1,469</b>	<b>1,410</b>

Source: K&M

## 13 Financing Options Analysis

K&M considered two methods for financing the Project. The first method is to pursue a GPL corporate financing, such as a long-term balance sheet financing (corporate loans or bonds) and the second method is to pursue a non or limited recourse financing (i.e. "Project Finance"). Corporate Financing is frequently used for projects owned by government owned utilities around the world. Under this method of financing, GPL would have ownership and control of the Project and would select an EPC Contractor to design, procure, and construct the Project and potentially operate the Project during its useful life. Under this approach, GPL will be fully exposed to the Project's development, construction, and operation risks while the Project's capital cost will be reduced due to elimination of a material portion of the "Owner's soft and miscellaneous costs" shown in the previous section. Also, the corporate debt holders would have recourse to the assets of GPL as the corporate borrower.

To secure a Project Financing, the Project would require an experienced and proven independent power producer (IPP) as sponsor establishing a special purpose vehicle (SPV) to be the borrower. As compared to a corporate loan transaction, a Project Financing will typically require, among other things, (i) a more detailed due diligence review, (ii) a more comprehensive risk mitigation plan, (iii) a contract structure and contract provisions which optimally allocate risk among the project participants, and (iv) a robust security package to provide quick and easy access to a project's assets to protect the lenders interests. With this financing option GPL would need to select a qualified IPP to be responsible for the development, financing, design, procurement, construction and operation of the Project during a pre-determined period (usually 20 to 25 years) and purchase capacity and energy generated by the Project under a long term Power Purchase Agreement (PPA). Under this approach, most of the Project development and the entire project construction and operation risk will be assumed by the IPP, but the Project's capital cost will likely be higher than for a Corporate Financing approach by an amount close to the "Owner's soft and miscellaneous costs" shown in Table 2.8 above.

In this Section, K&M analyzes and presents a comparison of implementation of a power project through an IPP concept versus direct procurement by GPL or GoG through an Engineering, Procurement, and Construction (EPC) contract.

### 13.1 Comparison between IPPs versus direct procurement

IPPs are defined as power projects that are,

- 11 Privately developed, constructed, operated, and owned;
- 12 Have a significant proportion of private finance on a non-recourse or limited recourse basis; and
- 13 Have long-term power purchase agreements with a utility or another off-taker.

IPPs can be further differentiated on the following criteria<sup>16</sup>:

<sup>16</sup> Eberhard, Anton, Katharine Gratwick, Elvira Morella, and Pedro Antmann. 2016. Independent Power Projects in Sub-Saharan Africa: Lessons from Five Key Countries. Directions in Development. Washington, DC: World Bank.

- **Ownership and financing structures.** IPPs can be solely owned or joint venture companies with or without minority public funding.
- **Technology.** IPPs could be thermal or renewable energy projects, including diesel, heavy fuel oil, geothermal, hydropower, solar, wind, and biomass. The type of technology dictates certain project agreements like O&M contracts, heat rates, etc.
- **Procurement modalities.** IPP projects can be procured either competitively or directly negotiated (unsolicited). However, most Development Finance Institutions require competitive procurement as a condition of participation
- **Financial and risk mitigation structures.** IPP projects can also employ different risk mitigation, credit enhancement, and security arrangements.

The main advantage of IPPs is their ability to attract private investment on a large scale, particularly from private and multilateral debt markets. The main reason behind this is that in a project financed IPP transaction, the review of project commercial, technical, and regulatory aspects is conducted on a more detailed basis which raises the credit worthiness of a project. The IPPs also have structured legal contracts that appropriately allocate the risks to the different parties.

Table 13.1 below shows the comparison between IPPs versus Procurement through EPC.

**Table 13.1: IPP versus Procurement through EPC**

Item	EPC V. IPP	Advantage
Size	Corporate finance is suitable for smaller projects whereas project finance is best suited for large projects	IPP
Transaction Costs	IPP Projects have generally higher transaction costs. Legal, lender, advisory, are all higher due to contractual nature of an IPP.	EPC
Time to Financial Closing	Corporate finance transactions can be arranged much faster than project finance. These can be concluded in months whereas project finance transactions can take up to a year to conclude (time taken to conclude requisite agreements, applications for any required licenses and/or permits etc.)	EPC
Cost of Debt	Project debt is usually more expensive for IPP than corporate debt.	EPC
Loan Tenor	Corporate lending usually has significantly shortened tenures than project lending. Therefore, the cost of refinancing government loans should be included in the life cycle cost analysis. Tenor may be longer for project financed by governments using DFI loans.	IPP
Discipline	The review, contracting and analysis of the project is performed at a high level for an IPP versus corporate financed project. The detailed review raises the credit quality. Project loans have lower probabilities of default and higher recovery rates than corporate loans.	IPP
Recourse	Project finance provides protection to the sponsor's balance sheet whereas corporate-financed investments expose a sponsoring firm to losses up to the project's total cost, whereas project-financed investment exposes the firm to losses as large as its equity investment.	IPP

Item	EPC V. IPP	Advantage
	Securitization of the financial assets generated by a project does not give financiers recourse against the project's non-financial assets. Giving project lenders priority over the assets of the project helps them to avoid concerns about sharing the benefits of the project with the sponsors' other creditors. This makes it possible to achieve higher levels of leverage than those that are usually seen in conventional corporate finance.	
Management Control	In a corporate financing the assets and cash flows would be governed by existing corporate structures. Project finance lenders strictly govern the sources and uses of funds in great detail, leaving very little to management in the way of discretionary powers.	IPP
Transparency	Single asset nature makes a project's performance transparent. In contrast corporate borrowers often have diverse stream of revenues, complicated subsidiary structures and accounting treatments, and cash flow streams that are difficult to analyze.	IPP

Given the Project capital requirements (US\$ 163 Million to US\$ 429 Million), K&M believes that it may be difficult for GPL to raise the required amounts using a Corporate Finance approach and GPL should pursue a Project Financed based IPP approach to develop this project. However, K&M's financial analysis in this report considers both a Corporate Financed EPC structure and a Project financed IPP structure. A final decision regarding the method of financing to be used for the Project should be made by the GoG and GPL based on economic, financial, and policy considerations after thoroughly considering both Corporate Finance (EPC procurement) and Project Finance (IPP procurement) options.

A typical IPP structure and EPC structure for the new gas plant is provided in the figures below:

**Figure 13.1: Typical IPP Structure**

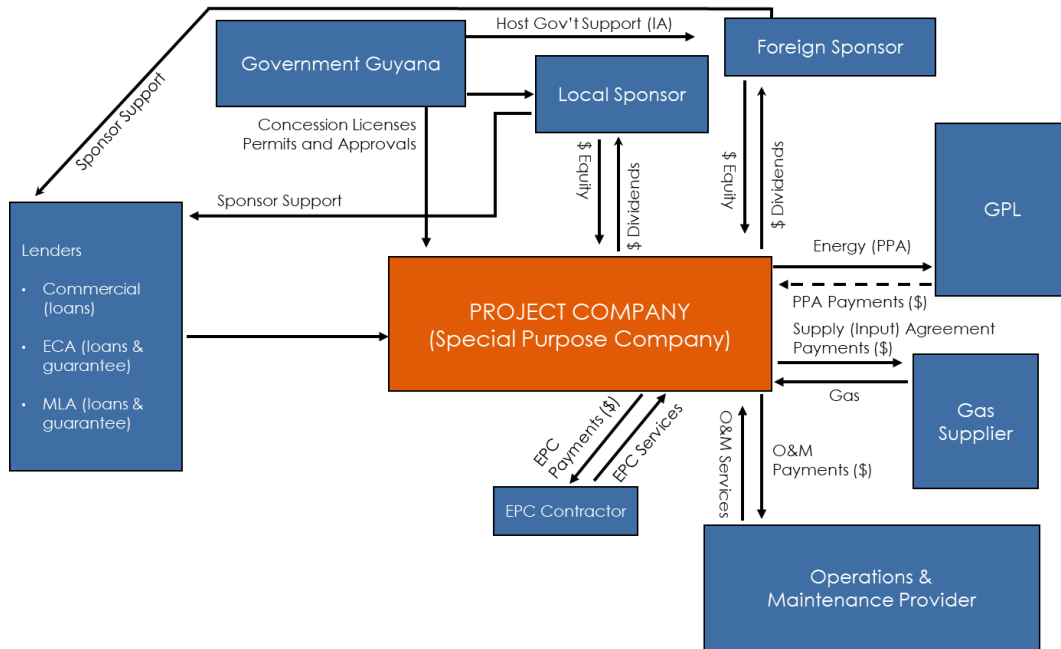

**Figure 13.2: Typical EPC structure**

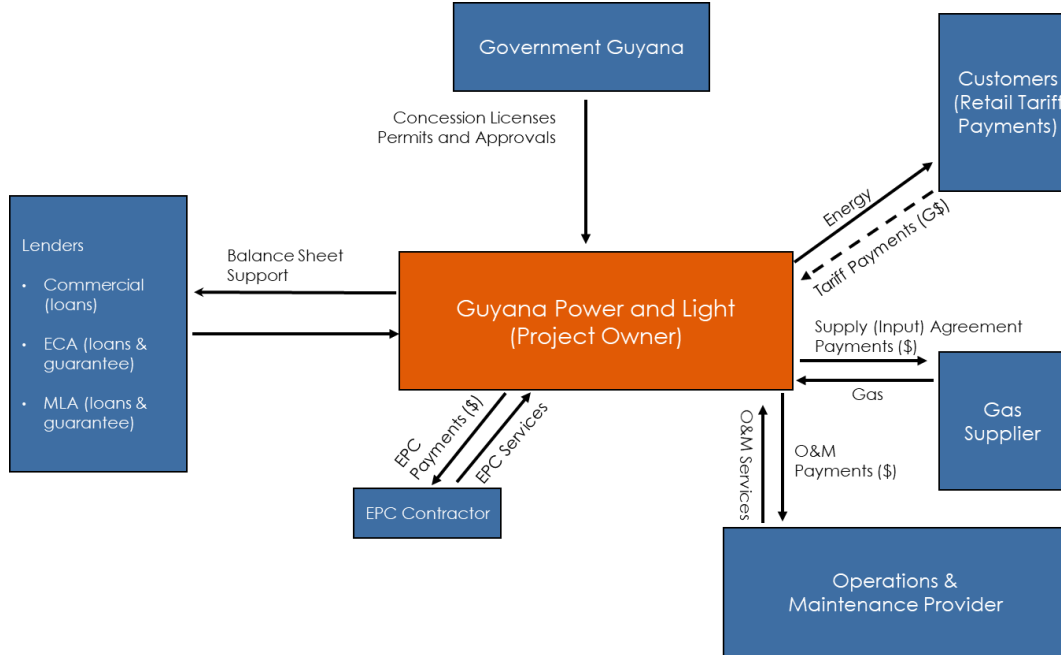

## 13.2 Potential Sources of Equity and Debt Finance

The proposed project will likely be financed through a blend of both equity and debt available from Guyana, the Caribbean, and other foreign countries. Depending upon the requirements of individual lending institutions and their perceptions of risks associated with this project, it could be expected that the Project will likely require a minimum of 20% to 30% equity, with the remaining 70-80% of the finance coming from various sources of limited recourse debt financing.

### 13.2.1 Sources of Equity Financing

In case the Project is developed as an IPP, there are several potential sources of equity for the new power project that the project's private Sponsors might be expected to access. These sources would typically include:

- The Sponsor's own equity capital,
- Multi-lateral sources such as the International Finance Corporation or IDB Invest,
- International equity markets,
- Regional and international investment funds,
- Major project participants (i.e. Operator, EPC contractor),
- The GoG and/or a host of official lending and aid agencies (if the project is a joint venture between the private and public sector), and/or
- Private corporations and/or individuals.

Equity funding should principally come from the Sponsor; however, the Project Request for Proposal (RFP) can allow for contributions from strategic and financial equity investors via a syndicated equity pool. Typically, the senior equity contributor, the Project Sponsor, will invest at least one-third of the equity portion of the investment. It is not uncommon to see the Sponsor invest the entire equity requirement for the Project. The Project Sponsor is under no obligation to split the equity portion of the Project amongst other investors, though it may decide that there are distinct advantages in doing so. For example, in many countries it is strategically advisable to seek local in-country partners/investors to facilitate the process of developing the project.

In case of Corporate Finance (EPC procurement) equity would have to come from either GPL's balance sheet or provided by the Government of Guyana.

### 13.2.2 Sources of Debt Financing

There are also several categories of possible sources of debt that might be expected to be accessed for the New Gas Project developed as an IPP. These categories of debt include:

- Multi-lateral Development Finance Institutions (DFIs)
- Bi-lateral loans,
- Export credit agencies (ECAs),
- International commercial banks,
- International bond markets,
- Regional banks, and/or



- Supplier's credits.

The most likely composition of debt financing will come from several of the financing sources listed above. The final capital and financial structure being proposed for the project will ultimately depend upon the comfort of commercial financial institutions with the perceived commercial, political, and operational risks associated with the project. Depending on the financial health of GPL or GoG, it is likely that multi-lateral, bi-lateral, and/or ECA loans and/or risk and credit enhancements would be needed to de-risk and attract sufficient financing for this project. Generally, multi-lateral DFIs offer longer tenors (12 – 18, and in some cases up to 25 years) and better terms than commercial banks.

In case of Corporate finance, the sources of debt would be similar to the IPP finance with the exception of IFC and OPIC, which typically only participate in privately financed transactions, and addition of the World Bank, which provides financing for the projects sponsored by governments or government-owned entities.

According to the information provided by the Ministry of Public Infrastructure of Guyana, in case the Government of Guyana would be willing to provide sovereign loan guarantee under the EPC structure, the terms of the loan provided for the project by DFIs could be the most beneficial with the interest rate as low as 3.5% and loan tenor of up to 25 years. The financial analysis for the ECA option includes this most beneficial case with the interest rate of 3.5% and loan tenor of 25 years.

## 14 Financial and Economic Analysis

In this section K&M calculated the annual tariff required to achieve a 15% equity IRR under base case technical and financial assumptions for the two different Wartsila and LM2500 CC options. K&M developed a financial model to calculate the tariff and used the cost estimates provided in Section 12. The target IRR of 15% is a typical return sought by private investors for this type of projects in developing countries. Of course, the target IRR will be different for different developers depending on their perception of the project risks.

Sections 14.1 and 14.2 discuss the methodology and results of the financial analysis. Section 14.3 explains the tariff construction and results for the different options, Section 14.4 discusses the LCCA and LCOE, and Section 14.5 analyzes the project sensitivity against different variables.

### 14.1 Model structure and methodology

Figure 14.1 illustrates the structure of K&M's MS Excel financial model used in this analysis. Each box represents a worksheet (or tab) in the model.

Figure 14.1: Model Structure

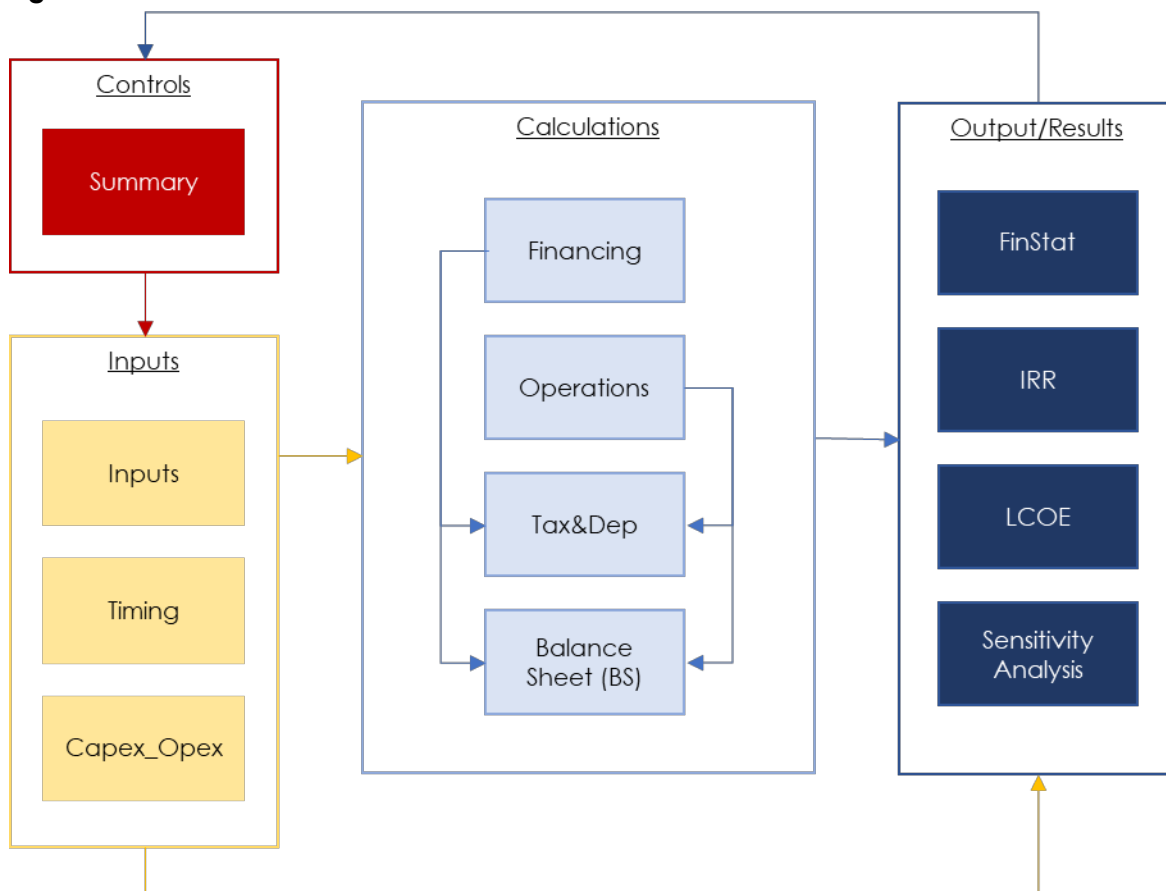

The model is organized according to four main worksheet types: controls, inputs, calculations, and outputs/results. Control worksheets are used to control the main assumptions and analysis. Inputs

contain all the assumptions which drive the model. Calculation worksheets are used to perform the majority of the model's calculations. The Outputs/Results worksheets produce the finished calculations and values which are the results of the model and financial analysis.

### Control Worksheets

- **Summary:** Includes controls and main inputs that run the financial model, also includes summary graphs and results of the financial analysis

### Inputs Worksheets

- **CAPX\_OPEX:** Input and breakdown of CAPEX and O&M. These inputs flow through the investment sections and calculation of financial statements, tariff calculation, and rates of return.
- **Inputs:** This is the source of all inputs/assumptions not listed in other input worksheets.
- **Timing:** This is the source of all major timing flags and counters which determine when revenues and costs occur over the modeling period.

### Calculation Worksheets

- **Financing:** Allocates investment costs between debt and equity for use in calculating LCOE and rates of return.
- **Operations:** Forecasts annual generation, revenues, and operating costs over the Project operations period.
- **Tax and Depreciation (Tax&Dep):** Calculates depreciation (both book and tax. Book depreciation flows through the financial statements and tax depreciation is used to calculate net cash flow, LCOE, and rates of return.
- **Balance Sheet (BS):** This sheet performs balance sheet calculations for the Financial Statements.

### Results Worksheets

- **LCOE:** This worksheet calculates the results of the Life Cycle Cost Analysis and Levelized Cost of Electricity.
- **IRR:** This tab calculates equity IRRs for the Project.
- **Financial Statements (FinStat):** Forecasts Balance Sheet, Cash Flow Statement, and Profit & Loss Statements for the Project.
- **Sensitivity Analysis:** Results of sensitivities against different project variables.

## 14.2 Base case scenario and results

K&M conducted the financial analysis using a Base Case set of assumptions. The major elements of the Base Case include technical configuration, commercial and financial, and tariff.

**Technical Configuration:** The Base Case scenario uses the Base Case Design for the different options as described in Section 11 of this report. The generation output is based on the results of the dispatch analysis that was conducted as part of Section 4.2. The annual generation for different options is included in Appendix E. The Base Case assumes project operating life of 25 years.

The model assumes that the different options will be implemented in a phased approach (as described in Section 4) with each phase adding single or multiple units of the same technology. It is assumed that the first phase will be constructed in 3 years and each subsequent addition will take 2 years as most of the site preparation, environmental, and regulatory work would be completed with the first phase. It should be noted that 3 years represents the time period required to construct the project after financial close and is different from the total project implementation period that includes both project development up to financial close and the 3- year construction period. The phased expansion for different options is provided below (the dates in Table 14.1 and Table 14.2 are the dates when the phases become operational):

**Table 14.1: 30 MMscfd Scenario Expansion Phases**

30 MMSCFD Expansion Plan (all units in MW)	2023 (Phase 1)	2024 (Phase 2)	2025 (Phase 3)
LM2500 CC (30 MW units)	120 (4 units)	30 (1 unit)	30 (1 unit)
Wartsila (17 MW units)	119 (7 units)	34 (2 units)	

**Table 14.2: 50 MMscfd Scenario Expansion Phases**

50 MMSCFD Expansion Plan (All units in MW)	2023 (phase 1)	2024 (Phase 2)	2025 (Phase 3)	2026 (Phase 4)	2027 (Phase 5)	2028 (Phase 6)	2033 (Phase 7)
LM2500 CC (30 MW units)	120 (4 units)	30 (1 unit)	30 (1 unit)	30 (1 unit)	30 (1 unit)	30 (1 unit)	30 (1 unit)
Wartsila (17 MW units)	102 (6 units)	34 (2 unit)	34 (2 unit)	34 (2 unit)	34 (2 unit)	17 (1 unit)	

**Commercial and Financial:** The Project is assumed to have a commercial structure under which all revenues are derived from the sale of electricity to GPL for the IPP or to GPL's customers for a corporate financed approach. The Project is not designed to require any direct subsidy from the Government to supplement its revenues. The main commercial assumptions used are:

- Leverage Ratio: 70%
- Loan interest rate: 3.5% per year for IPP (assuming DFI financing) and EPC option with sovereign guarantee and DFI financing (based on past GPL projects); 8% for EPC option with commercial bank financing.
- Required return on equity: 15% (typical for IPPs in developing countries) and 8% (typical return for corporate finance)
- Loan tenor: 15 years for IPP and EPC commercial financing option and 25 years for EPC with sovereign guarantee and DFI financing.

It should be mentioned that a 3.5% interest rate seems to be somewhat low, and based on K&M's previous experience, the interest rate for this Project could potentially be higher and around 5% (for DFIs) and 8% or more (for commercial banks). K&M analyzed the sensitivity of project profitability and tariff against different variables, including interest rate, and the results of the analysis are presented in Section 14.5.

**Tariff:** The resulting average tariffs over the Project life for different financing approaches and gas availability scenarios are presented in Table 14.3 below. The EPC options consider two debt financing scenarios – commercial bank finance with loan tenor of 15 years and interest rate of 8%

and DFI financing coupled with sovereign guarantee resulting in loan tenor of 25 years and interest rate of 3.5%.

**Table 14.3: Tariff Analysis**

Average Tariff (US cents/kWh) Approach	Wartsila		LM2500 CC	
	30 MMSCFD	50 MMSCFD	30 MMSCFD	50 MMSCFD
IPP	7.1	6.95	7.49	7.35
EPC (commercial loan)	6.64	6.55	6.8	6.7
EPC (DFI loan)	6.17	6.09	6.1	6.0

We can make the following conclusions from the tariff analysis:

- For the scenarios with loan tenor of 15 years for both IPP and EPC structures the Wartsila options result in a slightly lower per unit tariff than LM 2500 CC options. Even though the LM 2500 CC has a better heat rate than Wartsila RICE, the comparatively lower capital costs for the Wartsila option drives down the per unit tariff. The detailed tariff and cost analysis for base case are provided in Section 14.3 and 14.4 respectively.
- For the EPC scenario with 25 year loan tenor based on assumption that the Government of Guyana provides sovereign guarantee and the project debt is financed by DFIs, the average tariff decreases by between approximately 0.5 US cents/kWh for RICE option to 0.7 US cents/kWh for CC options compared to the commercial loan option. Additionally, LM2500 CC option becomes slightly less expensive for DFI option as better heat rate and resulting reduction in fuel cost compensates for higher capital cost when debt repayment is spread over a longer period.
- The tariffs for the EPC financing model are lower than the tariffs for the IPP financed model. This is expected since the corporate finance using EPC has lower development and financing costs and cost of capital. However, as explained in Section 13 corporate finance using EPC is riskier as all the project completion and development, construction, and operation risks will be borne by GPL. Also, it might be difficult for GPL to raise the required capital requirements for the Project using a Corporate Finance approach.

The base case assumptions are summarized in Table 14.4

**Table 14.4: Base Case Assumptions**

Assumptions	Base Case				Units
	Wartsila		LM2500 CC		
	30 MMSCFD	50 MMSCFD	30 MMSCFD	50 MMSCFD	
<b>Technical</b>					
Net Capacity (AC)	153	255	180	304	MW
Year 1 Generation	805,484	701,917	880,088	727,159	MWh
Guaranteed Heat Rate	7,724		6,780		Btu/kWh
Operating Life	25				Years
Natural Gas Cost	4.7 (From Expansion Study)				US\$/MMBTu
Unit Size	17		30		MW
<b>Commercial and Financial</b>					
Inflation (US CPI)	2.82%				%
Required Equity IRR (nominal)	15% (IPP), 8% (EPC)				%/year
Leverage	70%				%
Interest Rate (nominal)	3.5% for IPP and EPC with DFI; 8% for commercial loan				%
Debt Tenor	15 for IPP and EPC with commercial loan, 25 years for DFI				years
Debt Repayment Model	Equal Principal				-
Capital Costs (IPP)	1,071	1,026	1,469	1,410	USD/kW
Capital Costs (EPC)	997	941	1,348	1,293	USD/kW
Fixed O&M	18		27		USD/kW-yr
Variable O&M	6.0		3.0		USD/MWh

Annual generation is estimated using the results of the demand and supply analysis performed as part of Section 4.

Plant heat rates are based on the results of conceptual design presented in Section 11.

Capital cost used for the modeling is based on the capital cost estimate presented in Section 12 of this report.

Fixed and variable O&M costs are based on the estimates performed as part of Section 9.

### 14.3 Tariff Analysis

The financial analysis calculates the tariff required by the Project to achieve an after-tax equity rate of return of 15% for IPP based project and 8% for Corporate Financed EPC based project. In both cases, the tariff is assumed to be paid in (or fully indexed to) U.S. Dollars for a PPA term of 25 years.

The calculated tariff is made up of the following:

- 1 Fixed Capacity Charge (FCC – US\$/kW-yr):** The fixed capacity charge is a payment that is paid per period (annually) for each kilowatt of available (not dispatched) capacity. It includes

costs involved in construction of the power plant including repayment of debt obligations and return on equity invested. The FCC is calculated separately for each phased expansion provided in Table 14.1 in the previous section.

- 2 **Fixed O&M Charge (FOMC – US\$/kW-yr):** The fixed operation and maintenance charge is the payment for O&M costs that are independent of the amount of energy generated like staff, administrative expenses, insurance premiums, etc.
- 3 **Variable O&M Charge (VOMC – US\$/MWh):** The variable operation and maintenance charge is payment for variable O&M costs incurred during the operation of the power plant like spare parts, lubricants, and other consumables.
- 4 **Fuel Charge (FC – US\$/MWh):** Fuel charge is the payment for each MMBTU of natural gas consumed during the operation.

The year 1 tariff is calculated using the excel goal-seek function which uses an iterative method to calculate the required capacity charge (as all other charges are costs that are passed on to the customer without a margin). The goal is to adjust the FCC until an Equity IRR of 15% or 8% is achieved based on the Project's free cash flows to equity. The equity cash flows are calculated from the cash flow statement, and are equal to the operating cash flow, minus principal repayment. The operating cash flow is equal to the net profit calculated from the profit and loss statement, after adjustments based on changes in working capital and adding back depreciation. The net profit in the profit and loss statement is calculated as the revenue from selling electricity under the PPA, minus operating and maintenance costs, fuel costs, depreciation, interest and taxes. The revenue is calculated by multiplying the tariff with the expected generation. The tariff calculation methodology is illustrated in Figure 14.2.

**Figure 14.2: Tariff Calculation**

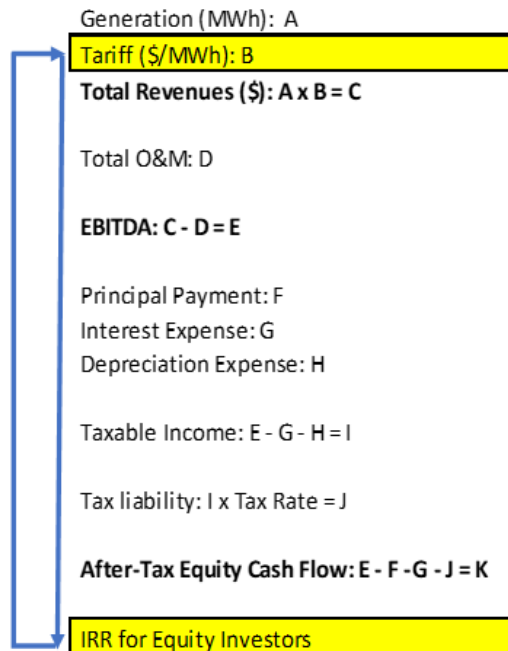

The tariffs for the different options are provided below:

### 14.3.1 Wartsila RICE option, 30 MMSCFD gas supply

The tariff for this option starts at 6.8 (IPP) or 6.0 (EPC) US cents/kWh for year 1 and increases to 7.5 (IPP) or 6.7 (EPC) US cents/kWh by year 25 with an average tariff of 7 (IPP) or 6.3 (EPC) US cents / kWh. The increase in tariff is due to increase in expenses due to inflation. The fixed capacity charge for the two phases and the annual tariff breakdown for IPP and EPC based approaches are provided below:

**Figure 14.3: Tariff Breakdown for Wartsila 30 MMSCFD Gas Supply Scenario – IPP based**

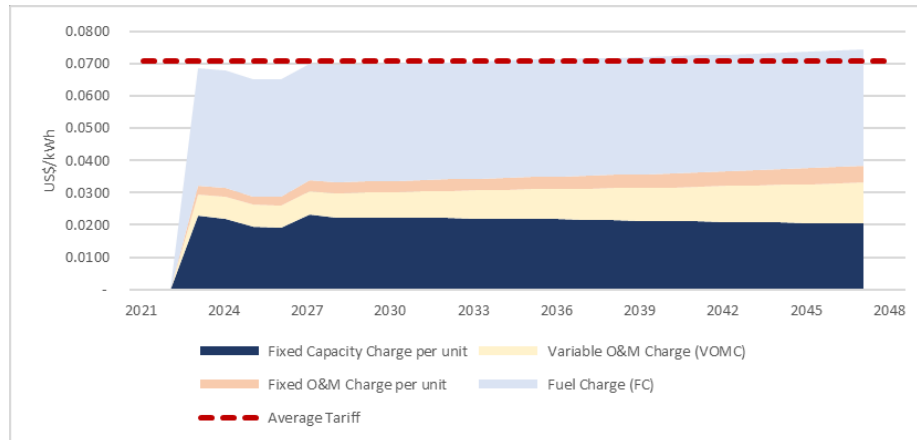

Description	Value	Unit
<b>Average Tariff</b>	<b>0.0709</b>	<b>US\$/kWh</b>
Phase 1 Fixed Capacity Charge (FCC1)	154.07	US\$/kW-yr
Phase 2 Fixed Capacity Charge (FCC2)	149.17	US\$/kW-yr

**Figure 14.4: Tariff Breakdown Wartsila RICE, 30 MMSCFD - EPC based (Commercial Loan)**

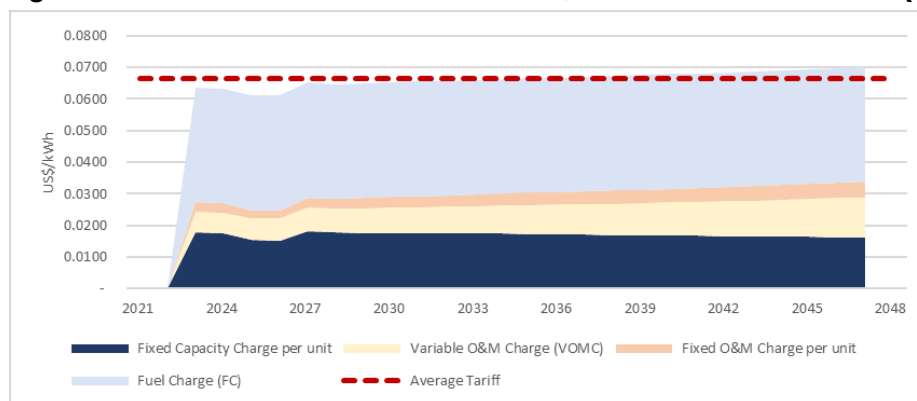

Description	Value	Unit
<b>Average Tariff</b>	<b>0.06639</b>	<b>US\$/kWh</b>
Phase 1 Fixed Capacity Charge (FCC1)	120.35	US\$/kW-yr
Phase 2 Fixed Capacity Charge (FCC2)	122.19	US\$/kW-yr



**Figure 14.5: Tariff Breakdown Wartsila RICE, 30 MMSCFD - EPC based (DFI Loan)**

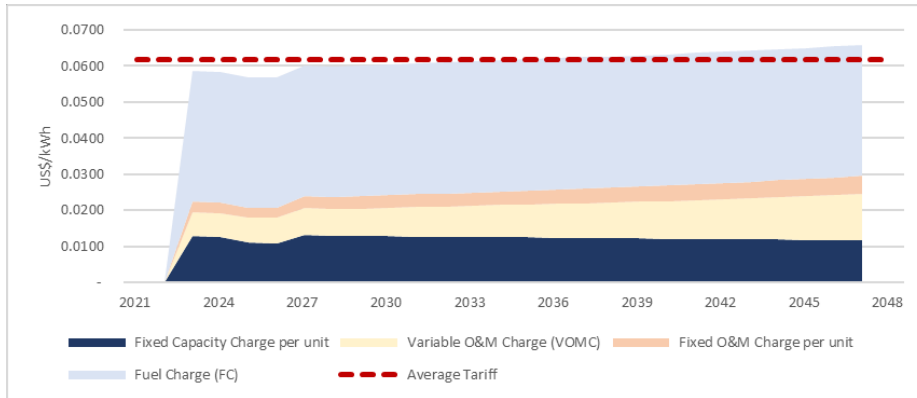

Description	Value	Unit
<b>Average Tariff</b>	<b>0.06174</b>	<b>US\$/kWh</b>
Phase 1 Fixed Capacity Charge (FCC1)	87.76	US\$/kW-yr
Phase 2 Fixed Capacity Charge (FCC2)	86.49	US\$/kW-yr

### 14.3.2 Wartsila RICE option, 50 MMSCFD gas supply

The tariff for this option starts at 6.7 (IPP) or 5.9 (EPC) US cents/kWh for year 1 and increases to 7.3 (IPP) or (6.6) US cents/kWh by year 25 with an average tariff of 6.9 (IPP) or 6.2 (EPC) US cents / kWh. The fixed capacity charge for the each of the six phases in the expansion and the annual tariff breakdown is provided below:

**Figure 14.6: Tariff Breakdown Wartsila RICE, 50 MMSCFD - IPP**

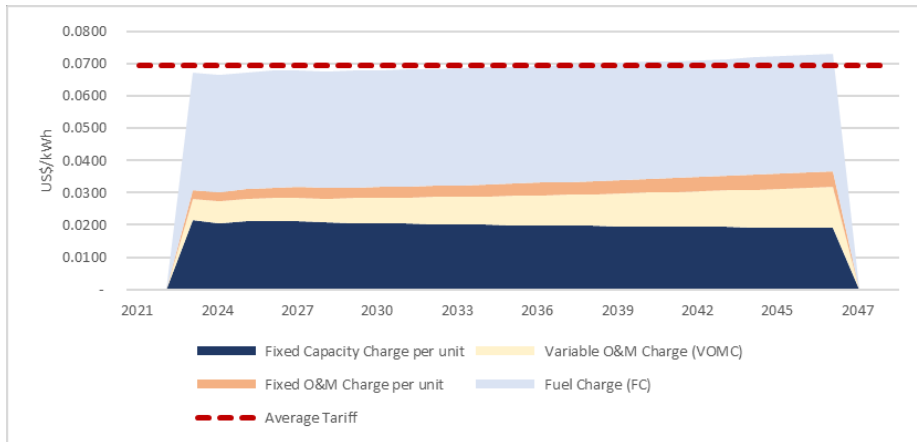

Description	Value	Unit
<b>Average Tariff</b>	<b>0.0695</b>	<b>US\$/kWh</b>
Phase 1 Fixed Capacity Charge (FCC1)	147.92	US\$/kW-yr
Phase 2 Fixed Capacity Charge (FCC2)	141.68	US\$/kW-yr
Phase 3 Fixed Capacity Charge (FCC3)	142.66	US\$/kW-yr
Phase 4 Fixed Capacity Charge (FCC4)	144.12	US\$/kW-yr
Phase 5 Fixed Capacity Charge (FCC5)	145.23	US\$/kW-yr
Phase 6 Fixed Capacity Charge (FCC6)	146.59	US\$/kW-yr

**Figure 14.7: Tariff Breakdown Wartsila RICE, 50 MMSCFD – EPC (Commercial Loan)**

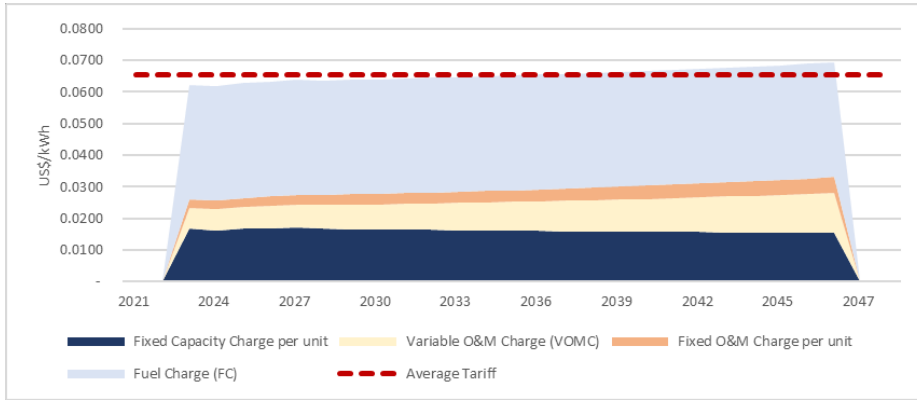

Description	Value	Unit
<b>Average Tariff</b>	<b>0.0655</b>	<b>US\$/kWh</b>
Phase 1 Fixed Capacity Charge (FCC1)	114.24	US\$/kW-yr
Phase 2 Fixed Capacity Charge (FCC2)	114.14	US\$/kW-yr
Phase 3 Fixed Capacity Charge (FCC3)	116.59	US\$/kW-yr
Phase 4 Fixed Capacity Charge (FCC4)	119.18	US\$/kW-yr
Phase 5 Fixed Capacity Charge (FCC5)	121.96	US\$/kW-yr
Phase 6 Fixed Capacity Charge (FCC6)	125.20	US\$/kW-yr

**Figure 14.8: Tariff Breakdown Wartsila RICE, 50 MMSCFD – EPC (DFI Loan)**

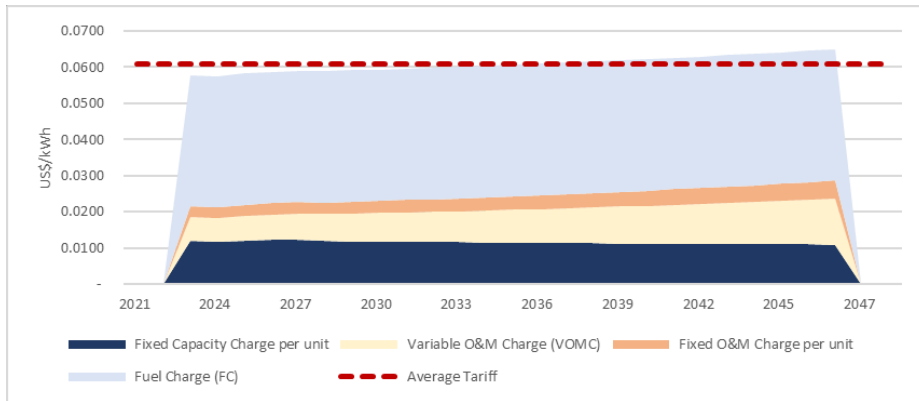

Description	Value	Unit
<b>Average Tariff</b>	<b>0.0609</b>	<b>US\$/kWh</b>
Phase 1 Fixed Capacity Charge (FCC1)	83.48	US\$/kW-yr
Phase 2 Fixed Capacity Charge (FCC2)	81.36	US\$/kW-yr
Phase 3 Fixed Capacity Charge (FCC3)	82.53	US\$/kW-yr
Phase 4 Fixed Capacity Charge (FCC4)	83.38	US\$/kW-yr
Phase 5 Fixed Capacity Charge (FCC5)	84.33	US\$/kW-yr
Phase 6 Fixed Capacity Charge (FCC6)	85.41	US\$/kW-yr

### 14.3.3 LM 2500 CC, 30 MMSCFD gas supply

The tariff for this option starts at 6.8 (IPP) or 5.7 (EPC) US cents/kWh for year 1 and increases to 7.7 (IPP) or 6.6 (EPC) US cents/kWh by year 25 with an average tariff of 7.5 (IPP) or 6.3 (EPC) US cents / kWh. The fixed capacity charge for the three phases and the annual tariff breakdown is provided below:

**Figure 14.9: Tariff breakdown for LM 2500 CC, 30 MMSCFD gas supply - IPP**

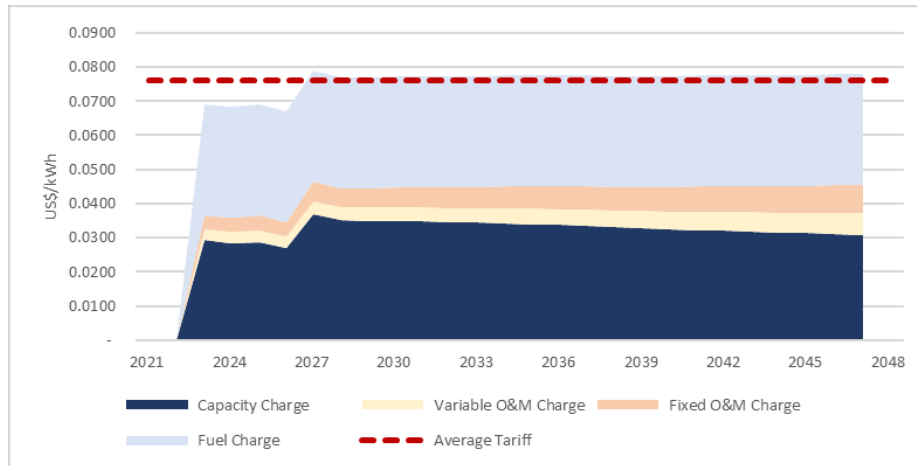

Description	Value	Unit
<b>Average Tariff</b>	<b>0.0750</b>	<b>US\$/kWh</b>
Phase 1 Fixed Capacity Charge (FCC1)	212.09	US\$/kW-yr
Phase 2 Fixed Capacity Charge (FCC2)	204.74	US\$/kW-yr
Phase 3 Fixed Capacity Charge (FCC3)	205.87	US\$/kW-yr

**Figure 14.10: Tariff Breakdown LM2500 CC, 30 MMSCFD – EPC (Commercial Loan)**

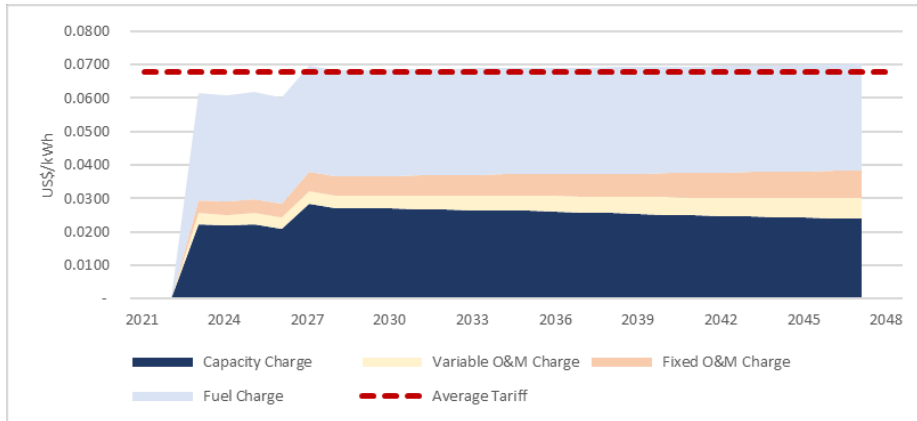

Description	Value	Unit
<b>Average Tariff</b>	<b>0.06796</b>	<b>US\$/kWh</b>
Phase 1 Fixed Capacity Charge (FCC1)	163.09	US\$/kW-yr
Phase 2 Fixed Capacity Charge (FCC2)	164.40	US\$/kW-yr
Phase 3 Fixed Capacity Charge (FCC3)	168.09	US\$/kW-yr

**Figure 14.11: Tariff Breakdown LM2500 CC, 30 MMSCFD – EPC (DFI Loan)**

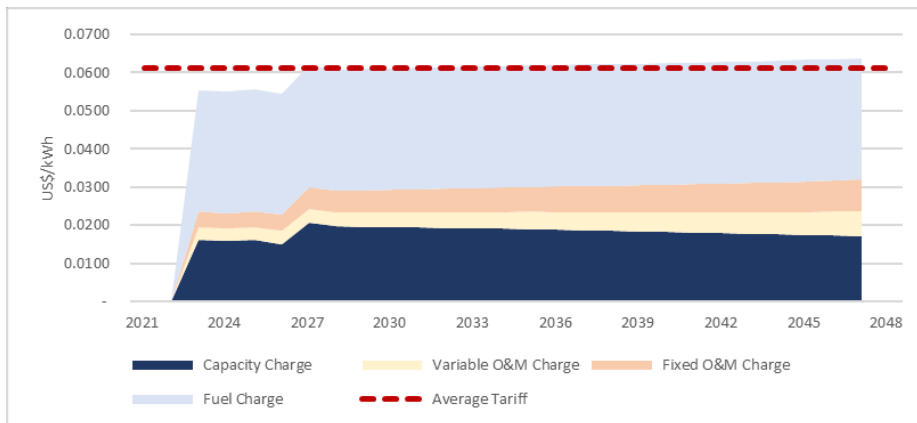

Description	Value	Unit
<b>Average Tariff</b>	<b>0.06104</b>	<b>US\$/kWh</b>
Phase 1 Fixed Capacity Charge (FCC1)	119.27	US\$/kW-yr
Phase 2 Fixed Capacity Charge (FCC2)	116.83	US\$/kW-yr
Phase 3 Fixed Capacity Charge (FCC3)	118.48	US\$/kW-yr

#### 14.3.4 LM 2500 CC, 50 MMSCFD gas supply

The tariff for this option starts at 7.4 (IPP) or 6.1 (EPC) US cents/kWh for year 1 and increases to 7.6 (IPP) or 6.6 (EPC) US cents/kWh by year 25 with an average tariff of 7.35 (IPP) or 6.3 (EPC) US cents / kWh. The fixed capacity charge for the two phases and the annual tariff breakdown is provided below:

**Figure 14.12: Tariff breakdown LM 2500 CC, 50 MMSCFD gas supply - IPP**

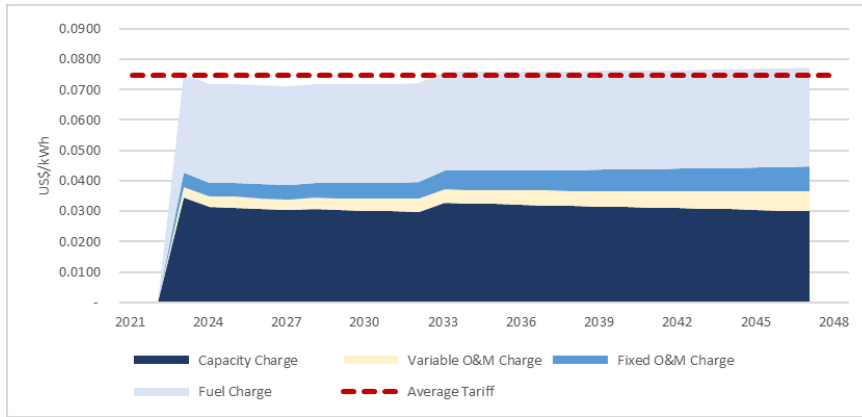

Description	Value	Unit
<b>Average Tariff</b>	<b>0.0735</b>	<b>US\$/kWh</b>
Phase 1 Fixed Capacity Charge (FCC1)	205.75	US\$/kW-yr
Phase 2 Fixed Capacity Charge (FCC2)	196.02	US\$/kW-yr
Phase 3 Fixed Capacity Charge (FCC3)	197.32	US\$/kW-yr
Phase 4 Fixed Capacity Charge (FCC4)	198.78	US\$/kW-yr
Phase 5 Fixed Capacity Charge (FCC5)	200.43	US\$/kW-yr
Phase 6 Fixed Capacity Charge (FCC6)	202.30	US\$/kW-yr
Phase 7 Fixed Capacity Charge (FCC7)	216.52	US\$/kW-yr

**Figure 14.13: Tariff breakdown LM 2500 CC, 50 MMSCFD gas supply- EPC (Commercial Loan)**

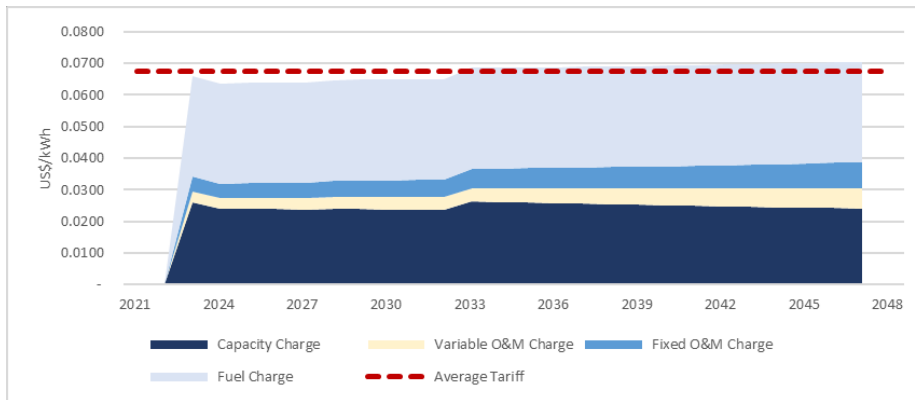

Description	Value	Unit
<b>Average Tariff</b>	<b>0.067</b>	<b>US\$/kWh</b>
Phase 1 Fixed Capacity Charge (FCC1)	158.15	US\$/kW-yr
Phase 2 Fixed Capacity Charge (FCC2)	156.97	US\$/kW-yr
Phase 3 Fixed Capacity Charge (FCC3)	160.31	US\$/kW-yr
Phase 4 Fixed Capacity Charge (FCC4)	163.86	US\$/kW-yr
Phase 5 Fixed Capacity Charge (FCC5)	167.67	US\$/kW-yr
Phase 6 Fixed Capacity Charge (FCC6)	171.42	US\$/kW-yr
Phase 7 Fixed Capacity Charge (FCC7)	199.09	US\$/kW-yr

**Figure 14.14: Tariff breakdown LM 2500 CC, 50 MMSCFD gas supply- EPC (DFI Loan)**

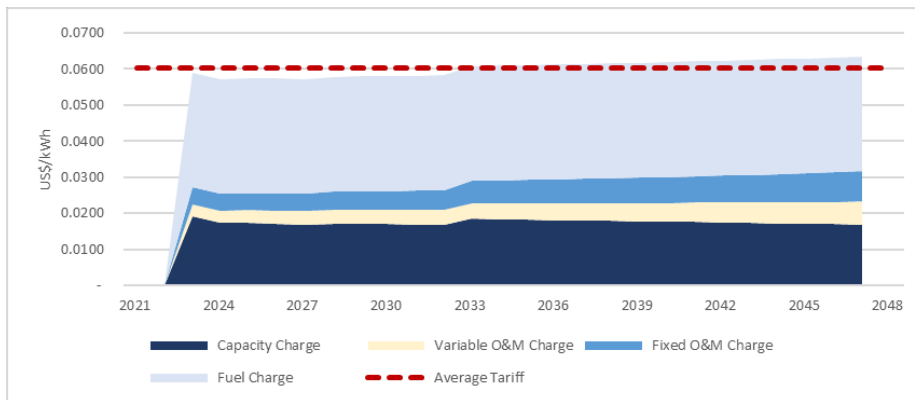

Description	Value	Unit
<b>Average Tariff</b>	<b>0.060</b>	<b>US\$/kWh</b>
Phase 1 Fixed Capacity Charge (FCC1)	115.60	US\$/kW-yr
Phase 2 Fixed Capacity Charge (FCC2)	111.94	US\$/kW-yr
Phase 3 Fixed Capacity Charge (FCC3)	113.15	US\$/kW-yr
Phase 4 Fixed Capacity Charge (FCC4)	114.80	US\$/kW-yr
Phase 5 Fixed Capacity Charge (FCC5)	116.09	US\$/kW-yr
Phase 6 Fixed Capacity Charge (FCC6)	117.53	US\$/kW-yr
Phase 7 Fixed Capacity Charge (FCC7)	127.26	US\$/kW-yr

## 14.4 Life Cycle Cost and Levelized Cost of Electricity

### 14.4.1 Life Cycle Cost Analysis

Life cycle cost analysis is a method for expressing the entire cost of the Project over its expected useful life in a single cost in today's dollars. It is calculated by taking the present value of all costs (including Capital Costs, O&M Costs, Fuel Costs, etc.) incurred over the life of a project at the discount rate of 8% that is a typical cost of capital for regulated power utilities. The results of the Life Cycle Cost Analysis are provided in Table 14.5.

**Table 14.5: Life Cycle Cost Analysis Results**

Description	Wartsila RICE		LM 2500 CC	
	30 MMSCFD	50 MMSCFD	30 MMSCFD	50 MMSCFD
<b>IPP</b>				
<b>Life Cycle Costs</b>	669 Million USD	983 Million USD	745 Million USD	1,056 Million USD
<b>Upfront Capital Costs including interest during construction</b>	174 Million USD	277 Million USD	284 Million USD	456 Million USD
<b>EPC (Commercial Loan)</b>				
<b>Life Cycle Costs</b>	645 Million USD	950 Million USD	706 Million USD	1,006 Million USD
<b>Upfront Capital Costs including interest during construction</b>	171 Million USD	271 Million USD	273 Million USD	440 Million USD
<b>EPC (DFI Loan)</b>				
<b>Life Cycle Costs</b>	630 Million USD	927 Million USD	683 Million USD	970 Million USD
<b>Upfront Capital Costs including interest during construction</b>	162 Million USD	255 Million USD	258 Million USD	413.7 Million USD

#### 14.4.2 Levelized Cost of Electricity

The Levelized Cost of Electricity is defined as the flat cost of electricity per kilowatt hour generated by the project or a system over a given timeframe (usually life of the project) that results in the same present value as the present value of the actual cost of electricity per kWh (or tariff) that varies from year to year depending on annual electricity generation and tariff escalation. LCOE is an important metric when comparing the cost per unit generation of a project with competing alternatives, including current generation sources. The standard methodology for calculating the LCOE is described below.

$$LCOE \left( \frac{USD}{MWh} \right) = \sum \frac{PV(Costs (USD \text{ per year}))}{PV(Generation (MWh \text{ per year}))}$$

LCOE can be expressed in two ways: “real” LCOE and “nominal” LCOE.

The nominal LCOE is the average cost per unit of electricity which includes expected inflation over the entire project life. The real LCOE is the average unit cost expressed in today’s terms, excluding forecasted inflation. The real and nominal LCOE for the options and the expected lifetime generation for each is presented in the table below.

**Table 14.6: Levelized Cost of Energy**

Description	Wartsila RICE		LM 2500 CC	
	30 MMSCFD	50 MMSCFD	30 MMSCFD	50 MMSCFD
<b>IPP</b>				
<b>Nominal LCOE (US\$/MWh)</b>	68.01	65.41	71.33	70.99
<b>Real LCOE (US\$/MWh)</b>	48.87	45.43	51.06	49.18
<b>Lifetime Generation (GWh)</b>	27,140	43,391	28,953	44,784
<b>EPC (Commercial Loan)</b>				
<b>Nominal LCOE (US\$/MWh)</b>	65.92	65.41	67.61	67.59
<b>Real LCOE (US\$/MWh)</b>	47.15	45.43	48.4	46.83
<b>Lifetime Generation (GWh)</b>	27,140	43,391	28,953	44,784
<b>EPC (DFI Loan)</b>				
<b>Nominal LCOE (US\$/MWh)</b>	64.37	63.82	65.32	65.19
<b>Real LCOE (US\$/MWh)</b>	46.05	44.32	46.76	45.16
<b>Lifetime Generation (GWh)</b>	27,140	43,391	28,953	44,784

As we can see from Table 14.6, the LCOE for the Wartsila RICE options is slightly lower than the LM 2500CC options for both IPP and EPC options.

## 14.5 Sensitivity Analysis

There are a number of factors that impact Project profitability and tariff but not all of these factors are equally likely or equally impactful. K&M performed sensitivity analysis on the following factors which would have the most significant impacts on the Project:

- CAPEX
- Leverage
- Interest Rate
- Natural Gas Price

K&M analyzed Project's profitability (Equity IRR) against changes in CAPEX, leverage, and interest rate for the IPP option. Response to changes to these parameters for the EPC options is similar. We did not include the price of natural gas in our analysis of profitability as fuel costs are passed on in the tariff as a separate fuel charge.

The Project's profitability and the resulting tariff is most sensitive to changes in CAPEX and natural gas price, and moderately sensitive to changes in interest rates and leverage. K&M therefore recommends that GPL or GoG uses an LCOE-based approach to evaluate different bids in order to obtain the best expected value) with a firm heat rate commitment from the EPC contractor during the EPC contract procurement process.



### 14.5.1 CAPEX

As shown in the figure below, the 15% Equity IRR increases to 16% when CAPEX decreases by 5% and decreases to 14% when CAPEX increases by 5%. Similarly, for a +/-5% change in CAPEX, tariff changes by +/- 1 US cents/kWh for Wartsila options and +/- 1.5 US cents/kWh for LM 2500 CC options.

**Figure 14.15: Tariff/IRR sensitivity to CAPEX**

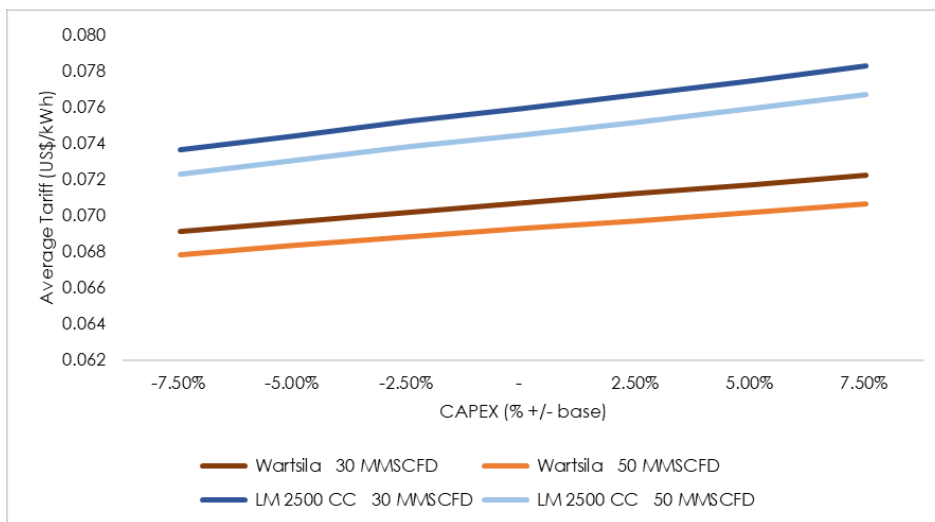
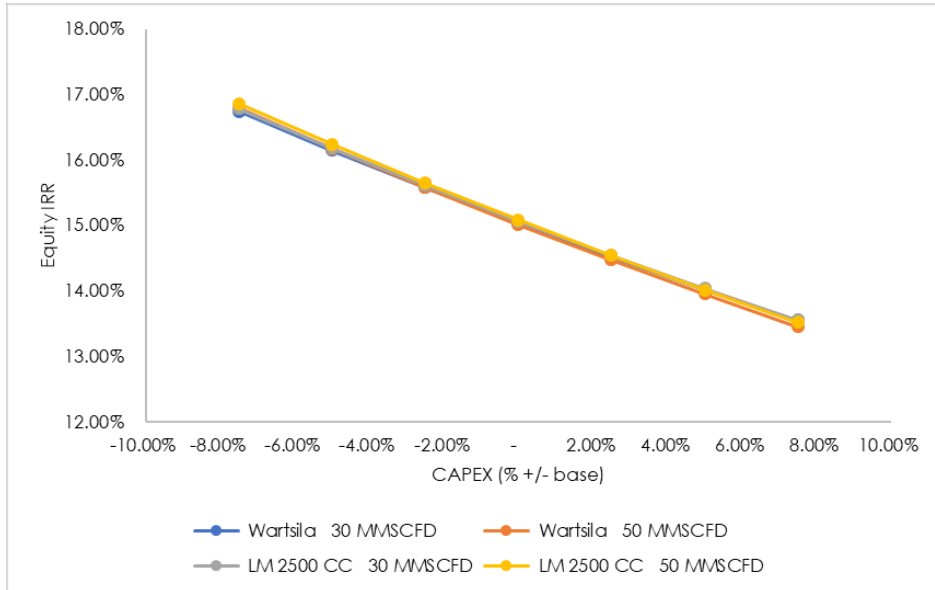

### 14.5.2 Leverage

The Equity IRR is moderately sensitive to changes in leverage. For every 5% increase/decrease in leverage, the IRR changes by approximately 1%. The PPA tariff has an inverse relationship with

leverage; for every 5% increase/decrease, the PPA tariff changes by approximately 1 US cent/kWh.

**Figure 14.16: Tariff/IRR sensitivity to Leverage**

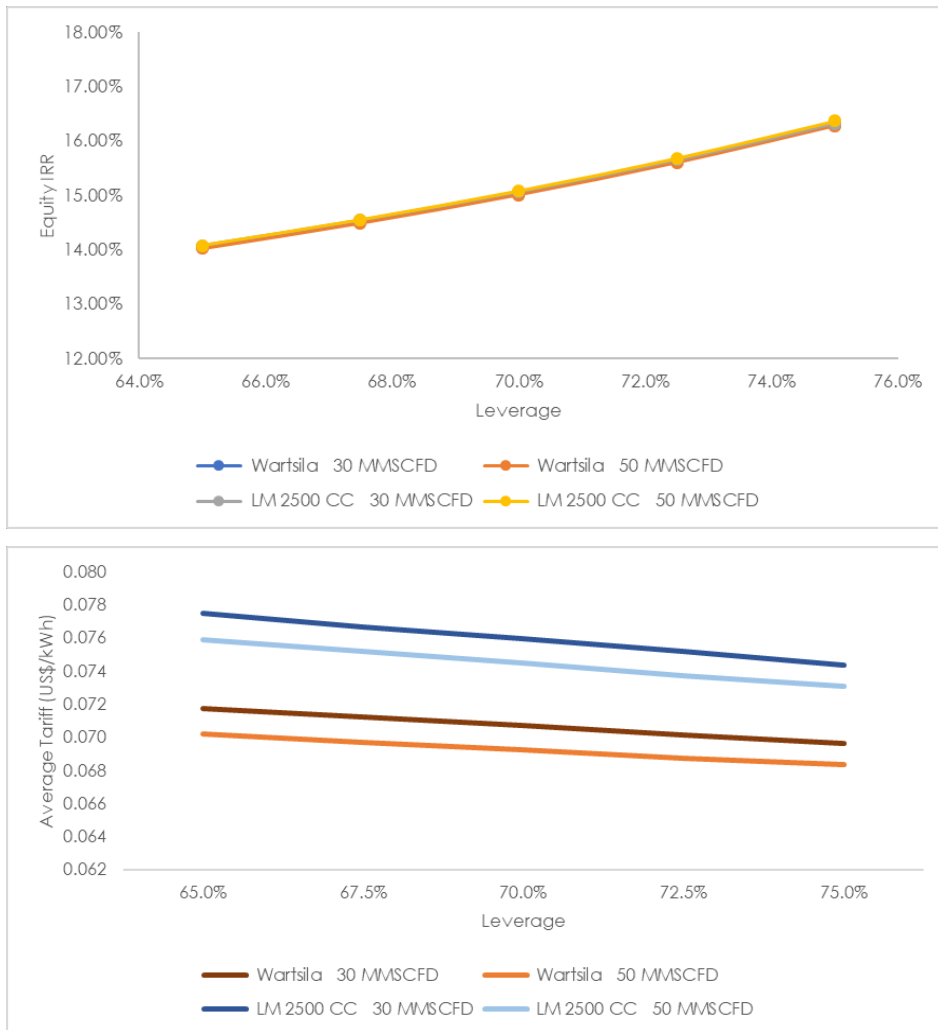

### 14.5.3 Interest Rate

The equity IRR is moderately sensitive to interest rates (with an inverse relationship). For every 50 basis points increase, the equity IRR decreases by 0.5%. Interest rates also moderately effects the tariff as well. For every 50 basis point increase, the tariff increases by 0.5 US cents/kWh.

**Figure 14.17: Tariff/IRR sensitivity to interest rates**

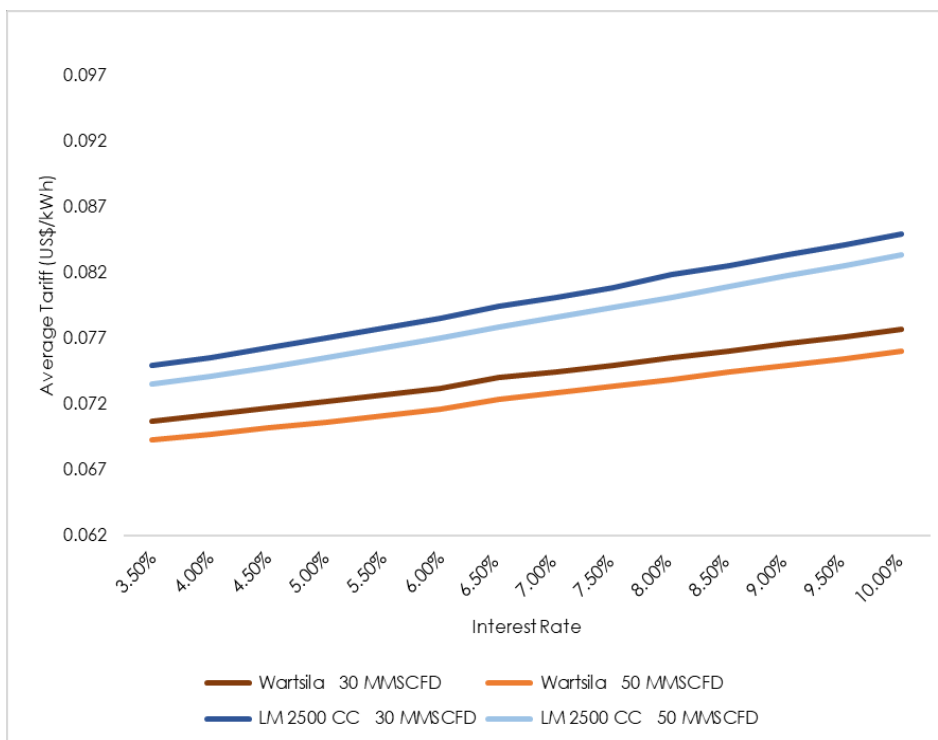
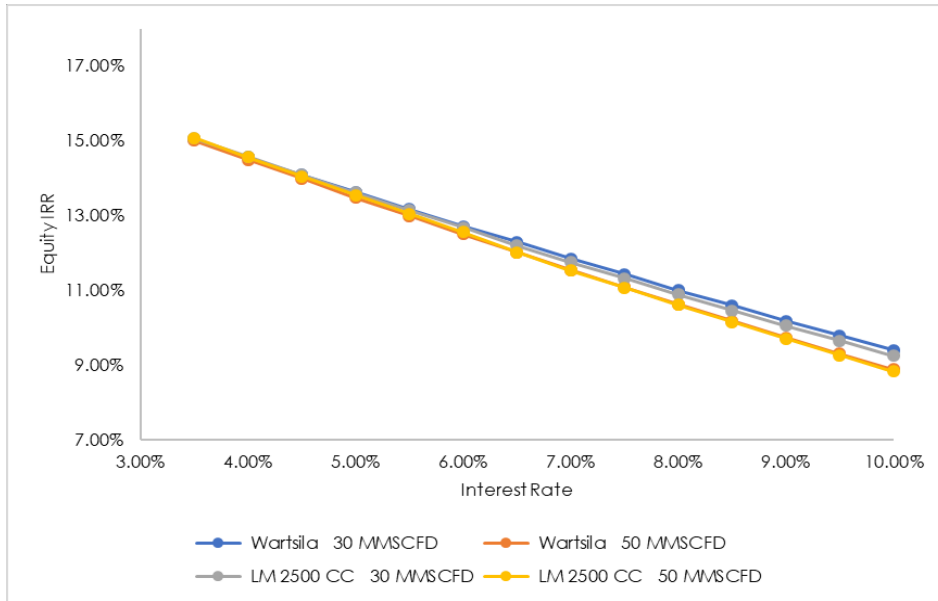

### 14.5.4 Natural Gas Price

The tariff is highly sensitive to changes in price of natural gas. A +/- 10% change in price of natural gas, the tariff changes by +/- 3.6 US cents/kWh for Wartsila options and +/-3.3 US cents/kWh for LM 2500 CC options.

**Figure 14.18: Tariff Sensitivity to Natural Gas Prices**

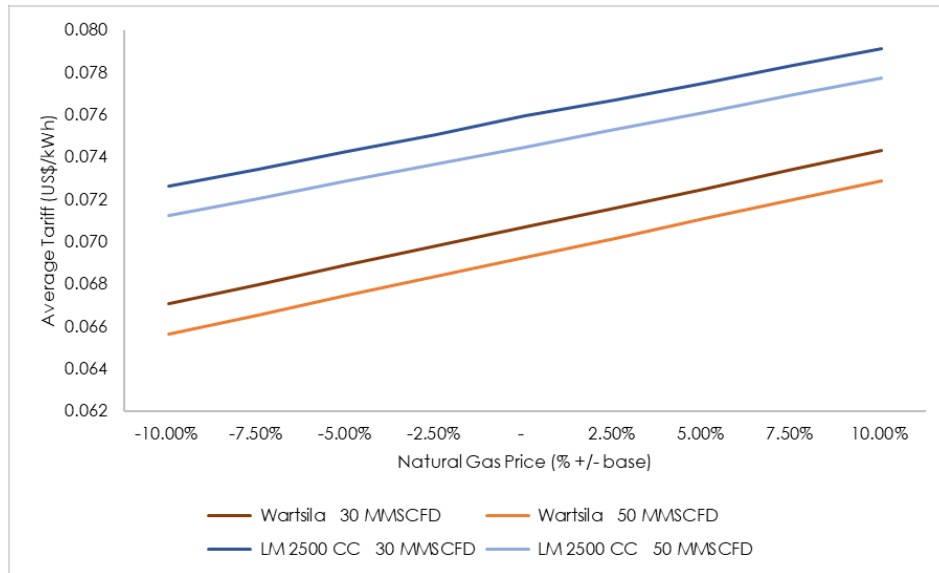

## 14.6 Conclusion

Based on the detailed financial and economic analysis, we can conclude the following

- The Wartsila Options result in a slightly lower tariff and LCOE for both the 30 MMSCFD and 50 MMSCFD gas supply options for IPP and EPC with commercial loan. This is because the Wartsila options have a much lower CAPEX than LM 2500 CC options and compensates for its higher heat rate. Also, the comparatively larger plant size of LM 2500 CC options results in sparer (idle) capacity and contributes to its higher tariff. The tariffs are nearly equal between the Wartsila and LM2500 CC options for EPC with the DFI loan scenario.
- The tariffs for the EPC financing model are lower than the tariffs for the IPP financed model due to the lower cost of capital and reduced soft costs and resulting lower overall project cost for the corporate financed EPC model. However, all risks related to Project development, construction, finance, and operation will be borne by GPL in addition to raising all the required capital for the project on their balance sheet.
- The project profitability and tariff are very sensitive to natural gas price and CAPEX. GoG should employ an LCOE-based approach to evaluate different EPC bids in order to obtain the best expected value with heat rate commitment from the EPC contractor during the EPC contract procurement process. For the IPP approach the GoG is expected to select the preferred IPP developer based on the lowest proposed levelized tariff.

## 15 Dispatch Model

K&M developed an Excel-based 24-hour generation dispatch model as part of this assignment. The dispatch model calculates the generation merit order based on the marginal cost of electricity of each individual generating units for every hour in a 24-hour load forecast. The dispatch model only considers thermal generation. The thermal load for every hour of the day will have to be determined as a total system load minus PV solar generation. The dispatch model uses Solver functions of Excel, which solves for the optimum solution that results in the minimum marginal cost for that load. A copy of the dispatch model in Excel format is submitted as a separate file.

The marginal cost is calculated using the following formula:

$$\text{Marginal Cost of Electricity} \left( \frac{\text{US\$}}{\text{MWh}} \right) = (\text{Fuel Cost} * \text{Heat Rate}) + \text{Variable O\&M}$$

The dispatch model is subject to the following constraints and inputs (some inputs are assumed for illustrative purposes)

### Inputs

- 1 Nominal maximum and minimum unit commitment for each generating unit.
- 2 Minimum spinning reserve allocation and percent spinning reserve allocation for each unit.

Generation Unit	Maximum Unit Commitment - Minimum Spinning Reserve (MW)	Nominal Maximum Unit Commitment (MW)	Nominal Minimum Unit Commitment (MW)	Minimum Spinning Reserve Contribution (MW)
GOE - 1	5.50	5.50	-	0
GOE - 2	5.50	5.50	-	0
GOE - 3	5.50	5.50	-	0
GOE - 4	5.50	5.50	-	0
Kingston 1 - 1	5.50	5.50	-	0
Kingston 1 - 2	5.50	5.50	-	0
Kingston 1 - 3	5.50	5.50	-	0
Kingston 1 - 4	5.50	5.50	-	0
Kingston 2 - 1	6.90	6.90	-	0
Kingston 2 - 2	6.90	6.90	-	0
Kingston 2 - 3	6.90	6.90	-	0
Kingston 2 - 4	7.80	7.80	-	0
Kingston 2 - 5	7.80	7.80	-	0
Vreed-en-Hoop 1	8.70	8.70	-	0
Vreed-en-Hoop 2	8.70	8.70	-	0
Vreed-en-Hoop 3	8.70	8.70	-	0
	-	-	-	0
	-	-	-	0
New 1	17.00	17.00	2.00	0
New 2	17.00	17.00	2.00	0
New 3	17.00	17.00	2.00	0
New 4	17.00	17.00	2.00	0

- 3 System Spinning Reserve Targets.

Spinning Reserve Target (MW)

34.00

- 4 System load targets for 24 hours

<b>Hour</b>	0:00	1:00	2:00	3:00	4:00														22:00	23:00
<b>Load Values</b>	90	85	80	65	60														155	112

- 5 Primary and Secondary Fuel percentage for each unit
- 6 Heat input curves defined by a quadratic polynomial equation with the following coefficients for new and existing generators.

**Existing Units Heat Input Curve Coefficients**

<b>Unit</b>	<b>A</b>	<b>B</b>	<b>C</b>
Kingston 1	0.54	(92.53)	12,069.00
Kingston 2	0.42	(78.26)	11,673.00
GOE	0.49	(87.58)	11,749.00
Vreed-en-Hoop	0.48	(84.56)	11,491.00

**New Plant Heat Input Coefficients**

<b>a</b>	<b>b</b>	<b>c</b>
(0.0951)	8.9589	6.1359

- 7 Variable O&M costs for new and existing generators.

<b>Generation Unit</b>	<b>VOM (\$/MWH)</b>
Kingston 1	8.9
Kingston 2	9.8
GOE	9.8
Vreed-en-Hoop	9.8
New Power Plant	6.7

- 8 Applicable fuel prices for new and existing generators. Note that HFO is the primary fuel used for the existing plants and Natural Gas is the primary fuel used or the new power plant in the model.

HFO (\$/MMBTU)	\$ 8.73
Natural Gas (\$/MMBTU)	\$ 4.70

**Constraints**

- 1 Unit dispatch is more than minimum unit commitment and less than the maximum unit commitment. Maximum unit commitment is calculated as the difference of nominal maximum unit commitment and system reserve allocation.
- 2 Spinning reserve is more than spinning reserve target,
- 3 Committed dispatch is equal to the system load target.



## 16 Grid Impact Analysis

---

A power flow study was used to analyze the ability to evacuate power from the new gas fired power plant to serve grid load while displacing the present conventional generation in Guyana. Two future-year load scenarios were studied: year 2023 projected loads (the expected year of plant commissioning) and year 2035 projected loads as a study horizon-year. For each of those study years two gas supply levels were analyzed: 30 MMscfd and 50 MMscfd supply scenarios. Additionally, each year and gas supply level was analyzed under three separate injection scenarios:

- 1 Inject the new plant power output on a new 69 kV line constructed between the Good Hope and Columbia substations and a new 69 kV line constructed between the new gas fired power plant and the New Sophia substation;
- 2 Inject the new plant power output on a new 230 kV bus proposed to be constructed at the New Sophia substation; and
- 3 Inject the new plant power output simultaneously to the Good Hope – Columbia 69 kV line and the 230 kV bus at the New Sophia substation.

For all of the above injection scenarios it was assumed that the distance between a generic site of the new gas fired power plant and New Sophia Substation will be approximately 15 km so that the plant will be relatively close to Georgetown, the major load center.

In 2023 the 30 MMscfd gas supply scenario is expected to produce a peak plant power output of 170 MW while the 50 MMscfd gas supply scenario is expected to produce a 200 MW peak power output. The 2035 study year analyzed a 170 MW peak plant power output for the 30 MMscfd gas supply scenario and a 272 MW peak plant power output for the 50 MMscfd gas supply scenario.

GPL supplied a 2018 PSS/E power flow model and projected coincidental aggregated system peak load forecast values used for the plant power evacuation analyses. The GPL-supplied 2018 model coincidental peak load is 151 MW. The GPL-supplied aggregate load forecast suggests a grid coincidental peak load of 227 MW in 2023, and 331 MW in 2035. Using those values, 2023 PSS/E base cases were developed by growing the 2018 model individual bus loads uniformly to a system peak of 227 MW. The resulting 2023 model bus loads were, in turn, grown uniformly, using the supplied aggregate demand forecast, to a 331-MW system peak to create the 2035 power flow base cases.

Prior to analyzing the grid power flow with the new plant output, the PSS/E model was updated with the following input from GPL regarding additional generation expected to be connected to the grid in the future. The 2023 model included these generation updates prior to the new gas plant energization (The battery, wind and PV facilities are not expected to be in service by 2023, according to GPL input):

- 1 35 MW conventional power plant at the Garden of Eden substation
- 2 17 MW conventional power plant at the Onverwagt substation

Both new generators are modeled as being fully dispatchable to meet the expected 2023 peak load of 227 MW and the expected 2035 peak load of 331 MW.

Additional generation (other than the new gas plant) totaling 98 MW is expected to be connected to the grid by 2035, in the form of renewable generation:



- 1 10 MW PV at a new Kuru substation
- 2 10 MW PV at a new Wales substation
- 3 10 MW PV at Canefield substation
- 4 10 MW PV at Golden Grove substation
- 5 10 MW PV at Edinburgh substation
- 6 68 MWh battery at New Sophia substation. Assume 2-hr discharge rate, so model a 34 MW peak-output battery.
- 7 10 MW wind plant called Hope Beach Wind, near the existing Good Hope substation
- 8 4 MW PV on distribution system at Onverwagt substation

These proposed renewable generators are included in the 2035 model and are modeled at an expected output coincidental with the typical evening peak load demand occurring between 5 PM and 6 PM. At that time of day it is expected all PV plant output is near zero MW. The Hope Beach wind plant output was modeled at 3.3 MW (the average 33% capacity factor for typical wind plants). The battery was modeled as fully dispatchable at any time of day. As modeled PV plant output decreases in the afternoon, modeled conventional generation at the Kingston and Vreed-en-Hoop plants increases to provide generation-load-loss balance.

For both model years conventional generation is displaced by the new gas plant power output, while renewable generation is not displaced by the new gas plant output.

These model years, injection locations and gas supply scenarios resulted in the development of 12 separate PSS/E power flow models for grid impact analysis, as shown in the table below. In the 2035 model, for 50 MMscfd scenarios the renewables were scaled back in order to analyze the maximum gas plant injection amount (272 MW), thereby determining the maximum grid impact due to the gas plant addition. The actual generation dispatch would utilize the maximum available renewable energy (RE) and make up the shortfall with the next-lowest-cost resource. Additional generation to supply system losses is also considered.

**Figure 16.1: Internet PV Solar Irradiation Data**

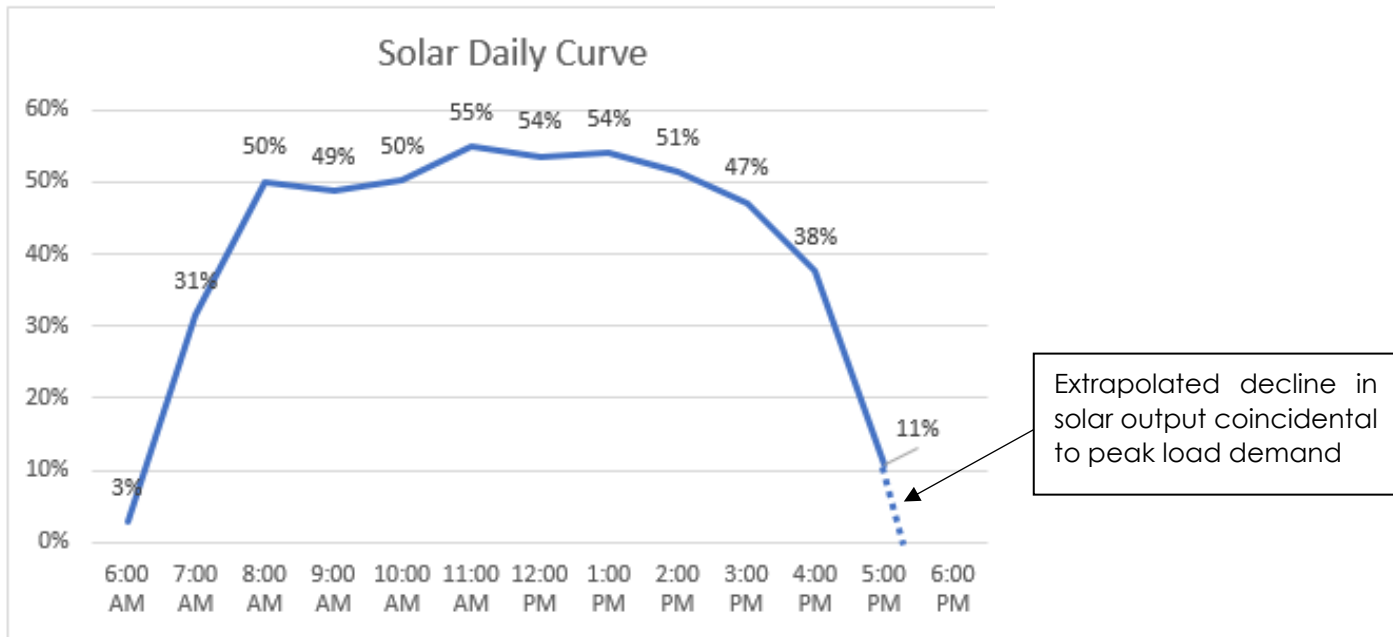

**Table 16.1: Power Flow Models Developed**

Model Year (Grid Coincidental Peak Load)	Gas Supply Scenario (Generation Amount Supplying Load and Type)	Injection Location
2023 (227 MW)	30 MMscfd (170 MW gas; 57 MW oil)	69 kV
		230 kV
		69 kV and 230 kV
	50 MMscfd (200 MW gas; 27 MW oil)	69 kV
		230 kV
		69 kV and 230 kV
2035 (331 MW)	30 MMscfd (37 MW RE; 170 MW gas; 124 MW oil)	69 kV
		230 kV
		69 kV and 230 kV
	50 MMscfd (37 MW RE; 272 MW gas; 22 MW oil)	69 kV
		230 kV
		69 kV and 230 kV

Source: K&M

The GPL system topology is depicted in the model one-line diagram in Figure 16.2 below, with the new gas plant equivalent model designated by the label 'NG' near the center of the diagram. The plant was modeled as a single unit plus a single equivalent generator comprising the balance

of the gas plant, instead of modeling the entire facility as a single equivalent generator. Modeling a single unit plus a balance-of-plant equivalent unit expedites contingency analyses to evaluate the effect of a single plant unit dropping off-line. Modeling the entire plant as a single equivalent generator fails to evaluate the loss of a single unit, while modeling all units separately adds unnecessary complexity while offering no added value in contingency analyses.

The contingency analysis incorporated taking every single branch out-of-service, one at a time (N-1 contingencies), then specific double-element outages were modeled (N-2 contingencies), then specific contingencies comprised of maintenance outages with single outages (N-1-1 contingencies), followed by extreme events comprised of an entire substation taken out-of-service (EE). After each contingency occurs, the model is solved for power flow and violations caused by the contingency are recorded. Violations recorded could be low bus voltages, high bus voltages or overloaded lines or transformers.

Violation criteria used in this study were:

- Bus voltages lower than 0.95 per-unit (p.u.)
- Bus voltages higher than 1.05 p.u.
- Line or transformer loading greater than 100% of Rate A (typically the normal thermal limit)

The contingencies analyzed included:

- 1 N-1 (single) contingencies: use the automated PSS/E ACCC analyses. This includes individual failure of the new lines leaving the proposed new power station – each new 69 kV or 230 kV line is taken out of service, one at a time.
- 2 N-2 (Double contingencies) of parallel lines (two lines on the same towers or two lines in the same right-of-way) going out of service at the same time (the line identification numbers used in description below are the identification numbers currently used by GPL). Model these double contingencies as:
  - a) LS6 – L5 (Kingston – Vreed-en-Hoop submarine cable and Sophia – Kingston)
  - b) L16 – L5 (New Sophia – Good Hope and Sophia – Kingston)
  - c) L1 – L3 (Golden Grove – Garden of Eden and Golden Grove – Garden of Eden)
  - d) L2 – L4 (Sophia – Golden Grove and New Sophia – Golden Grove)
  - e) L17 – L5 (Good Hope – Columbia and Sophia – Kingston)
  - f) L20 – L5 (Columbia – Onverwagt and Sophia – Kingston)
  - g) L22 – L16 (Canefield – No. 53 and New Sophia – Good Hope)
- 3 N-1-1 (maintenance outage followed by a fault) to include:
  - a) L5 – L16 (Sophia – Kingston and New Sophia – Good Hope)
  - b) L5 – LS6 (Sophia – Kingston and Kingston – Vreed-en-Hoop submarine cable)
  - c) L3 – L4 (Golden Grove – Garden of Eden and New Sophia – Golden Grove)
  - d) L17 – L5 (Good Hope – Columbia and Sophia – Kingston)
  - e) L16 – L22 (New Sophia – Good Hope and Canefield – No. 53)

- 4 Extreme-Event outages to model:
  - a) Kingston substation failure
  - b) New Sophia substation failure (69 kV portion only)
  - c) Vreed-en-Hoop substation failure
  - d) Canefield substation failure
  - e) Skeldon substation failure

Violations noted, either from system-normal power flows or from contingency power flows, were mitigated and noted in Table 5.2 as 'reconductor', 'add new Static VAR Compensator (SVC)', 'N-1', or 'N-2' mitigations requiring a significant capital expenditure.

These general observations were noted in many of the 12 cases analyzed:

- 1 All loads were modeled with a power factor of approximately 90%. Consequently, as loads increased from 227 MW in 2023 to 331 MW in 2035, the system reactive power requirement increase caused numerous low bus voltages.
  - a) Low transmission-system voltages were mitigated by modeling various 5-MVAR shunt capacitor banks throughout the system
- 2 The radial 69 kV line Columbia – Onverwagt – Canefield – No. 53 – Skeldon was particularly affected as loads increased and Skeldon generation was decreased (due to generation dispatch favoring renewables and the gas plant). That part of the system tended to go into voltage collapse for year 2035 load levels and zero Skeldon generation. Additionally, the Columbia to Canefield line sections became overloaded.
  - a) Thermal overloads were mitigated by reconductoring the Columbia – Onverwagt – Canefield 69 kV line to 1-927 AAAC Greely conductor
  - b) Voltage collapse was mitigated by placing a 10-MVAR SVC at Canefield and another at Skeldon (in addition to the aforementioned numerous 5-MVAR shunt cap banks along that radial line to Skeldon)

Transmission system losses increased slightly from 2023 to 2035. In the 2023 cases the system losses were 8.6 MW at peak load, or about 3.8% of the total system load. In the 2035 cases the losses were 14.8 MW at peak load, or about 4.5% of the total 2035 system load.

Figure 16.2: 2035 PSS/E Model One-Line Diagram Example

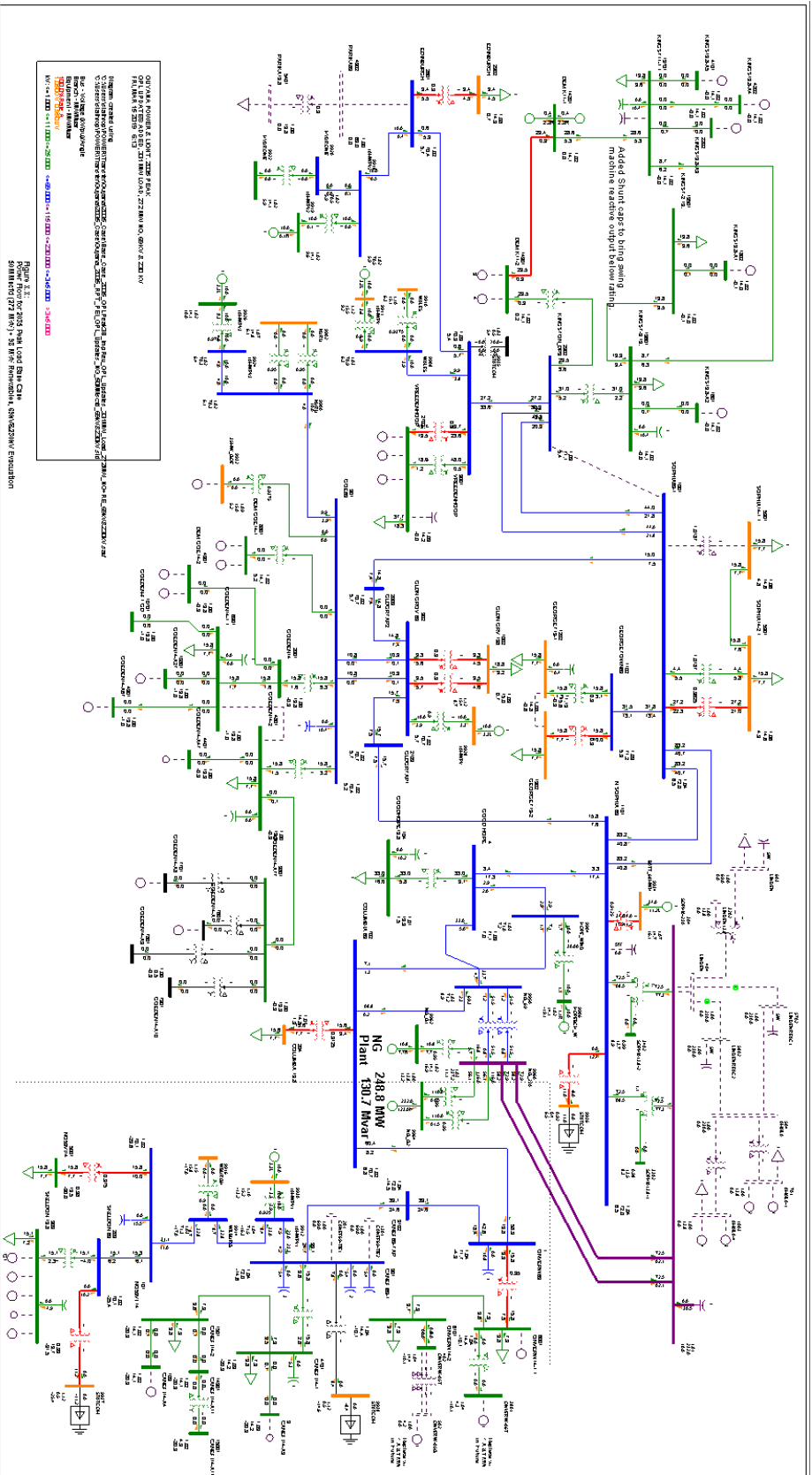

Source: K&M

Note

230 kV = Purple; 69 kV = Blue; 13.8 kV = Green; <13.8 kV = Black; Voltage Violation = Orange; Thermal Overload = Red; Dashed = Out-of-Service



Figure 16.4: 230 kV Only Interconnection Detail Example

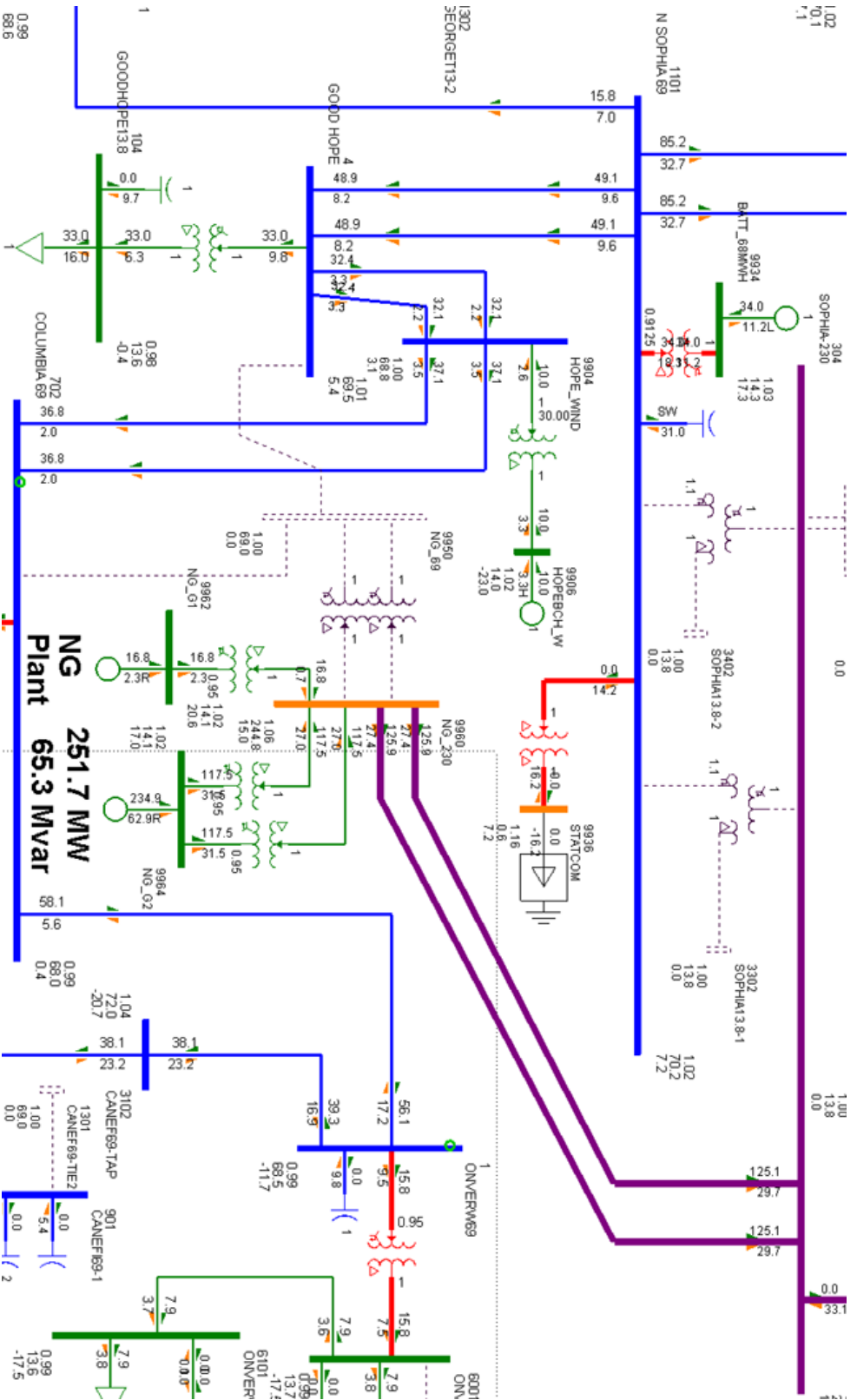

Note

230 kV = Purple; 69 kV = Blue; 13.8 kV = Green; <13.8 kV = Black; Voltage Violation = Orange; Thermal Overload = Red; Dashed = Out-of-Service

**Figure 16.5: 69 kV and 230 kV Interconnection Detail Example**

Source: K&M - Power Engineers

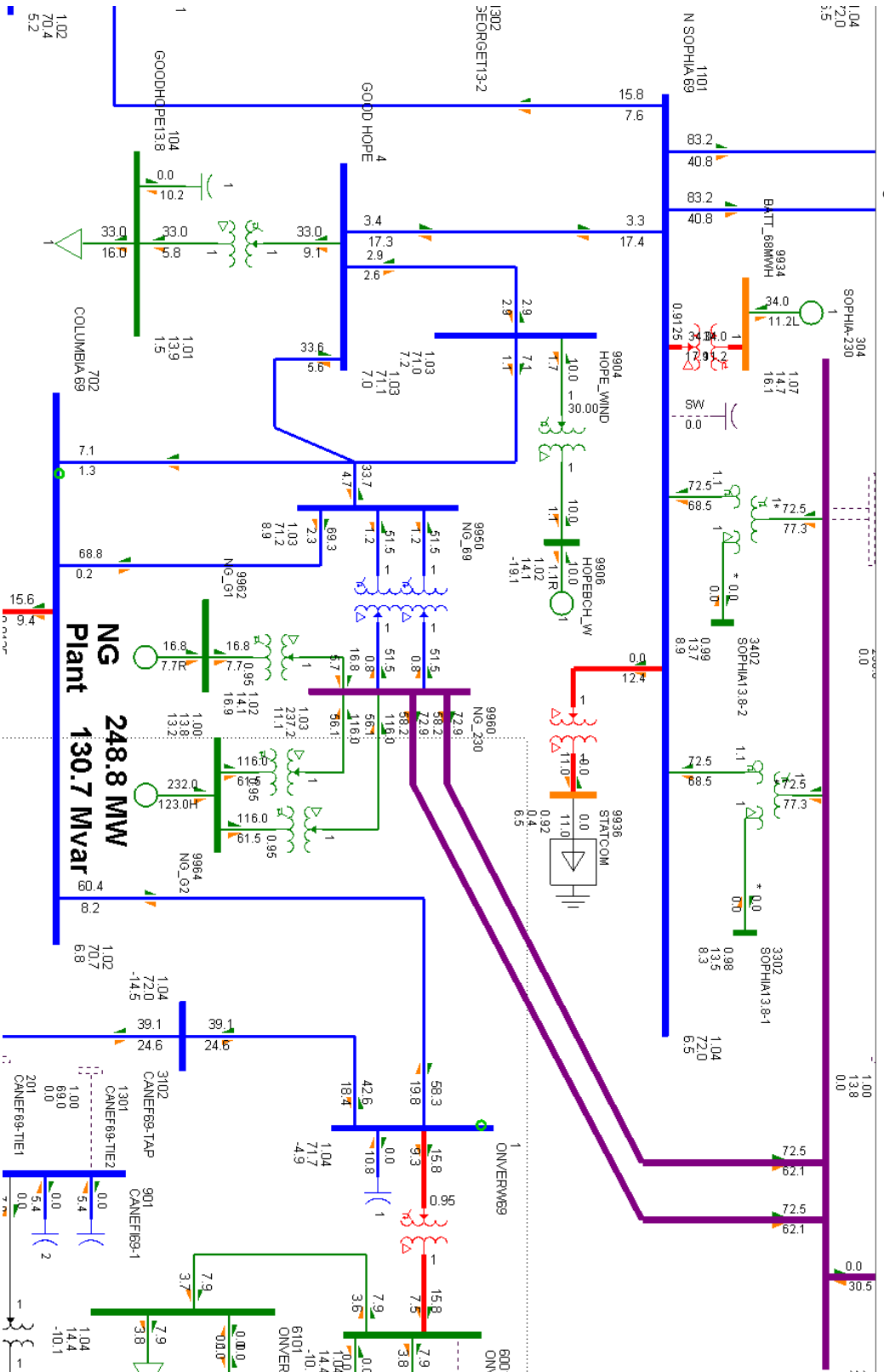



**Table 16.2: Summary of major Grid Interconnection Costs to Enable Gas Plant Evacuation**

Grid New Construction Cost Summary				
All costs in US\$				
Gas Supply Scenario	30 MMscfd		50 MMscfd	
Grid Coincidental Peak Load (MW): Year 2023   Year 2035	227	331	227	331
Gas Plant Peak Output (MW): Year 2023   Year 2035	170	170	200	272
69 kV Evacuation Only				
Costs Independent of a Site Location				
I. Gas Plant Interconnection Substation: 69 kV, 5 Line Positions 30 MM, 6 positions 50 MM	10,600,000		12,300,000	
II. Line Tap Switching Station, 69 kV, 6 km from New Plant on L17, 3 Line Positions 30 MM, 5 positions 50 MM	7,200,000		10,600,000	
III. 2 New 6-km, 69 kV Lines, New Plant – New Line Tap SW Sta. , 1-927 AAAC Greely per phase for 30MM, 2-927 per phase for 50MM	5,700,000		6,800,000	
IV. Reconductor L16, N. Sophia – Good Hope, 9.9 km, 1-927 30 MM, 2-927 50 MM	1,200,000		1,400,000	
V. New 69 kV line to Parallel L16, 2-927 AAAC per phase, 9.9 km			4,700,000	
VI. Reconductor L17, Good Hope – NG Tap – Columbia, 2-927 AAAC Greely per phase, 26.6 km			3,800,000	
VII. New 69 kV Line to Parallel L17, Good Hope – Columbia, 26.6 km, 1-927 30 MM, 2-927 50 MM	12,500,000		15,000,000	
VIII. Reconductor L20, Columbia – Onverwagt, 69 kV, 1-927 AAAC Greely, 37.18 km			4,500,000	
IX. Reconductor L21, Onverwagt – Canefield, 69 kV, 1-927 AAAC Greely, 41.32 km			5,000,000	
X. New 10 MVAR SVC, Canefield Substation	6,000,000		6,000,000	
XI. New 10 MVAR SVC, Skeldon Substation			6,000,000	
XII. N-1 Contingency Overload: Reconductor 13 km of L17, 69 kV, Good Hope – Hope Wind Tap, 1-927 AAAC Greely per phase	1,600,000			
XIII. N-1 Contingency Overload: Reconductor 0.177 km L12 69 kV Line, Sophia – N. Sophia, 2-927 AAAC Greely per phase	26,000		26,000	

## Grid New Construction Cost Summary

All costs in US\$

Gas Supply Scenario	30 MMscfd	50 MMscfd
XIV. N-1 Contingency Overload: Reconductor 0.177 km L13 69 kV Line, Sophia – N. Sophia, 2-927 AAAC Greely per phase	26,000	26,000
XV. N-2 Contingency Overload: Reconductor Line 5P, 69 kV increase capacity to at least 125 MVA, 5 km		720,000
<b>Costs Dependent on a Site Location</b>		
I. 2 New 69 kV Lines, 15 km, Gas Plant – N. Sophia, 1-927 AAAC Greely per phase		34,000,000
II. New 69 kV Line, 15 km, Gas Plant – N. Sophia, 2-927 AAAC Greely per phase	17,000,000	
<b>Total, 69 kV Evacuation Only</b>	<b>61,852,000</b>	<b>110,872,000</b>
<b>230 kV Evacuation Only</b>		
<b>Costs Independent of a Site Location</b>		
I. Interconnection Substation: 2 Line Positions	5,500,000	5,500,000
II. New N. Sophia 230 kV Switchyard, 4 Line Positions	8,900,000	8,900,000
III. New N. Sophia 230-69 kV Substation, 4 Line Positions, 2-155 MVA Transformers for 30MM, 2-283 MVA Transformers for 50MM	13,900,000	14,500,000
IV. Reconductor L16, N. Sophia – Good Hope, 1-927 AAAC Greely per phase, 9.9 km	1,200,000	1,200,000
V. Reconductor L20, Columbia – Onverwagt, 69 kV, 1-927 AAAC Greely, 37.18 km	4,500,000	4,500,000
VI. Reconductor L21, Onverwagt – Canefield, 69 kV, 1-927 AAAC Greely, 41.32 km	5,000,000	5,000,000
VII. Parallel L16, 69 kV, 1-927 AAAC Greely, 9.9 km	4,700,000	4,700,000
VIII. Parallel L17, 69 kV, 1-927 AAAC Greely, 26.6 km	12,500,000	12,500,000
IX. New 10 MVAR SVC, Canefield Substation	6,000,000	6,000,000
X. New 10 MVAR SVC, Vreed-en-Hoop Substation	6,000,000	6,000,000
XI. N-1 Contingency Overload: Reconductor L12, 69 kV increase capacity to at least 130 MVA, 0.16 km		23,000
XII. N-1 Contingency Overload: Reconductor L13, 69 kV increase capacity to at least 130 MVA, 0.16 km		23,000

## Grid New Construction Cost Summary

All costs in US\$

Gas Supply Scenario	30 MMscfd	50 MMscfd
XIII. N-2 Contingency Overload: Reconductor Line 5P, 69 kV increase capacity to at least 125 MVA, 5 km		720,000
<b>Costs Dependent on a Site Location</b>		
I. New 230 kV line, Gas Plant – N. Sophia, 1-927 AAAC Greely, 15 km	10,400,000	10,400,000
II. 2 <sup>nd</sup> 230 kV line, Gas Plant – N. Sophia, 1-927 AAAC Greely, 15 km	10,400,000	10,400,000
Total, 230 kV Evacuation Only	<b>89,000,000</b>	<b>90,366,000</b>
<b>69 kV and 230 kV Evacuation</b>		
<b>3 Costs Independent of a Site Location</b>		
I. New N. Sophia 230 kV Switchyard, 4 Line Positions Interconnection Substation: 2-200 MVA 230-69 kV Transformers; 4 Line Positions	12,300,000	12,300,000
II. New N. Sophia 230 kV Switchyard, 4 Line Positions	8,900,000	8,900,000
III. New N. Sophia 230-69 kV Substation, 2-155 MVA Transformers, 4 Line Positions	13,900,000	13,900,000
IV. Parallel L17, 69 kV, 1-927 AAAC Greely, 26.6 km	12,500,000	12,500,000
V. Reconductor L20, Columbia – Onverwagt, 69 kV, 1-927 AAAC Greely, 37.18 km	4,500,000	4,500,000
VI. Reconductor L21, Onverwagt – Canefield, 69 kV, 1-927 AAAC Greely, 41.32 km	5,000,000	5,000,000
VII. N-1 Contingency Overload: Reconductor 0.177 km L12 69 kV Line, Sophia – N. Sophia, 2-927 AAAC Greely per phase		26,000
VIII. N-1 Contingency Overload: Reconductor 0.177 km L13 69 kV Line, Sophia – N. Sophia, 2-927 AAAC Greely per phase		26,000
IX. N-2 Contingency Overload: Reconductor Line 5P, 69 kV increase capacity to at least 125 MVA, 5 km		720,000
X. New 10 MVAR SVC, Canefield Substation		6,000,000
<b>4 Costs Dependent on a Site Location</b>		
I. I. New 230 kV line, Gas Plant – N. Sophia, 1-927 AAAC Greely	10,400,000	10,400,000

Grid New Construction Cost Summary		
All costs in US\$		
Gas Supply Scenario	30 MMscfd	50 MMscfd
II. II. 2nd 230 kV line, Gas Plant – N. Sophia, 1-927 AAAC Greely	10,400,000	10,400,000
Total, 69 kV and 230 kV Evacuation	<b>77,900,000</b>	<b>84,672,000</b>

Source: K&M

**Note**

- 5 All costs in 2019 USD
- 6 AFUDC not included
- 7 Overhead costs not included
- 8 Contingency costs not included
- 9 Land or ROW acquisition costs not included
- 10 All 69 kV construction (lines and substations) is to be 115 kV construct, 69 kV operate
- 11 \$471,000/km for 1/C 115/69 kV line construction costs
- 12 \$565,200/km for 2/C 115/69 kV line construction costs
- 13 \$119,876/km for 1/C 69 kV reconductor costs
- 14 \$143,840/km for 2/C 69 kV reconductor costs
- 15 Reconductor costs assume line work is performed on de-energized circuits
- 16 \$691,072/km for 230 kV line construction

## 16.1 Grid Impact Conclusions and Recommendations

Plant output evacuation of up to 331 MW can be achieved at either voltage level studied, for the system topology and contingencies analyzed. Evacuating lower plant output levels over a 69 kV-only system results in a significant CAPEX savings compared to the other two alternatives studied. At higher plant output evacuation levels, a combination 69 kV and 230 kV presents the lowest CAPEX cost.

The downside of a 69 kV-only option is that the resulting transmission system is not amenable to interties with neighboring countries or with the Arco-Norte interconnection—this limits the system future expansion capability.

A 230 kV-only option is the costliest for the 30 MM scfd gas supply level and is not recommended for that gas plant size. The 69 kV-only option is the costliest for the 50 MM scfd gas supply level and is not recommended for that gas plant size.

The least-costly grid impact for a 30 MM scfd plant is the 69 kV-only option. The least-costly grid impact for a 50 MM scfd plant is the combined option: 69 kV and 230 kV, staged.

K&M recommends that GPL construct a 69 kV-only evacuation system for initial (lower) plant output, over a single 1-927 AAAC line constructed between Good Hope and Columbia (constructed at 115 kV insulation, clearance and strength), and a single 69 kV line (constructed at

230 kV insulation, clearance and strength) between the plant and New Sophia. When those line capacities are projected to be reached, the 230 kV evacuation system should be constructed to augment the 69 kV system.

K&M further recommends that any 69 kV infrastructure built be constructed at 115 kV insulation, clearance and strength levels, but operated at 69 kV until a voltage conversion occurs. Additionally, system reliability is increased if multiple transmission/distribution circuits do not share the same poles (e.g.: double circuits). Unless rights-of-way are difficult or expensive to obtain, it is recommended that multiple circuits between substations are constructed as separate pole lines separated by a distance of at least one span length.

**Table 16.3: Summary of Grid CAPEX Investment Scenarios (all values in US\$)**

Evacuation System Buildout Voltage Level	170 MW, 30 MMscfd Investment Level	272 MW, 50 MMscfd Investment Level
69 kV Only	61,852,000	110,872,000
230 kV Only	89,000,000	90,366,000
69kV and 230 kV	77,900,000	84,672,000

## 17 Terms of Gas Supply Agreement

There are two possible arrangements for the gas supply to the Project:

- IPP enters into direct Gas Supply Agreement (GSA) with a gas supplier and GPL has a Power Purchase Agreement with IPP for purchase of capacity and energy;
- Gas is supplied to IPP by GPL at no cost with GPL entering into a GSA with a gas supplier and Energy Conversion Agreement (ECA) with IPP.

The terms of the GSA between either IPP or GPL on one side and a gas supplier on another side are going to be similar for both options. Though there are some differences gas supply in how the gas supply risks are allocated between the IPP and GPL under the PPA and ECA.

The major differences are presented in Table 17.1 below:

**Table 17.1: PPA and ECA Gas Supply Risk Allocations**

No.	Provisions	Risk Allocation	
		PPA	ECA
1	Take or Pay. The gas supplier will include a minimum gas quantity that gas purchaser will have to take annually with gas purchaser paying for this minimum quantity even if it is not taken.	Risk is passed to GPL under PPA electricity take or pay provisions so that GPL will have to dispatch the plant to generated certain minimum number kWh per year or pay for this minimum quantity even it not taken. GPL can control this risk as they control plat dispatch.	This risk is assumed and controlled by GPL as they control plant dispatch.
2	Gas consumption	Risk is assumed by IPP as they will be reimbursed under energy tariff base on their guaranteed heat rates and will absorb cost of additional fuel in case the actual hear rate is above the guarantee.	Risk is assumed by IPP as the quantity of fuel they should consume will be calculated based on their guaranteed heat rate and GPL will be reimbursed for the cost of fuel consumed in excess of the quantity calculated based on the heat rate guarantee.
3	Gas supply interruption	Risk is assumed by IPP. For interruptions caused by a gas supplier the risk will be passed to a gas supplier under the GSA.	Risk is assumed by GPL. For interruptions caused by a gas supplier the risk will be passed to a gas supplier under the GSA.
4	Gas quality	Risk is assumed by IPP. For gas quality deviations from specifications caused by a gas supplier the risk will be passed to a gas supplier under the GSA.	Risk is assumed by GPL. For gas quality deviations from specifications caused by a gas supplier the risk will be passed to a gas supplier under the GSA.

No.	Provisions	Risk Allocation	
		PPA	ECA
5	Gas supply infrastructure construction schedule	Gas infrastructure schedule risk is assumed by IPP.	Gas infrastructure schedule risk is assumed by GPL unless IPP scope of work does not include construction of gas supply infrastructure.

Provisions of the GSA will largely remain the same regardless of whether gas is purchased by IPP directly from a gas supplier or supplied to IPP by GPL who will enter into GSA with a gas supplier.

For the Gas Supply Agreement (GSA), under any of the above scenarios K&M recommends to first negotiate the material terms and conditions, technical and commercial, in a term sheet which can be later used as a guide for the legal counsels of both parties to prepare the proposed final agreement.

A preliminary version of a term sheet with the main clauses of the gas supply agreement prepared by K&M is presented as Appendix C to this document.

K&M reviewed the model contract gas supply agreement issued by AIPN (Association of International Petroleum Negotiators) 2006 version that was received from Exxon Mobil.

Regarding the type of contract, K&M recommends a bankable 25-year firm take-or-pay gas supply contract with fixed and Henry Hub-indexed price components and delivery point at the Plant site. In case the gas producer would only produce natural gas for Guyana domestic market and not plan to export it to other regional consumers in form of LNG or compressed gas, the non-fixed price component and its indexation could be negotiated between the producer and GoG with indexation not based on Henry Hub, but on US CPI or other index that reflects producers' variable cost of natural gas production. The AIPN contract model is an acceptable base to start from when the GoG gets to the drafting of a complete contract.

A preliminary assessment of the gas fuel supply contract risks and proposed mitigation measures is presented as Appendix D to this document.

## 18 Regulatory Framework Review

---

The purpose of this section, as required by the scope described in the terms of reference of the study, is to review and recommend the required regulatory framework for the natural gas power plants to be operational. With this in mind, this section will not review the institutional framework or high level policies and strategies for the energy sector, such as the draft National Energy Policy of Guyana Green paper and others which have been discussed by other consultants in previous studies, but intends to provide practical recommendations focused on the identification of any regulations that are currently missing in Guyana that would have to be developed or updated for safe and efficient operation of natural gas power generation plants in the country.

The regulatory framework applicable to fossil-fueled power generation plants in Guyana is supported by five main duly sanctioned documents from which other lower rank regulations and guidelines are derived:

- a) The Petroleum (Exploration and Production) Act 1986
- b) The Electricity Sector Reform Act 1999, amended in 2010
- c) The Guyana Energy Agency Act 1997
- d) The Public Utilities Commission Act
- e) The Environmental Protection Act 1996

The following sections a review of the content of the above-mentioned regulatory framework as well as recommendations on additional that would be applicable to gas-fired power plants only.

### 18.1 Review of existing regulatory framework

#### 18.1.1 Petroleum (Exploration and Production) Act 1986

This legislative document, the Act No. 3 of 1986, applies to the exploration, exploitation, conservation, and management of petroleum existing in its natural condition in land in Guyana, including the territorial sea, continental shelf and exclusive economic zone of Guyana.

Petroleum under this Act also includes natural gas, since it is defined as any naturally occurring hydrocarbons, or mixture of hydrocarbons whether in a gaseous, liquid, or solid state (except for coal, shale, or any substance that may be extracted from coal or shale).

This act is composed by the following ten parts: Part I Preliminary, which includes applicable definitions for interpretation; Part II Administration; Part III Regulation of prospecting for production of petroleum; Part IV Licenses, which describes all aspects related with petroleum prospecting license, petroleum production license, unit development, restrictions for licensees and cancellation of license; Part V Financial, which stipulates the royalties on petroleum obtained under license and related matters; Part VI Modification of tax laws; Part VII Restriction on rights of licensee and surface rights; Part VIII Miscellaneous, which includes permission for geological or geophysical surveys, power of entry, penalties, indemnifications, among other stipulations; Part IX Regulations, and Part X Repeal.

In Part IX Regulations, Section 70, the Minister is entitled to make regulations for carrying out the purposes of the act, including among others, the following items directly related with the use of petroleum (including natural gas as part of the general definition of petroleum): (e) the



construction, erection, maintenance, operation or use of installations, machinery or equipment; (f) the control of the flow and the prevention of the escape of petroleum, water, gases (other than petroleum) or other noxious or deleterious matters; (l) the methods to be used for the measurement of petroleum, water and other substances from a well; (m) safety and welfare standards, and the health and safety of persons employed in or in connection with the prospecting for, or the production or conveyance of petroleum.

### **18.1.2 Electricity Sector Reform Act**

This legislative document, the Act No. 11 of 1999, is composed by the following parts: Part I Preliminary, which includes the applicable definitions for interpretation; Part II Electricity supply, which includes the requirements and stipulations related to license for the supply of electricity; Part III Reform of the electricity sector, which includes the creation of Guyana Power & Light, and stipulations for the construction or expansion of installations or capacity for electricity generation; Part IV Miscellaneous and supplemental provisions, including liabilities and immunities of suppliers and others, penalties, duties of the Minister, and authority to make regulations, among other subjects. This Act also includes three schedules: a First Schedule providing the rates for the supply of electricity and services and the rate adjustment mechanism; a Second Schedule, with the electricity and service rates notice; and a Third Schedule with public electricity supply regulations.

### **18.1.3 Guyana Energy Agency (GEA) Act 1997**

This legislative document, the Act No. 31 of 1997, amended by Act No. 17 of 2010, is composed of four main parts: Part I Preliminary, which includes the interpretation; Part II Guyana Energy Agency, which describes the organic structure, functions, procedures, funding and resources of the agency; Part III Energy Agency Board, which describes the organic structure, functions, procedures and preservation of secrecy of the Board; and Part IV Miscellaneous, which describes some powers of the Minister in regard to the Agency among other aspects.

### **18.1.4 Public Utilities Commission (PUC) Act**

This legislative document, the Act No. 29 de 1997, is composed of the following parts: Part I Preliminary, which includes the scope of application and definitions for interpretation; Part II Public utilities commission, which establishes the PUC and stipulates term, emoluments, conflicts of interests, and procedures, among other topics; Part III Officers and employees; Part IV Budget and resources; Part V Functions of the commission; Part VI Service and facilities; Part VII Development and expansion of facilities and services; Part VIII Rates, including principles and change of rate; Part IX Other regulatory provisions; Part X Procedure; Part XI Funding of the commission and costs; Part XII Enforcement of orders; Part XIII Offences and penalties; Part XIV review and appeal; and Part XV Miscellaneous, which describes duties of public utilities to cooperate and furnish information to the PUC, annual reports, and the powers of the PUC to make rules, and the Minister to make regulations.

### **18.1.5 Environmental Protection Act 1996**

This legislative document, the Act No. 11 of 1996, is composed of three parts: Part I Preliminary, which includes the applicable definitions; Part II General, which includes stipulations regarding Environmental Impact Assessment, records, reports to the Agency, conditions for environmental authorization and monitoring; and Part III Power to grant environmental authorization, which

describes several aspects related with environmental authorizations such as: applications requirements, granting powers, duration, application for changes, transfer, and renewal.

## **18.2 Recommendations on regulatory framework**

### **18.2.1 Electricity regulations**

K&M reviewed the GPL National Grid Code and found that its structure and most of its content, which is currently being used to regulate the operation of existing liquid fuel power plants, will be also applicable to the operation of the new gas-fired power plant. As indicated in the implementation roadmap presented in section 19, after the new plant construction project is awarded and the specifications of the new units are confirmed by the selected original equipment manufacturer (OEM), a full interconnection study request (FISR) will be submitted by the project company as interconnecting customer (IC) to GPL's approval prior to construction. Based on the results of such study and GPL's comments, an update to the GPL National Grid Code will be required, given that the existing capacity figures indicated in section 2.13.1 of current Grid Code as well as other considerations will be affected by the new project and changes in the grid topology.

Apart from an update of the National Grid Code as indicated above no substantial changes are required on current electric sector regulations to make new gas-fired power plants operational. For future revisions of the National Grid Code it is recommended to avoid the use of specific values which may be subject to variation with incorporation of new interconnecting customers to the grid.

### **18.2.2 Environmental regulations**

Most of the regulations for existing HFO generating plants are also applicable to gas-fired generating units, except for air emissions which should have limits stipulated for gas-fired power plants. K&M reviewed the regulatory section in the Guyana Environmental Protection Agency website (<http://www.epaguyana.org/epa/downloads/regulations>) and found that, as of March 2019, the Environmental Protection (Air Quality) Regulations 2000 as well as other regulations published there appear to be still in draft version and do not contain specific limits, but institutional framework and general requirements.

To ensure that the environmental and social impacts to the natural habitat caused by the new gas-fired power plant and associated infrastructure will be addressed in accordance with international practices acceptable to international lending organizations, the IFC's (International Finance Corporation) Performance Standards on Environmental and Social Sustainability<sup>17</sup> will have to be used to as reference for assessing environmental compliance during project development, construction and operation. This, among others, will require preparation of the Environmental and Social Impact Assessment (ESIA) in accordance with the IFC Performance Standard requirements.

---

<sup>17</sup> [https://www.ifc.org/wps/wcm/connect/115482804a0255db96fbffd1a5d13d27/PS\\_English\\_2012\\_Full-Documents.pdf?MOD=AJPERES](https://www.ifc.org/wps/wcm/connect/115482804a0255db96fbffd1a5d13d27/PS_English_2012_Full-Documents.pdf?MOD=AJPERES)

For the air emissions, effluent water, and noise emission limits the IFC's Environmental, Health, and Safety Guidelines for Thermal Power Plants<sup>18</sup> are recommended to be used in absence of specific requirements set by the Guyana Environmental Protection Agency.

### 18.2.3 Fuel regulations

Although the Petroleum (Exploration and Production) Act 1986 sets the overall framework for hydrocarbon regulations in Guyana, there are no specific rules applicable to transportation, connections, and metering of natural gas. For the case of the new power plant project, the technical and commercial requirements can be agreed by the parties in the gas supply agreement, and recommendations in this regard were provided in Section 17. Note that in such case any additional requirements from future regulations would constitute a change of law for the purposes of the contracts and may be subject to equitable remedies or adjustments to the contract.

The approach of GSA specifying the connections, metering, fuel quality, and operational requirements for gas to power indicated above takes into consideration the fact that the Project will be the first gas-fired facility in the country and a single user with a dedicated gas pipeline. . In preparation for a future development and expansion of a natural gas system in the country under a concept of open access to third parties it is recommended that the GoG consider development of gas tariffs regulations for natural gas supply and transportation, as well as a specific body of rules applicable to natural gas in a separate regulatory document derivative from the existing Petroleum Act 1986. Such document should cover the following topics and sections presented as reference:

- 1 General Principles
  - a) Definitions
  - b) Objectives and scope
  - c) Institutional framework
- 2 Access and Connections
  - a) Dedicated gas pipelines
  - b) Access to gas pipelines
  - c) Title and division of responsibilities in connections, inlet and outlet points
- 3 Operation
  - a) Responsibility for operation and coordination
  - b) Nominations and balance accounts
  - c) Operation duties
  - d) Title and risk of loss on the gas

---

18

[https://www.ifc.org/wps/wcm/connect/dfb6a60048855a21852cd76a6515bb18/FINAL\\_Thermal%2BPower.pdf?MOD=AJPERES&id=1323162](https://www.ifc.org/wps/wcm/connect/dfb6a60048855a21852cd76a6515bb18/FINAL_Thermal%2BPower.pdf?MOD=AJPERES&id=1323162)

- e) Emergency management
- 4 Metering and invoicing
  - a) Metering and allocation of energy quantities in inlet and outlet points
  - b) Volume metering
  - c) Metering of other variables
    - i) Temperature
    - ii) Pressure
    - iii) Supercompressibility
    - iv) Specific gravity
    - v) Calorific power
  - d) Accuracy and calibration
  - e) Obligations of the parties
- 5 Quality and applicable standards
  - a) Applicable standards
  - b) Resolution of disputes regarding technical standards
  - c) Gas quality

## 19 Project Implementation Roadmap

---

A roadmap with the sequence of the main activities and timelines for the development of the new gas-fired power plant is presented in the end of this section. Based on the assumptions described below, K&M estimates the Project Phase 1 development and construction activities could be completed within 60 months for the IPP option and 54 months for the EPC option.

This project development schedule was prepared for a base case scenario considering the following assumptions:

- a) The project will be developed as an IPP
- b) The project will be developed in phases as indicated in Table 14.1 and Table 14.2
- c) No major regulatory changes would be required prior to implementation and contracts negotiations. If the GoG decides to develop, approve, and enforce a specific body of rules applicable to future development of a domestic market of natural gas prior to entering in to a GSA, then additional tasks and time would need to be considered in the roadmap.
- d) New Sophia is assumed as the connection substation due to GPL plans of having this substation as a hub for the network. The transmission interconnection line between the Project and New Sophia substation including expansion of the new Sophia substation will be included in the scope of the IPP.
- e) Gas processing plant and gas supply pipeline between the gas processing plant and the Project will be developed and constructed by others.

In case the GoG and GPL decides to implement the Project as a GPL-financed and owned Project executed by hiring an EPC Contractor, the Project development and procurement period and, as a result, the overall Project implementation period through commercial operation of Phase 1 is expected to shorten by approximately 6 months.

K&M anticipates that preparation of the full Environmental and Social Impact Assessment and obtaining environmental permit, electric interconnection study and obtaining other Project permits will be undertaken by the private investor in parallel with their financial close activities as completion of some those items will likely be a pre-condition for obtaining project financing.

K&M included potential land acquisition, negotiation of easements, and other pre-construction development activities to be developed by the GoG for the new plant and transmission line as part of the overall Project development schedule as this is one of the critical elements that would have to be completed on time to ensure the Project completes on schedule.

Land acquisition process was assumed to take place within six months, based on the assumption that the land of the selected site and right of ways for transmission lines is free of any ownership disputes.

Pre-construction activities include the engagement of a Transaction Advisor to assist the GoG with the following activities: project structuring and contractual risk allocation, GSA negotiations, IPP tendering process, PPA negotiations, and support during financial close by IPP contractor. Typical cost of transaction advisor that includes transaction, technical, and legal services associated with IPP procurement are around US\$ 2 million and vary from country to country depending on the scope and complexity of the project, existing regulatory environment, applicable taxes, etc.

The development schedule reflects GoG's intention of achieving commercial operation by 2023.

Based on K&M's experience, the typical construction schedule for a greenfield combined cycle gas turbine power plant or for RICE power plant with multiple engines from the notice to proceed to commercial operation date ranges between 24 and 36 months. This ultimately will depend on the market conditions for gas and steam turbines and other long lead items, location and characteristics of selected site, country specifics, etc. For this study K&M assumed that Phase 1 will reach commercial operation within 30 months from the notice to proceed given to the EPC Contractor (in IPP option this normally will occur after the Project reached financial close).

K&M estimates that the total duration required for Project implementation will be approximately 60 months for IPP option and 54 months for EPC option. The difference is caused by the additional time required for an IPP contractor to secure financing after the IPP contract is signed. Although in the IPP option schedule shows COD moved to 2024, K&M believes that it is still possible to reach COD in 2023 in case the IPP puts some equity at risk by issuing a limited notice to proceed with engineering to their EPC Contractor prior to achieving Financial Closing. This approach was observed by K&M on some of the previous IPP projects when IPP developers faced aggressive schedules .

Figure 19.1: Project Implementation Plan. IPP Option

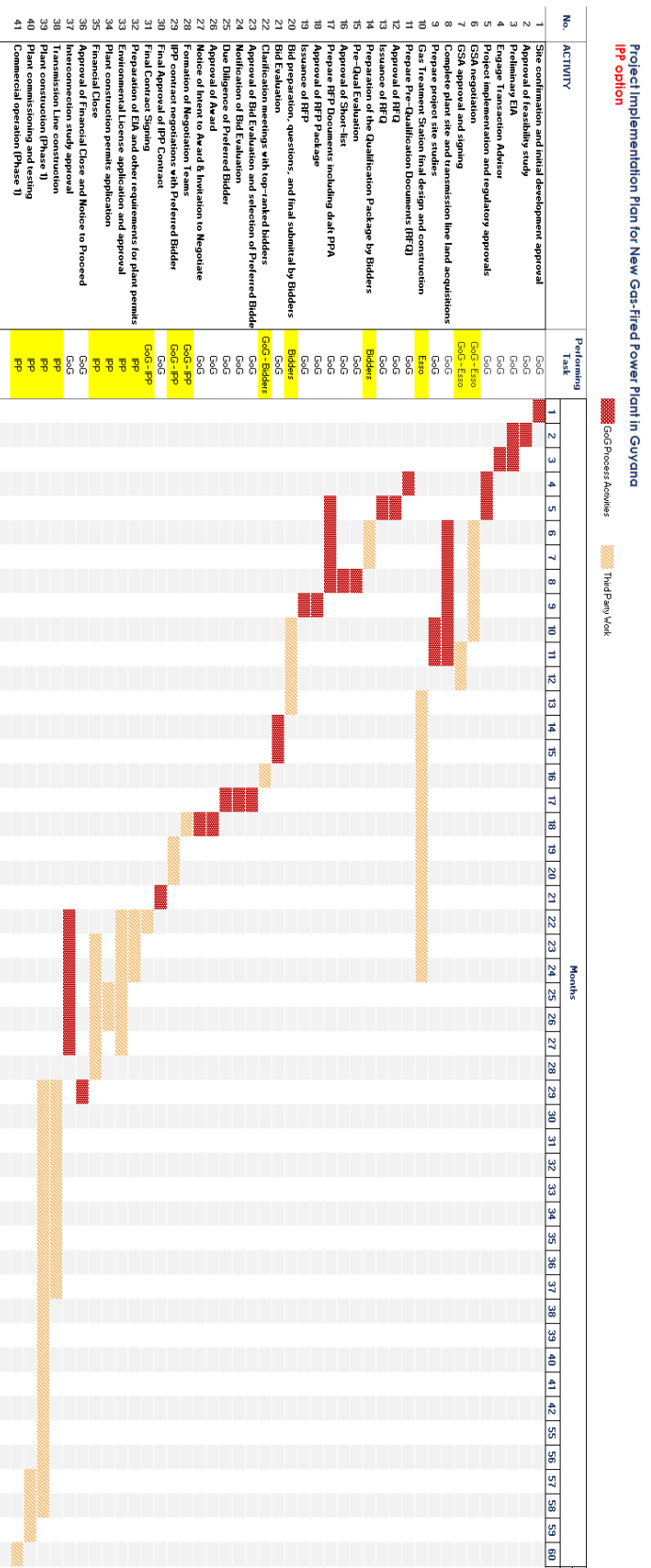
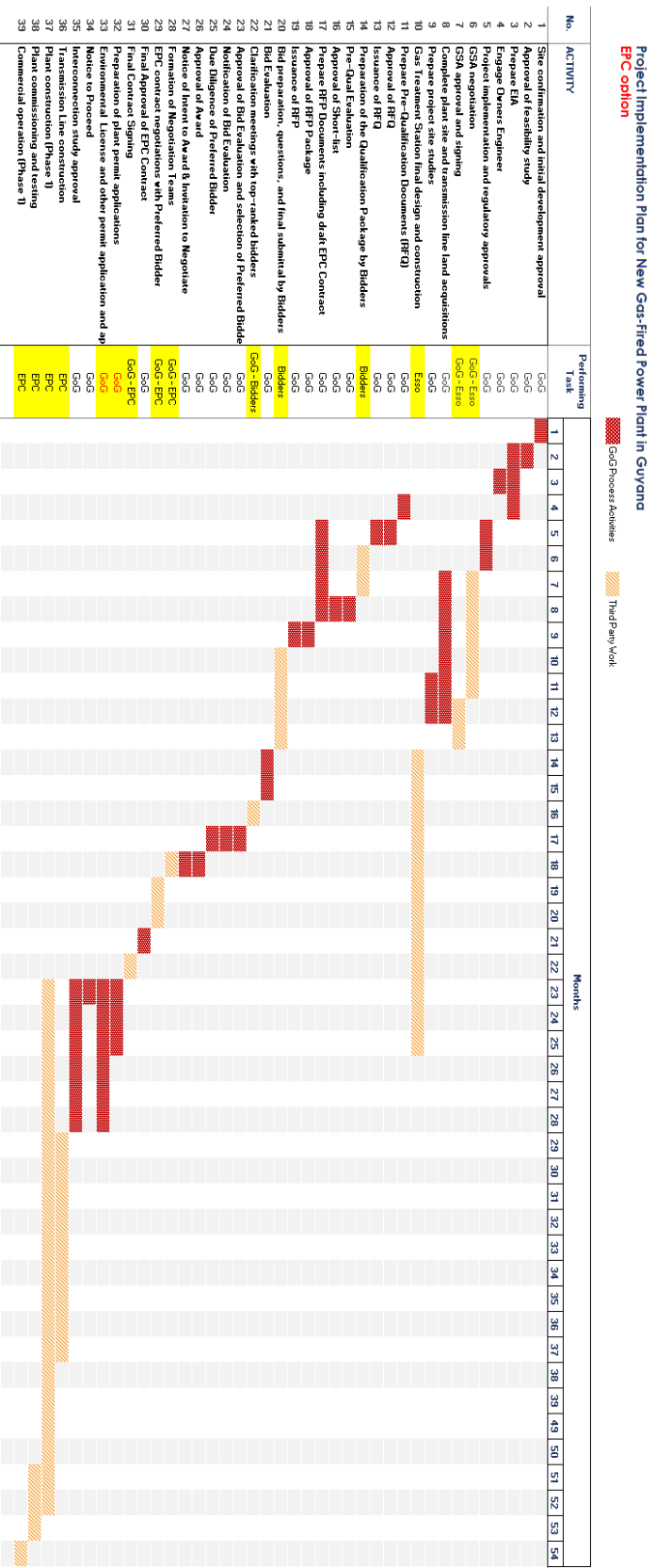

Figure 19.2: Project Implementation Plan. EPC Option





## 20 Conclusions

---

The following are the conclusions resulting from the results of the analysis performed in the above sections of the report.

- 1 The current installed capacity of 136.9 MW is not adequate to cover existing demand due to the low availability and planned retirements of existing units, transmission system constrains, and unserved demand that would connect to the grid if it has higher reliability of power supply.
- 2 DBIS system requires addition of at least 250 MW of new capacity by 2035 to satisfy growing electricity demand.
- 3 Additional HFO-based capacity will have to be installed by 2026 in case there are delays with development and construction of hydropower capacity for 30 MMscfd natural gas scenario.
- 4 Though it is likely that recoverable natural gas reserves will be sufficient to support required gas supply for both 30 MMscfd and 50 MMscfd over the useful life of new gas fired power plant, there is no reliable information regarding recoverable natural gas reserves in Stabroek field. Gas reserve information must be confirmed with the gas supplier prior to start of development of new gas fired power plant.
- 5 Increased penetration of solar generation will not impact the dispatch from the new power plant but will reduce the consumption of HFO generation.
- 6 Conversion of existing HFO units is not feasible due to high conversion costs and difficulties in transportation of natural gas to existing units
- 7 CCGT and RICE are the best two technology options for the new gas fired power plant.
- 8 Using natural gas as fuel for generating capacity additions will provide significant environmental benefits.
- 9 Using RICE technology results in slightly lower cost of electricity generated by the Project.
- 10 EPC option for Project implementation results in lower overall electricity cost and shorter implementation schedule but allocates more risks to GPL.
- 11 EPC option with DFI financing results in the lowest overall electricity cost, but increases the project implementation risk allocated to the GoG.
- 12 Injecting the new plant power output simultaneously to the Good Hope – Columbia 69 kV line and the 230 kV bus at the New Sophia substation seems to be an optimum solution.

## 21 Recommendations

---

- 1 K&M recommends using RICE technology for the new power plant as it results in slightly lower cost of electricity for majority of the options considered, higher fuel flexibility as it has the ability to run on lower cost HFO, and the loss of a single RICE unit will not cause a significant strain on the system due to its relatively lower unit size.
- 2 It is extremely important for the Government of Guyana to work with the prospective gas supplier to obtain firm quantity of available natural gas reserves for power generation.
- 3 The hydropower plant is expected to come online by 2026. Any delays in the construction of the hydropower plant will result in firm capacity deficits that would require additional HFO-based generation.
- 4 The new power plant will constitute a significant portion of Guyana's electricity generation and any disruption in supply of natural gas could significantly impact the cost and availability of electricity, especially in the case of higher gas supply volumes. This risk will be reduced if the Arco Norte transmission interconnection project is implemented.
- 5 The Government of Guyana should make a decision on whether the project should be implemented using IPP or EPC model based on cost, risk allocation and Guyana and GPL fiscal capacity considerations and Government's overall policy objectives related to inviting private sector participation in power industry.
- 6 K&M recommends the Government of Guyana to select an IPP developer or an EPC contractor using competitive bidding process and to engage an experienced Transaction Advisor (in case of IPP) or an Owner's Engineer (in case of EPC) to assist the Government of Guyana during the bidding process and project implementation.
- 7 The new power plant should be a multi-unit facility connected to the grid by a double circuit line, which mitigates the risk of losing the entire or significant portion of the facility with the loss of a single unit or one of the circuits.
- 8 K&M recommends that GPL construct a 69 kV-only evacuation system for initial (lower) plant output, over a single 1-927 AAAC line constructed between Good Hope and Columbia (constructed at 115 kV insulation, clearance and strength), and a single 69 kV line (constructed at 230 kV insulation, clearance and strength) between the plant and New Sophia. When those line capacities are close to reaching their limit, the 230 kV evacuation system should be constructed to augment the 69 kV system.
- 9 K&M recommends that any 69 kV infrastructure built be constructed at 115 kV insulation, clearance and strength levels, but operated at 69 kV until a voltage conversion occurs.
- 10 K&M recommends that unless rights-of-ways are difficult or expensive to obtain, multiple circuits between substations are constructed as separate pole lines separated by a distance of at least one span length to increase system reliability and resilience.





# Appendix B: Electrical Single-Line Diagrams

## B.1 Case 1 - RICE units (30 MMscfd)

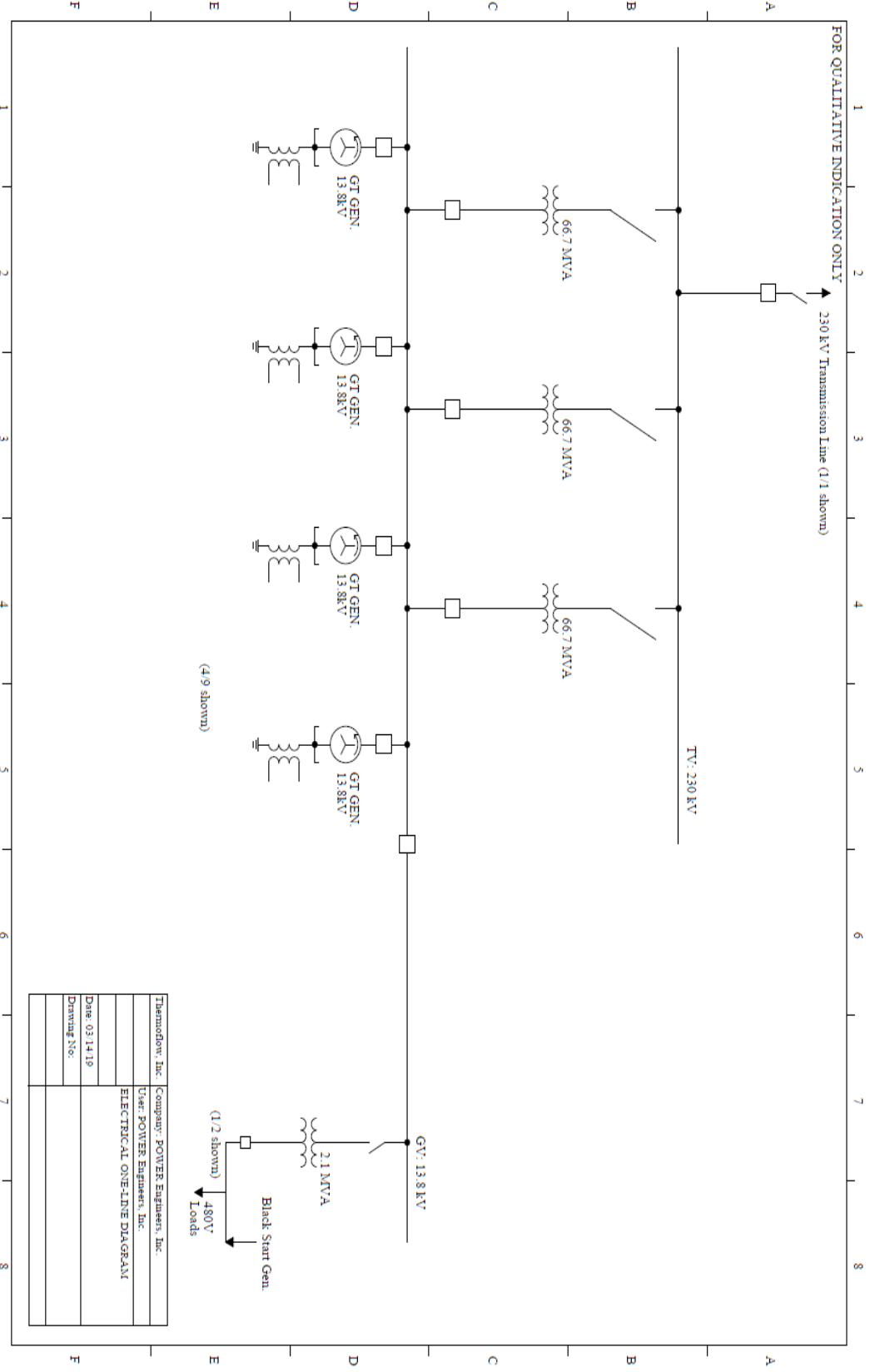

## B.2 Case 2 - RICE Units (50 MMscfd)

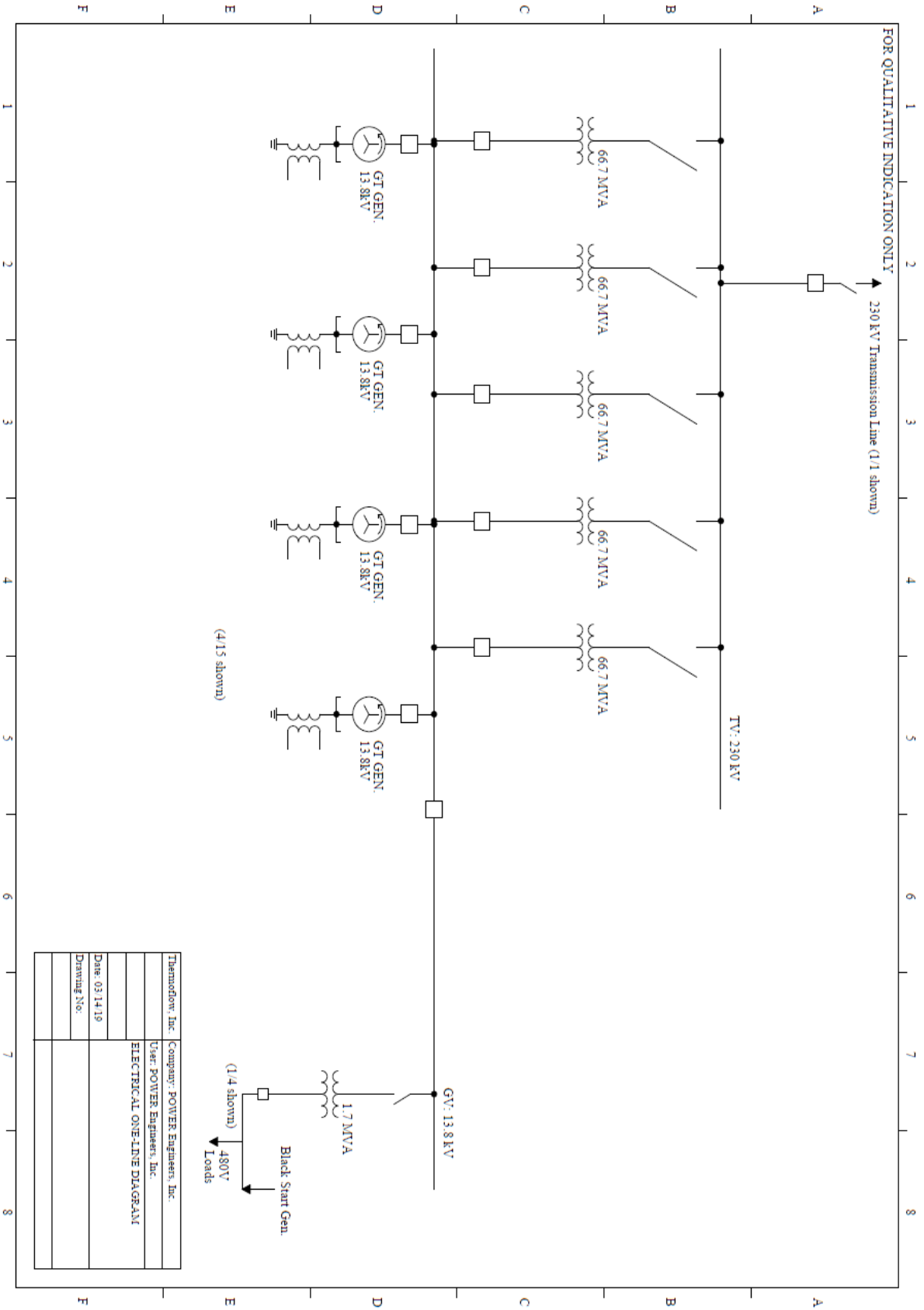

### B.3 Case 3 - Combined Cycle Gas Turbine units (30 MMscfd)

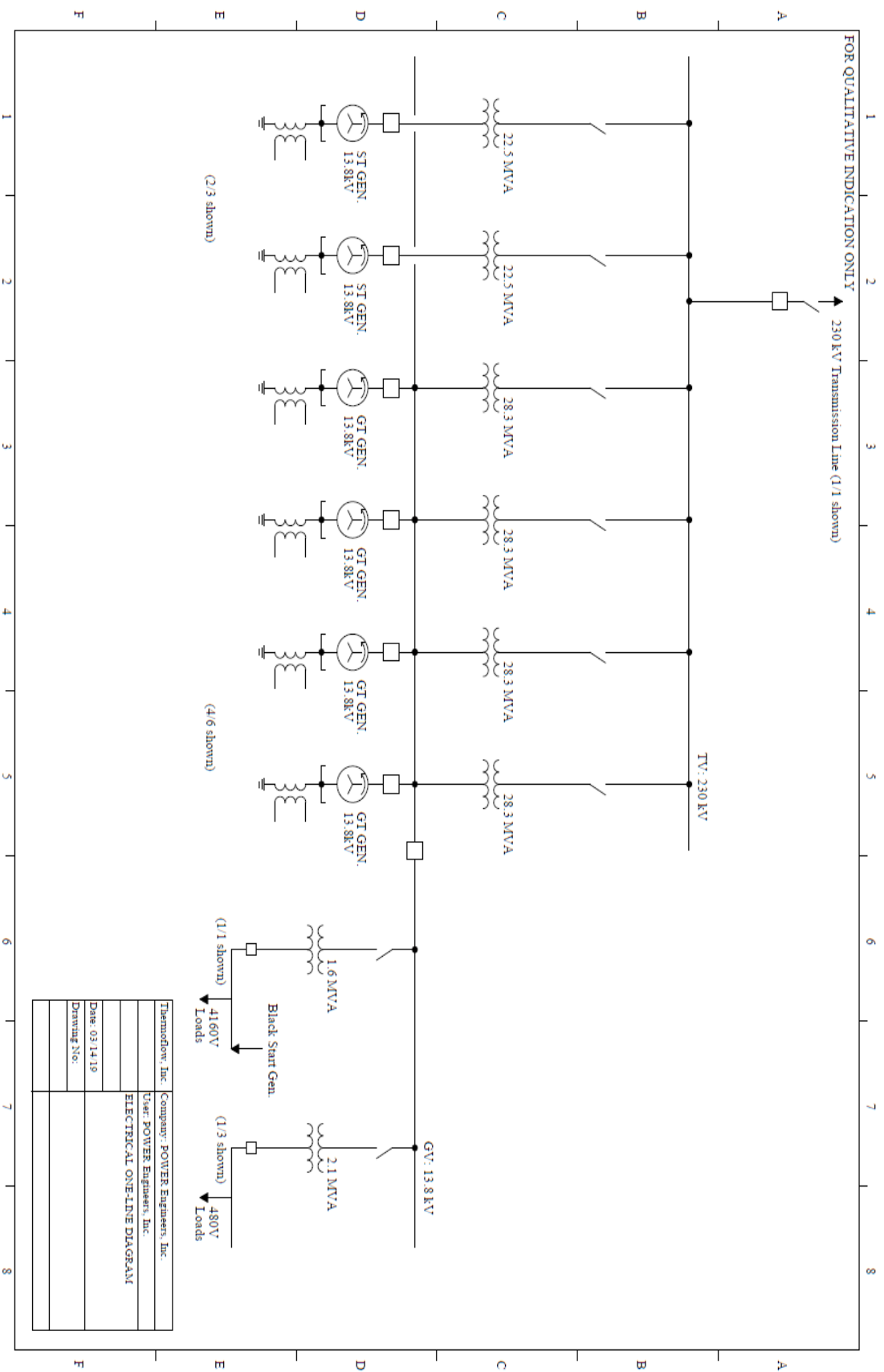

## B.4 Case 4 - Combined Cycle Gas Turbine Units (50 MMscfd)

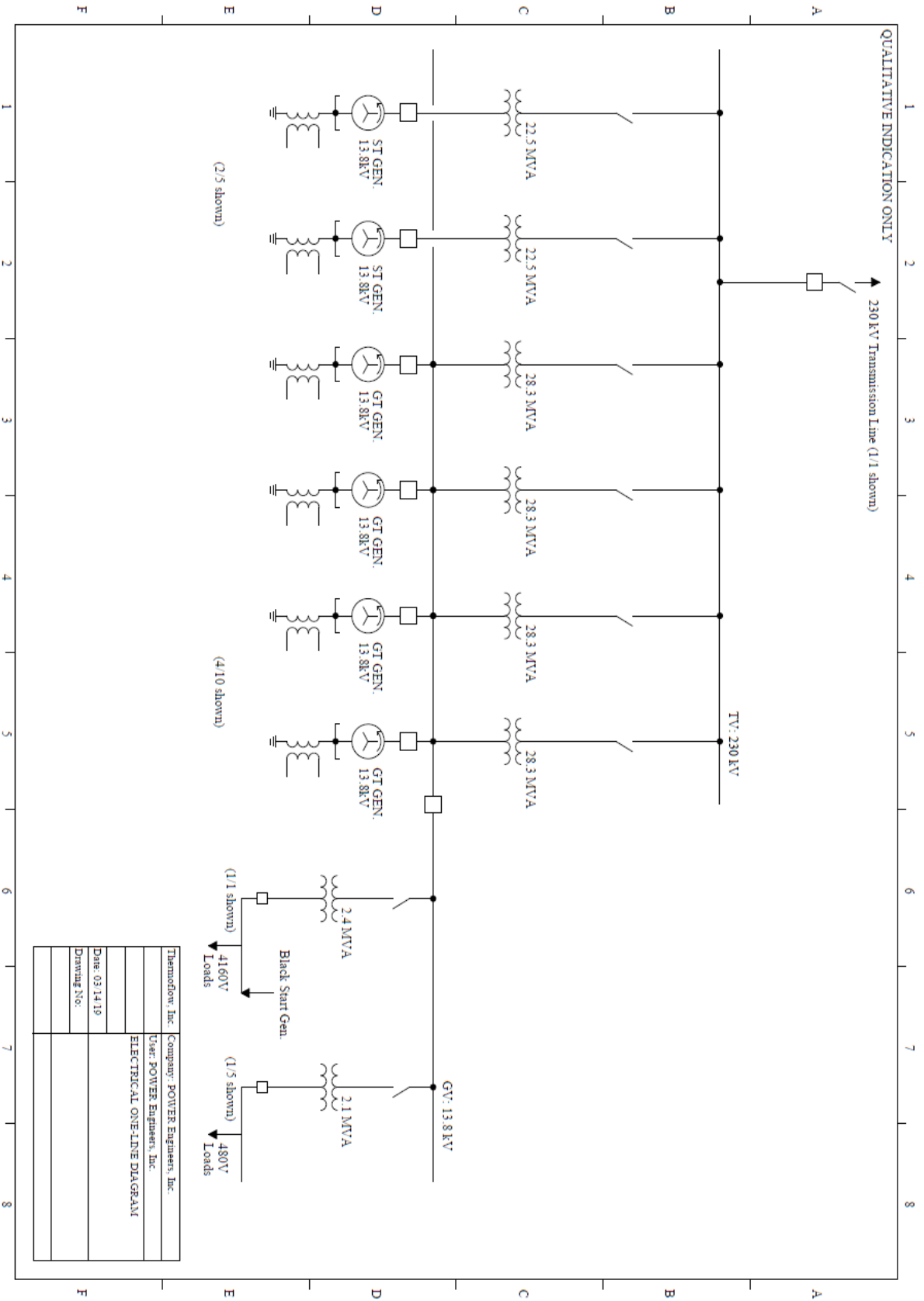



## Appendix C GSA Term Sheet

Article	Provisions
<b>Contracting Parties</b>	[Affiliate/consortium Company] ("Seller"), and the [company owning the power plant] ("Buyer"). Seller and Buyer collectively referred to as the "Parties".
<b>Contract Purpose</b>	Establish the terms and conditions under which Seller will supply natural gas to the Buyer at the Delivery Point for use in the Plant (as defined hereafter).
<b>Key Definitions</b>	<p>"Agreement" or "GSA" means this Agreement governing, among other things, the supply and sale of natural gas from Seller to Buyer.</p> <p>"Annual Contract Quantity" or "ACQ" means for each Contract Year during the Delivery Period the quantity of Gas equal to the sum of the Daily Contract Quantities determined using the following formula:</p> $ACQ = \sum_{i=1}^n DCQ_{(i)}$ <p>Where:</p> <ul style="list-style-type: none"> <li>ACQ is the Annual Contract Quantity</li> <li>DCQ<sub>(i)</sub> is the Daily Contract Quantity for Day "i" in such Contract Year,</li> <li>i is each Day "i" in such Contract Year, and</li> <li>n is the number of Days in such Contract Year.</li> </ul> <p>"Daily Contract Quantity" or "DCQ" means for each Day during the Delivery Period a quantity of Gas equal to [____ (____)] [insert unit of energy amount].</p> <p>"Daily Actual Quantity" or "DAQ" means for each Day during the Delivery Period the total quantity of Gas made available and taken under this Agreement.</p> <p>"Maximum Daily Contract Quantity" or "MaxDCQ" means for each Day during the Delivery Period a quantity of Gas equal to [____] percent (____%) of the applicable DCQ.</p> <p>"Delay Liquidated Damages" means liquidated damages payable by Seller to Buyer in the event that the Gas Pipeline Facilities are not completed and operational by the Guaranteed Supply Date.</p> <p>"Delivery Point" means the Plant's gas receiving infrastructure located at the Site.</p> <p>"Gas Pipeline Facilities" means the approximately [ ] km natural gas pipeline and associated facilities (including metering) from the Seller's offshore gas extraction facilities to the Delivery Point, to be built owned and operated by Seller.</p> <p>"Guaranteed Supply Date" means [24] months from the signature date of this Agreement.</p> <p>"Payment Security" means an irrevocable standby letter of credit in the amount of US\$[insert amount] from Buyer to Seller to ensure timely payment by Buyer for</p>

Article	Provisions
	<p>the supply of natural gas under this Agreement and which shall be issued by an international bank with an investment grade rating in form and substance reasonably acceptable to Seller.</p> <p>"Performance Security" an irrevocable standby letter of credit in the amount of US\$[insert amount] from Seller to Buyer to guarantee Seller's obligations to pay Delay Liquidated Damages or Supply Liquidated Damages, and which shall be issued by an international bank with an investment grade rating in form and substance reasonably acceptable to Buyer.</p> <p>"Plant" means a [insert quantity] MW power plant to be located on Buyer's property in [site name], [province, country].</p> <p>"Supply Liquidated Damages" means liquidated damages payable by Seller to Buyer in the event of Seller's failure to deliver natural gas in accordance with the quantity and quality set forth in this Agreement.</p>
<b>Seller's Primary Obligations</b>	<ul style="list-style-type: none"> <li>• Finance, design, procure, construct, install, test, commission, operate and maintain the Gas Pipeline in accordance with prudent operating practice and compliant with the Gas Pipeline specifications to be included as an Annex to this Agreement.</li> <li>• Supply natural gas to the Buyer at the Delivery Point in accordance with the quantities and quality set forth in the Agreement.</li> <li>• Provide and maintain the validity of the Performance Security in accordance with the terms and conditions set forth in the Agreement.</li> </ul>
<b>Buyer's Primary Obligations</b>	<ul style="list-style-type: none"> <li>• Finance, design, procure, construct, install, test, commission, operate and maintain the Plant in accordance with prudent operating practice and compliant with the Plant specifications to be included as an Annex to this Agreement.</li> <li>• Purchase and take delivery of the natural gas at the Delivery Point in accordance with the quantities and quality set forth in the Agreement.</li> <li>• Provide and maintain the validity of the Payment Security in accordance with the terms and conditions set forth in the Agreement.</li> </ul>
<b>Condition Precedent to Effectiveness</b>	Buyer has achieved financial close with respect to any debt financing required to move forward with the construction of the Plant.
<b>Term</b>	<p>The GSA shall have a term of 25 years starting from the Commercial Operation Date of the Plant, provided, however, that the Agreement may be terminated earlier pursuant to the "Termination" clause.</p> <p>The GSA may be extended by operation of the extension provisions of the clauses on "Force Majeure", "Guaranteed Supply Date", and ["Supply Obligations"], or by mutual agreement of the Parties.</p>
<b>Quantity/Nominations</b>	<p>Subject to the maximum daily quantity ("MDQ") and maximum annual quantity ("MAQ"), Seller shall provide, on a firm basis and in accordance with the quality requirements set forth herein, all natural gas nominated by Buyer in accordance with this Agreement. In addition, Seller shall provide gas on an "as needed" basis to Buyer and as requested by Buyer during testing and commissioning of the Plant.</p> <p>No later than five (5) business days before the first (1st) day of each contract month after the Initial Supply Date, Buyer shall notify the Seller of the volume of</p>

Article	Provisions
	<p>natural gas Buyer nominates and requires that the Seller make available for each day of such contract month.</p> <p>Buyer shall have the right to modify any nomination so long as such modification is communicated to Seller at least 24 hours prior notice to delivery.</p> <p>Buyer may request modifications to any nomination with less than 24 hours prior notification in exceptional circumstances and Seller shall exercise its best efforts to accommodate such modifications.</p>
<b>Performance by Seller</b>	<p>In the event Seller fails to make available for delivery properly nominated volumes of natural gas as outlined above for any reason other than Force Majeure or Buyer's failure to accept delivery of natural gas, then Supplier shall be liable for Supply Liquidated Damages.</p>
<b>Delivery Point</b>	<p>The delivery point ("Delivery Point") for natural gas sold hereunder will be at the inlet flange of Buyer's receiving facilities located downstream of the proposed metering station at or on the Plant premises. Title and risk of loss will pass at the Delivery Point.</p>
<b>Price</b>	<p>Alternative #1 (Fixed Prices subject to escalation): The price of natural gas delivered by Seller to Buyer under this Agreement shall be \$[xxx]/MMBtu (the "Contract Price") with [xx]% indexed to the US consumer price index. In the event Buyer does not purchase 90% of the monthly nomination quantity in any given contract month, Buyer shall pay Seller [\$[xxx]/MMBtu * (90% - the percentage of the monthly nomination quantity purchased for such month)]. During the commissioning and testing of the Plant prior to commercial operations, the price for natural gas sold shall be \$[xxx]/MMBtu.</p> <p>Alternative #2 (Indexed Pricing): The price of natural gas delivered by Seller to Buyer under this Agreement shall be the sum of (x) a fixed component equal to US\$[xx]/MMBtu (of which [xx]% is fixed and [xx]% is indexed to the US consumer price index) and (y) a variable component equal to [110]% of the final settlement price for the New York Mercantile Exchange's Henry Hub natural gas futures contract for the month in which the natural gas was delivered.</p>
<b>Take or Pay Quantity</b>	<p>In each Contract Year Buyer shall be obligated to take and pay for, or to pay for if not taken, a quantity of natural gas at least equal to the Take or Pay Quantity. If, in any Contract Year, there is a "Buyer's Annual Deficiency Quantity", then Buyer shall pay the "Seller Buyer's Deficiency Payment" determined using the following formula:</p> $BDP = (BADQ - CFCQ) \times TOPP$ <p>Where:</p> <p>BDP is Buyer's Deficiency Payment for such Contract Year,</p> <p>BADQ is the positive difference (if any) between the Take or Pay Quantity and the actual quantity of natural gas purchased by Buyer for such Contract Year,</p> <p>CFCQ is the Carry Forward Credit Quantity, if any, for such Contract Year,</p> <p>TOPP is the average contract price for natural gas for such Contract Year.</p>

Article	Provisions
<b>Make-up and Carry Forward</b>	<p><u>Make-Up Right</u></p> <p>For any Contract Year in which the minimum take or pay quantity is greater than the quantity actually taken during such year, the deficiency shall be recorded and aggregated with any such deficiencies from previous years (collectively, the "Make-up Credits"). In subsequent Contract Years where Buyer has taken delivery of at least the Annual Contract Quantity attributable for such year, the Make-up Credits shall be available for use by Buyer as payment for any remaining volumes of gas taken in such Contract Year. Make-up credits shall expire after a period of [5] years.</p> <p>If at the end of the term of this Agreement, Buyer still has available Make-up Credits, then this Agreement shall be extended for a period up to [____ (____)] Months to enable Buyer to utilize such Make-up Credits.</p> <p><u>Carry Forward Right</u></p> <p>In the event that, for any Contract Year, Buyer takes more than the Annual Contract Quantity (excluding any amounts for which Make-up Credits are utilized), such excess quantity shall be carried forward as a credit to offset Buyer's take or pay deficiency in subsequent Contract Years; <i>provided that</i> the amount of the credit so applied shall not exceed [____] percent (____%) of the Annual Contract Quantity for the next Contract Year.</p>
<b>Taxes</b>	<p>All ad valorem, excise, reverence, production and other taxes assessed at or upstream of the Delivery Point will be borne by Seller. All such taxes assessed downstream of the Delivery Point will be borne by Buyer.</p>
<b>Invoicing and Payment</b>	<p>Seller shall send Buyer an invoice no later than the fifth (5<sup>th</sup>) day of each contract month for the natural gas purchased for the preceding contract month. Buyer shall submit the payment for the undisputed amount of each invoice within fifteen days of the end of the month applicable to such invoice.</p> <p>Payment of invoices must be made in US\$ by the stipulated time by wire transfer of immediately available funds. Overdue payments will accrue default interest at a rate per annum of 2% over LIBOR on and from the day payment was due.</p>
<b>Fuel Quality and Buyer's right to reject fuel</b>	<p>The quality of gas delivered under the GSA at the Delivery Point will meet or exceed the quality specifications (including minimum and maximum delivery pressure) described in Exhibit [x] attached hereto. If within 30 days of Buyer's notification to Seller that natural gas fails to meet such quality specifications Seller is unable to cure the non-conforming natural gas, Buyer may terminate the GSA.</p>
<b>Liabilities and Indemnification</b>	<p>Alternative #1: Seller is liable to Buyer and Buyer is liable to Seller, for any loss which has been suffered as a result of the breach by the Party liable of any one or more of its obligations under this Agreement, to the extent that the Party liable should reasonably have foreseen the loss. The Parties additionally provide certain indemnities in connection with various specific losses [insert list of these specific indemnities.</p>

Article	Provisions
	Alternative #2: Customary for natural gas supply agreements of this kind for power projects financed on a non-recourse basis.
<b>Limitation of Liability</b>	Neither Party shall be liable to the other Party under this GSA as a result of any act or omission in the course of or in connection with the performance of this Agreement, for or in respect of any indirect, incidental, consequential or exemplary losses or any loss of income or profits; or except as expressly provided in this GSA, any failure of performance or delay in performance to the extent relieved by the application of force majeure in accordance with this Agreement; [or any losses arising from any claim, demand or action made or brought against the other party by a third party].
<b>Default, Suspension, and Termination</b>	<p>This Agreement shall terminate if:</p> <ul style="list-style-type: none"> <li>• The Effective Date does not occur by [ ].</li> <li>• Buyer fails to take delivery of any natural gas within [xx] days of the Effective date unless such failure is attributable to Seller or a Force Majeure Event which shall automatically extend the allotted period on a day for day basis.</li> <li>• Buyer fails to take delivery of at least 50% of the Annual Contracted Quantity for 2 consecutive contract years.</li> <li>• Buyer or Seller suffers a Prolonged Force Majeure Event and the other Party exercises its right to terminate for such circumstance in accordance with this Agreement.</li> <li>• An Event of Default occurs, is continuing and has not been cured within the applicable time period set forth in this Agreement, and the non-defaulting Party has provided notice of termination in accordance with the procedure set forth herein.</li> <li>• The expiration of the Term.</li> </ul>
<b>Seller Events of Default</b>	<ul style="list-style-type: none"> <li>• Assignment of the rights or obligations under the GSA that is not expressly permitted pursuant to the Assignment clause of this Agreement.</li> <li>• Seller fails to make available at least 50% of the Annual Contract Amount for two (2) consecutive contract years.</li> <li>• Seller fails to comply with its obligations with respect to the Performance Security</li> <li>• Seller suffers a specified bankruptcy event.</li> <li>• Seller is in material breach of any of its other obligations under this Agreement and such breach is not remedied within one hundred and eighty (180) days of Seller providing written notice thereof.</li> </ul>
<b>Buyer Events of Default</b>	<ul style="list-style-type: none"> <li>• Assignment of the rights or obligations under the GSA that is not expressly permitted pursuant to the Assignment clause of this Agreement.</li> <li>• Buyer fails to comply with its obligations with respect to the Payment Security.</li> <li>• Buyer fails to make timely payment of any amount due under this Agreement (except for amounts subject to good faith dispute) and does not remedy such failure within thirty (30) days of such due date.</li> <li>• Buyer suffers a specified bankruptcy event.</li> </ul>

Article	Provisions
	<ul style="list-style-type: none"> <li>Buyer is in material breach of any of its other obligations under this Agreement and such breach is not remedied within one hundred and eighty (180) days of Seller providing written notice thereof.</li> </ul>
<b>Dispute Resolution</b>	<p>Disputes regarding measurements or other disputes as agreed by the Parties will be determined by expert determination. All other disputes will be resolved through arbitration conducted in accordance with the American Arbitration Association rules and will take place in the Co-operative Republic of Guyana.</p>
<b>Governing Law</b>	<p>If GPL is the Plant owner: The laws of the Co-operative Republic of Guyana.</p> <p>If a foreign sponsor is the Plant owner: The laws of the State of New York, USA.</p>
<b>Force Majeure</b>	<p>Neither party shall be liable to the other for delay or failure attributable to Force Majeure subject to the affected Party exercising commercially reasonable efforts to overcome or mitigate the effects of such events.</p> <p>For purposes of this Agreement, "Force Majeure" shall mean a cause or event (i) that is beyond the reasonable control of the affected Party and was not due to the fault or negligence of the affected Party and that prevents such Party's performance of its obligations under or pursuant to this Agreement, and (ii) which the affected Party is unable to prevent, overcome or remedy by the exercise of diligence and reasonable care, or avoid by the exercise of reasonable foresight and mitigation.</p> <p>"Force Majeure" shall include the following events and circumstances, but only to the extent that each satisfies the above requirements:</p> <ul style="list-style-type: none"> <li>floods, hurricanes, tornadoes, typhoons, cyclones, earthquakes and other natural calamities;</li> <li>fires or explosions that could not have been prevented by acting in accordance with industry standards or prudent operating practice, as applicable;</li> <li>war (declared or undeclared), riots, insurrection, rebellion, civil disturbance, acts of the public enemy, acts of terrorism and sabotage, blockades, embargoes or sanctions;</li> <li>strikes which are widespread within the Co-operative Republic of Guyana, regional and industry-wide labor disputes unless affecting only or caused by Buyer, Seller or their contractors (or their subcontractors of any tier) or their employees; and</li> <li>any change in law.</li> </ul> <p>Force Majeure shall expressly not include the following conditions, except and to the extent that they result from a Force Majeure:</p> <ul style="list-style-type: none"> <li>the absence of sufficient financial means to perform obligations or the failure to make payments in accordance with this Agreement;</li> <li>weather conditions that could reasonably be expected to occur by an experienced contractor or electric generator in the Co-operative Republic of Guyana other than extreme or unusually severe weather conditions that constitute a Force Majeure event in accordance with clause above;</li> </ul>

Article	Provisions
	<ul style="list-style-type: none"> <li>• shortages, unavailability, late delivery, or changes with respect to materials, spare parts, supplies, consumables or components of equipment;</li> <li>• price fluctuations with respect to materials, spare parts, supplies, consumables or components of equipment;</li> <li>• late delivery of materials, supplies or components of equipment;</li> <li>• economic hardship;</li> <li>• shortages of manpower;</li> <li>• the delay, default or failure to perform by a contractor or subcontractor;</li> <li>• machinery or equipment breakdown; and</li> <li>• customs procedures</li> </ul> <p>No event, whether or not it constitutes Force Majeure will excuse a Party from an obligation to make any payment when due and payable under this Agreement.</p>
<b>Insurance Requirements</b>	Customary insurance provisions for transactions of this kind, to be added as Exhibit 4.
<b>Assignment and Financing</b>	The GSA will not be assignable to a non-affiliated company without the consent of the other Party thereto, not to be unreasonably withheld, provided, however, that Buyer may assign, pledge or otherwise burden its interest in the GSA in connection with a financing or purchase of the Plant. In connection with the financing of the Plant, Seller will execute or otherwise provide GSA amendments, consents, opinions, certificates and other documentations which are reasonably requested by the lenders consistent with non-recourse financing customary for Plants of this kind with due consideration to the Plant location.
<b>Conditions Precedent</b>	The effectiveness of the GSA will be subject to Buyer obtaining financing for the Plant.
<b>Non-Recourse Obligations</b>	Notwithstanding any other provision of the GSA to the contrary, the obligations for Buyer thereunder are intended to be recourse only to the assets of Buyer, and neither the partners thereof nor any shareholders, officers, or agent of any partners or any affiliate thereof shall have any personal responsibility or liability for any breach in performance or observance of the covenants, representatives or obligations under the GSA.
<b>Miscellaneous</b>	The Contract shall contain such other clauses and provisions as are customary in the international power generation industry for transactions of a similar kind and nature where the power plant is financed on a non-recourse basis including representations and warranties, compliance with law, confidentiality,

**List of Exhibits (to be inserted during GSA negotiations)**

Exhibit 1 - Definitions

Exhibit 2 – Fuel Specification, Testing, and Measurement

Exhibit 3 – Forms of Daily/Monthly Nominations

Exhibit 4 – Insurance

## Appendix D: GSA risk mitigation

Risk	Description / Consequences	Potential Sources of Mitigation	Allocation	Document
<b>PRE-CONSTRUCTION RISKS</b>				
1 Deficient Project Definition	<p>Insufficient or sub-optimal Project definition during concept and feasibility phase brings the risk of:</p> <ul style="list-style-type: none"> <li>Lack of competitive bidders (i.e. failure of tender process)</li> <li>Project delay or failure (sunk development costs)</li> <li>Excessive capital costs (higher tariffs)</li> <li>Higher funding costs (higher tariffs)</li> <li>Mismatch between project design and consumption needs</li> <li>Lack of credibility to attract future investment in the sector</li> </ul>	<ul style="list-style-type: none"> <li>Conduct a technical and financial feasibility, including a market analysis to establish Project definition within the context of what the market needs and how the market is expected to develop and expand</li> <li>Early stage identification of key risks, available mitigation tools, and bankability requirements</li> <li>A comprehensive RFP document tailored to the results of the feasibility analysis, Project risks, and bankability requirements</li> <li>Work closely with experienced consultant</li> </ul>	Initially GoG and subsequently Project Company	RFP
2 Gaps in Regulatory Framework or Political Support	<p>Significant gaps in the regulatory framework could result in:</p> <ul style="list-style-type: none"> <li>Lack of competitive bidders (i.e. failure of tender process)</li> <li>Higher funding costs</li> <li>Inability to secure project financing</li> </ul>	<ul style="list-style-type: none"> <li>Early-stage identification and resolution of any regulatory gaps that could hinder investment in the sector</li> <li>Gain sustainable consensus and commitment from relevant Government stakeholders (e.g. MPI, GEA, PUC and MOP) regarding the Project rationale and structure</li> <li>Properly tailor the Project's technical, commercial, and contractual structure to the</li> </ul>	GoG regulatory entities Project Company	GSI



Risk	Description / Consequences	Potential Sources of Mitigation	Allocation	Document
	<ul style="list-style-type: none"> <li>Lack of credibility to attract future investment in the sector</li> </ul>	<ul style="list-style-type: none"> <li>regulatory framework to be in place during implementation</li> <li>DFI participation (debt, partial risk guarantees)</li> <li>Government-support instrument ("GSI")</li> <li>Work closely with a consultant that has relevant policy / regulatory experience and has brought power projects successfully through financial closing</li> </ul>		
3	<p>Bidder request to increase tariff post-award</p> <p>A bidder may attempt to obtain a higher tariff after being selected as preferred bidder, potentially leading to significant Project delay or failure and additional transaction costs.</p>	<ul style="list-style-type: none"> <li>Prequalify bidders with proven track record of financing IPPs or PPs in developing countries</li> <li>Require an appropriate level of proposal security which can be easily drawn down in case of failure to comply</li> <li>Require preferred bidder (and second ranked bidder) to hold prices valid for length of negotiations and include additional extension if beyond</li> <li>Require bidders to provide a financing plan and "commitment letters" from lenders</li> </ul>	Project Company	RFP
4	<p>Delay securing land for the power plant and water supply infrastructure</p> <p>Failure to secure all required land and land use can lead to lack of competitive bids, significant delays in financing and implementation, or project cancellation.</p>	<ul style="list-style-type: none"> <li>Begin securing land and rights of way for power plant and water supply infrastructure as soon as feasibility study is complete</li> </ul>	GoG	LLA PPA
5	<p>GoG failure to provide timely Project permits and approvals (or lapse of such approvals)</p> <p>Given that there is no precedent for development of a large gas-fired power plant in Guyana, there will be risk associated with delays in securing Government approvals required for construction and operation of the Project which could lead to lack of competitive bids, additional costs, Project delay, or cancellation.</p>	<ul style="list-style-type: none"> <li>Early stage identification of all Project approvals required and any need for regulatory adjustment</li> <li>Effective planning and coordination between Project Company and GPL</li> <li>Schedules and responsibilities clearly understood and mutually agreed by all parties</li> <li>Deemed commissioning in cases where target COD is not met due to delay in a Government Approval not attributable to Project Company</li> </ul>	GoG GPL	RFP PPA GSI

Risk	Description / Consequences	Potential Sources of Mitigation	Allocation	Document	
6	Delay or failure reaching Financial Close	After preferred bidder is selected, certain conditions will need to be met for Project contracts to become fully effective and for lender sign-off on financial close. Such conditions may be subject to delay and/or failure due to fault of the bidder, other stakeholders, or force majeure leading to (i) Project delay or failure, (ii) loss of sunk development costs, and (iii) reduced credibility to attract future investment in the sector.	<ul style="list-style-type: none"> <li>GSI with provision supporting Project Company in obtaining and maintaining necessary Project approvals and for termination and transfer at pre-agreed price upon GoG default</li> <li>Develop bankable project structure</li> <li>Pregualify financially viable and experienced sponsors</li> <li>Transparent and efficient regulations related to land use and permitting</li> <li>GoG to provide the necessary conditions to facilitate financing under Guyana's present investment environment</li> <li>GoG/GPL to support approval process for Project approvals (e.g. permits, licenses)</li> <li>Monitor Project Company's development progress supported by monthly progress reports</li> <li>Proposal security to be drawn for failure to achieve financial close by long-stop date when attributable to preferred bidder</li> <li>Maintain validity of proposal from second-ranked bidder</li> </ul>	Project Company GoG	RFP GSI
<b>CONSTRUCTION PERIOD RISKS (excluding force majeure)</b>					
7	Construction delays within Project Company's control	Project Company failure to achieve commercial operation date by the target date	<ul style="list-style-type: none"> <li>Establish realistic COD target date</li> <li>Ensure that Project Company engages an EPC Contractor with the experience and capabilities to successfully build the Project in Guyana</li> <li>Liquidated damages payable by Project company backed by sufficient construction security (e.g. standby letter of credit)</li> <li>EPC Contractor to provide bonding and liquidated damages in favor of Project Company</li> <li>Monitor all stages of EPC activity supported by monthly progress reports</li> </ul>	Project Company EPC Insurers	PPA EPC Insurance

Risk	Description / Consequences	Potential Sources of Mitigation	Allocation	Document
8	<p>Delay in gas connection</p> <p>Gas supplier is unable to complete gas connection by the time required for Project to achieve COD by target COD date leading to Project delay and additional cost.</p>	<ul style="list-style-type: none"> <li>• Builders all-risk and other customary insurance policies</li> <li>• Termination right if COD is not reached by long-stop date</li> <li>• Firm obligation of gas supplier to complete connection by a date certain.</li> <li>• Transparent and efficient regulations related gas pipeline permitting and operation</li> <li>• GoG support of approval process for gas connection approvals (e.g. permits, licenses)</li> <li>• Coordinate gas pipeline and Facility construction schedules</li> <li>• Builders all-risk and other customary insurance policies</li> <li>• Deemed COD when delay is not attributable to Project Company</li> <li>• Arrange for flexible back up fuel (HFO) arrangements and include an appropriate level of fuel storage in the power plant scope</li> </ul>	<p>GoG</p> <p>Gas supplier</p> <p>GPL</p> <p>Insurers</p>	<p>PPA</p> <p>FSA</p> <p>Insurance</p>
9	<p>Delay in 69-KV/230-KV transmission line; grid system unavailability; or transmission congestion</p> <p>Failure by Project Company and / or GPL to complete transmission line by the time required by the Project to achieve COD by the target COD date leading to Project delay and additional cost.</p>	<ul style="list-style-type: none"> <li>• Coordinate transmission line and Facility construction schedules</li> <li>• Arrange to have land and permits secured prior to financial close or early in the Project construction schedule</li> <li>• Consider multiple routing options to reduce risk of delay associated with land access and permitting</li> <li>• Closely supervise transmission line contracting, construction and commissioning</li> <li>• Require delay liquidated damages payable by transmission line sponsor and EPC contractor</li> <li>• Deemed COD if Project is prevented from achieving COD by target COD date due to unavailability of the line (Project received capacity payments)</li> </ul>	<p>GoG</p> <p>GPL</p> <p>Project Company</p>	<p>PPA</p> <p>T-line EPC</p> <p>GSI</p>

Risk	Description / Consequences	Potential Sources of Mitigation	Allocation	Document	
10	Gas treatment plant at landing point not designed to match power plant operational requirements	<ul style="list-style-type: none"> <li>OEM's specifications included in gas treatment plant and gas receiving station</li> <li>Gas receiving station including sufficient redundancy</li> </ul>	Gas Supplier EPC Contractor	FSA EPC	
11	Construction cost overruns within Project Company's control	<ul style="list-style-type: none"> <li>Preferred bidder to have sufficient financial qualifications</li> <li>Experienced EPC Contractors</li> <li>Establish realistic schedule</li> <li>Turnkey, date certain EPC Contract</li> <li>Monitor all stages of EPC activity</li> <li>EPC contractor responsible for delay liquidated damages backed by bankable security (e.g. standby letter of credit)</li> <li>Adequate construction period insurance program</li> </ul>	Project Company EPC Contractor Insurer	RFP EPC Insurance	
12	Project Company abandons Project	<ul style="list-style-type: none"> <li>Risk that the Project Company abandons construction for reasons such as financial distress or the inability or unwillingness to complete leading to significant delay to find replacement and transaction costs</li> </ul>	<ul style="list-style-type: none"> <li>Selection of qualified sponsor</li> <li>Project to be well defined and structured</li> <li>Sufficient amount of performance security to de-incentivize abandonment and cover a portion of resulting transaction costs for sponsor replacement</li> <li>Protective termination rights under the PPA</li> </ul>	Project Company	<ul style="list-style-type: none"> <li>RFP</li> <li>PPA</li> </ul>
<b>OPERATION PERIOD RISKS (excluding force majeure)</b>					
13	Operating cost overruns for events within Project Company's control	<ul style="list-style-type: none"> <li>Failure of Project Company to maintain operational budget brings risk of: <ul style="list-style-type: none"> <li>Financial distress on Project Company and/or EPC contractor</li> </ul> </li> </ul>	<ul style="list-style-type: none"> <li>Ensure that bidders have sufficient operation experience or have contracted a qualified third-party operator</li> <li>PPA price and / or liquidated damage structure designed to reflect performance deficiencies</li> </ul>	Project Company O&M Contractor Insurers	RFP Insurance

Risk	Description / Consequences	Potential Sources of Mitigation	Allocation	Document
14 Gas supply interruption or supply below required levels (Commercial)	Gas supplier's failure to supply gas leading will lead to lower plant availability, higher fuel costs, or replacement power costs	<ul style="list-style-type: none"> <li>Termination rights for extended periods of materially deficient operational performance</li> <li>Operational period insurance policy</li> <li>Confirm gas supplier has enough gas reserves to meet contracted supplies, and planned additional uses</li> <li>Firm supply obligation under the FSA with liquidated damages for failure to supply and supported by performance security (e.g. standby letter of credit)</li> <li>Arrange for flexible back up fuel (HFO) arrangements and include an appropriate level of fuel storage in the power plant scope</li> <li>Insurance for coverable events</li> </ul>	Gas supplier GPL Insurers	FSA Back-up fuel supply and transport contract/s Insurance
15 Grid system unavailability	Unavailability to evacuate energy into the grid will result in underutilization of the plant, less efficient operation and higher system costs to be absorbed by GPL and end consumers.	<ul style="list-style-type: none"> <li>Effective grid planning and operation</li> <li>GPL to pay PPA capacity payments during periods of grid system unavailability unless attributable to fault of Project Company</li> <li>GPL or GoG to compensate gas supplier for any failure to meet take-or-pay supply volumes</li> <li>Termination and transfer rights under PPA for prolonged periods of system unavailability (including a Project Company "put" to GoG at a price that includes repayment of Project debt and a reasonable return on investment to equity holders)</li> </ul>	GPL GoG	PPA FSA GSI
16 Gas quality at delivery point	Failure to meet fuel specifications brings risk of lower plant availability, higher fuel costs, and/or replacement power costs.	<ul style="list-style-type: none"> <li>OEM's fuel specifications included as a contractual requirement</li> <li>Ability of Project Company to reject non-compliant gas</li> <li>Liquidated damages payable by gas supplier for failure to deliver compliant gas</li> </ul>	Gas Supplier	FSA
17 GPL failure to pay capacity, energy or any other	Prospective bidders and lenders will be attentive to GPL credit risk since any delay or failure to make capacity and	<ul style="list-style-type: none"> <li>Refinance GPL's payables to existing IPPs</li> <li>Adjust retail tariff to make it cost-reflective</li> <li>Implement program to reduce GPL receivables</li> </ul>	GoG GPL DHs	PPA GSI

Risk	Description / Consequences	Potential Sources of Mitigation	Allocation	Document
	payments on time	energy payments will directly impact Project Company equity/returns, debt service, and bankruptcy risk.	<ul style="list-style-type: none"> <li>DFI participation (e.g. debt, partial risk guarantees)</li> <li>PPA payment security</li> <li>Termination and transfer rights under PPA (including a Project Company "put" to GoG at a price that includes repayment of Project debt and a reasonable return on investment to equity holders)</li> </ul>	Project Company  Financing Package
18	Interest rate fluctuations	Interest rate fluctuation can reduce Project Company equity/returns and create financial distress	<ul style="list-style-type: none"> <li>Only prequalify bidders with successful track record of financing IPPs in developing countries</li> <li>Require bidders to provide interest rate swap information as part of its proposals</li> </ul>	Project Company  RFP
19	Inflation; adverse changes in exchange rates	Inflation and currency risk can lead to financial distress of the Project Company and GPL	<ul style="list-style-type: none"> <li>Inflation-sensitive cost components to be subject to escalation in the PPA payment formulas.</li> <li>[PPA tariff in US\$]</li> <li>Include appropriate adjustment mechanisms in sector tariff setting to reflect the operation of the PPA tariff mechanism</li> </ul>	GPL  RFP PPA
20	Currency conversion	Unavailability of conversion from local to foreign currency must be mitigated prior to financial close to ensure ability to pay debt service and achieve adequate equity returns.	<ul style="list-style-type: none"> <li>GoG (or Bank of Guyana) guarantee of foreign currency convertibility and availability</li> <li>Guarantee and insurance mechanisms available from multilateral and bilateral financing institutions (e.g. MIGA, OPIC)</li> <li>Termination and transfer rights under PPA and/or GSI (including a Project Company "put" to GoG at a price that includes repayment of Project debt and a reasonable return on investment to equity holders)</li> </ul>	GoG (BoG) Insurer  GSI PPA
21	Expropriation	Government taking of the Project or squeezing the Project by means of taxation, regulation, access or change of law leading to loss of	<ul style="list-style-type: none"> <li>GSI</li> <li>DFI participation</li> <li>Political risk insurance from multilateral and/or bilateral entities</li> </ul>	GoG DFI Insurer  GSI PPA Insurance

Risk	Description / Consequences	Potential Sources of Mitigation	Allocation	Document
	investment value by Project investors and debtholders	<ul style="list-style-type: none"> <li>Termination and transfer rights under PPA and/or GSI (including a Project Company "put" to GoG at a price that includes repayment of Project debt and a reasonable return on investment to equity holders)</li> </ul>		
22 Plant operational performance	Failure to operate at the expected capacity, efficiency, environmental, and availability levels leading to higher fuel costs, replacement and energy available to consumers, less reliability and increased plant emissions.	<ul style="list-style-type: none"> <li>EPC Contract to include performance guarantees and provisions for liquidated damages</li> <li>Well qualified EPC Contractor and equipment suppliers (proven technology)</li> <li>O&amp;M Contract (unless self-operation applies) to include performance guarantees and provisions for liquidated damages</li> <li>Well qualified O&amp;M contractor and equipment suppliers</li> <li>PPA tariff and liquidated damage provisions to properly reflect plant performance deficiencies, including Project Company payment for excess fuel usage</li> <li>Minimum threshold performance required to achieve COD (robust plant testing regime)</li> <li>Appropriate level of construction performance security</li> <li>Well defined technical specifications in PPA</li> <li>Customary plant insurance policies for both construction and operation periods</li> </ul>	Project Company O&M Contractor EPC Contractor Insurer	RFP PPA EPC O&M Contract Insurance
23 Lower than expected electricity demand	If the plant is not needed to run at baseload (or close to baseload), the ultimate consumers will need to continue paying for the Project (and a minimum gas supply take) even though it may be underutilized. This situation could lead to consumer pushback on tariff	<ul style="list-style-type: none"> <li>Perform a market study to provide a baseline for determining Project capacity, fuel, technology and configuration</li> <li>Continuously adjust expansion plan to avoid oversupply</li> <li>Ensure that regulatory framework is geared towards preventing oversupply</li> <li>Negotiate gas supply take that is as flexible as practicable and identify and implement mitigation measures to re-allocate unused gas</li> </ul>	GoG / GPL	PPA GSI FSA

Risk	Description / Consequences	Potential Sources of Mitigation	Allocation	Document
	levels and financial distress at GPL.			
<b>FORCE MAJEURE RISKS</b>				
Force Majeure (other than Local Political Force Majeure)	Force Majeure events can negatively impact Project construction schedule, number of outages, plant operational performance, capital cost, operating costs, and even lead to total loss.	<ul style="list-style-type: none"> <li>Requirement of robust insurance policies for the EPC contractor and Project Company (including builders all risk, advanced loss of profit, and business interruption).</li> <li>Contract force majeure provisions that are tailored to this Project and do not have any unintended gaps between EPC, FSA, and PPA.</li> <li>Day for day schedule relief and contract extension in the EPC, FSA, and PPA.</li> <li>Mutual rights to terminate in case of prolonged force majeure.</li> <li>Termination and transfer rights under PPA and/or GSI for prolonged force majeure (transfer price to cover repayment of Project debt and some level of return on investment to equity holders)</li> </ul>	<p>Insurers GPL Project Company</p>	<ul style="list-style-type: none"> <li>RFP</li> <li>PPA</li> <li>GSI</li> </ul>
24 Local Political Force Majeure (e.g. civil strike, national labor strike)	Local Political Force Majeure events can negatively impact Project construction schedule, number of outages, plant operational performance, capital cost, operating costs, and even lead to total loss.	<ul style="list-style-type: none"> <li>Day for day schedule relief and contract extension in the EPC, FSA, and PPA.</li> <li>Project Company right to terminate in case of prolonged Local Political Force Majeure.</li> <li>GoG or GPL to continue paying PPA capacity charges during a Local Political Force Majeure Event</li> <li>Project Company right to transfer Project to GSI or GoG at pre-agreed transfer price in case of prolonged Local Political Force Majeure (transfer price to cover repayment of Project debt and a reasonable return on investment to equity holders)</li> <li>GoG pays for restoration costs due to Local Political Force Majeure resulting in damage to the plant</li> <li>Political risk insurance</li> </ul>	<p>GoG GPL Insurers</p>	<p>GSI PPA Insurance</p>



Risk	Description / Consequences	Potential Sources of Mitigation	Allocation	Document
<p>25 Change-in-Low ("CIL") requiring changes to Facility or adversely impacts Project economics</p>	<p>CILs which delay construction, suspend or alter normal plant operations or increase Project cost can lead to Project delays, lower equity returns, and challenges for meeting debt service obligations.</p>	<ul style="list-style-type: none"> <li>GoG to carefully review requirements imposed on Project; anticipate changes and include in Project Agreements</li> <li>CIL provisions providing day for day schedule relief, contract extensions, and cost relief (subject to minimum thresholds) in the EPC, FSA, and PPA.</li> <li>GoG or GPL to continue paying PPA capacity charges during a CIL during the operational period and deemed commissioning if a CIL is the cause for failure to achieve COD by the target COD date</li> </ul>	<p>GoG GPL</p>	<ul style="list-style-type: none"> <li>GSI</li> <li>PPA</li> </ul>

## Appendix E: Generation Outputs

All units in GWh

Model Year	2023	2024	2025	2026	2027	2028	2029	2030	2031	2032	2033	2034	2035	2036	2037	2038	2039	2040	2041	2042	2043	2044	2045	2046	2047	
<b>30 MMSCFD</b>																										
Generation from LM 2500 CC	880	1,127	1,329	1,421	1,036	1,090	1,095	1,099	1,103	1,111	1,115	1,122	1,127	1,138	1,148	1,159	1,168	1,178	1,188	1,197	1,206	1,215	1,224	1,233	1,242	
Generation from Wartsila	877	1,137	1,213	1,232	1,011	1,046	1,049	1,051	1,054	1,059	1,062	1,067	1,070	1,077	1,084	1,091	1,098	1,104	1,111	1,117	1,123	1,129	1,134	1,140	1,146	
<b>50 MMSCFD</b>																										
Generation from LM 2500 CC	727	990	1,187	1,402	1,629	1,810	1,822	1,834	1,846	1,858	1,890	1,903	1,917	1,929	1,942	1,955	1,967	1,979	1,992	2,004	2,016	2,028	2,040	2,052	2,064	
Generation from Wartsila	702	965	1,174	1,395	1,627	1,791	1,801	1,812	1,822	1,832	1,841	1,851	1,860	1,868	1,877	1,885	1,892	1,900	1,907	1,915	1,922	1,929	1,935	1,942	1,948	

## Appendix F: Cost Estimates

---

The details of the cost estimate performed using GPTO PEACE software are presented below. Civil cost estimates are based on a generic site considering the coastal characteristics of most of the Guyana coastal areas. Multipliers are used to adjust the generic cost estimate to the Guyana conditions.

### F.1 RICE 30 MMscfd

Project Cost Summary	Reference Cost	Estimated Cost	
I Specialized Equipment	73,175,100	80,492,612	USD
II Other Equipment	2,039,058	2,039,058	USD
III Civil	7,195,272	12,961,491	USD
IV Mechanical	10,222,362	7,540,735	USD
V Electrical Assembly & Wiring	3,765,866	2,807,528	USD
VI Buildings & Structures	5,936,096	17,771,137	USD
VII Engineering & Plant Startup	4,247,300	4,247,300	USD
Gasification Plant	0	0	USD
Desalination Plant	0	0	USD
CO2 Capture Plant	0	0	USD
Subtotal - Contractor's Internal Cost	106,581,054	127,859,860	USD
VIII Contractor's Soft & Miscellaneous Costs	27,839,855	24,156,012	USD
Contractor's Price	134,420,909	152,015,872	USD
IX Owner's Soft & Miscellaneous Costs	12,097,882	11,881,428	USD
Battery Storage System	0	0	USD
Total - Owner's Cost	146,518,791	163,897,300	USD
Net Plant Output	152.5	152.5	MW
Price per kW - Contractor's	881	997	USD per kW
Cost per kW - Owner's	961	1,075	USD per kW

NOTE: Following totals refer to power plant only.  
The gasification, desalination, and CO2 capture plants are not included.

Power Plant Totals (Reference Basis):	Reference Cost	Hours
Commodities	10,456,810	
Labor	11,477,990	261,033

Effective Labor Rates:	Cost per Hour
Civil Account	39.02
Mechanical Account	44.00
Electrical Account	45.00

Power Plant Buildings	% of Total Cost	Estimated Cost	Hours
Labor	50	2,968,048	
Material	50	2,968,048	
Labor Hours			72,896

	Item Cost	Unit Cost	Quantity	Ref. Cost	Est. Cost
<b>I Specialized Equipment (USD)</b>					
<b>1. Recip Engine Package</b>		6,431,000	9	73,175,100	80,492,612
Recip Engine Genset (including multi-unit discount)	5,840,000				
Inlet Filter/Silencer System (w/ elements)	included				
Evaporative Cooling System					
Inlet Fogging System					
Exhaust Stack/Silencer System					
Electrical/Control/Instrumentation Package	included				
Gas Fuel Package	included				
Liquid Fuel Package	181,800				
Fuel Heating Package					
Steam Injection Package					
Water Injection Package					
Starting Package	included				
Lube Oil Package w/ main, auxiliary & emergency pump	included				
Compressor Water Wash System					
High Voltage Generator					
OEM supplied technical oversight & services required for warranty	included				
User-defined shipping cost [7%]	408,850				
<b>2. Steam Turbine Package</b>				0	0
Turbine					
Generator					
Exhaust System					
Electrical/Control/Instrumentation Package					
Lube Oil Package w/ main, auxiliary & emergency pump					
High Voltage Generator					
OEM supplied technical oversight & services required for warranty					
User-defined shipping cost [8%]					
<b>3. Recip Engine Exhaust System</b>		816,000	9	7,344,000	8,078,400
Duct Burner & Burner Management System					
Exhaust Transition	included				
Bypass Stack					
Main Stack	128,800				
Instrumentation	included				
SCR & Aqueous Ammonia System	312,650				
CO catalytic reactor for CO reduction	173,700				
Deaerator					
Steam Vents & Water Drains					
Non-Return Valves					
Blowdown Recovery System					
Forced Circulation Pumps					
OEM supplied technical oversight & services required for warranty	included				
User-defined shipping cost [10%]	74,200				
<b>4. Water-cooled Condenser</b>				0	0
Vacuum Pump					
Steam Jet Air Ejector					
User-defined shipping cost [8%]					
<b>5. Air-cooled Condenser</b>				0	0
Tube Bundles					
Fans, Gears, and Motors					
Steam Duct & Condenser Piping					
Turbine Exhaust Transition					
Steam Jet Air Ejector					
Condensate Receiver Tank					
Support Structures					
User-defined shipping cost [8%]					
<b>6. Inlet Air Chilling / Heating System</b>				0	0
Main Chiller Unit					
Chilling / Heating Water Coil					
Chiller Cooling System					
Approximate shipping to typical US site					
<b>7. Fuel Gas Compressor</b>				0	0
Fin Fan Cooling System					
Approximate shipping to typical US site					
<b>8. Continuous Emissions Monitoring System</b>		1,540,000	1	1,540,000	1,694,000
Enclosures	included				
Electronics, Display Units, Printers & Sensors	included				
Approximate shipping to typical US site	included				
<b>9. Distributed Control System</b>				0	0
Enclosures					
Electronics, Display Units, Printers & Sensors					
Approximate shipping to typical US site					
<b>10. Transmission Voltage Equipment</b>		5,554,000	1	5,554,000	6,109,400
Transformers	4,886,000				
Circuit Breakers	404,100				
Miscellaneous Equipment	264,500				
Approximate shipping to typical US site	included				
<b>11. Generating Voltage Equipment</b>		858,100	1	858,100	943,910
Generator Buswork	581,400				
Circuit Breakers	235,900				
Current Limiting Reactors					
Miscellaneous Equipment	40,860				
Approximate shipping to typical US site	included				
<b>12. User-defined</b>				0	0

	Unit Cost	Quantity	Ref. Cost	Est. Cost
<b>II Other Equipment (USD)</b>			<b>2,039,058</b>	<b>2,039,058</b>
<b>1. Pumps</b>			<b>191,800</b>	<b>191,800</b>
Integral Feedwater Pump				
HP Feedwater Pump				
IP Feedwater Pump				
LP Feedwater Pump				
Condensate Forwarding Pump				
Condenser C.W. Pump				
Condenser Vacuum Pump				
Treated Water Pump				
Demin Water Pump				
Raw Water Pump 1				
Raw Water Pump 2				
Raw Water Pump 3				
GT Water Injection Pump				
GT Evap Cooler Water Pump				
Auxiliary Boiler Feedwater Pump				
Fuel Oil Unloading Pump	9,070	1	9,070	9,070
Fuel Oil Forwarding Pump	5,290	2	10,580	10,580
Aux Cooling Water Pump (closed loop)				
Diesel Fire Pump	70,500	1	70,500	70,500
Electric Fire Pump				
Jockey Fire Pump	4,450	1	4,450	4,450
Inlet Air Chiller/Heater Water Pump				
Recip Engine+Generator Lube Oil Coolant Pump	5,400	18	97,200	97,200
Generator Lube Oil Coolant Pump				
Generator Cooling Pump				
Chiller Coolant Pump				
Fuel Compressor Coolant Pump				
ST+Generator Lube Oil Coolant Pump				
ST Generator Cooling Pump				
Aux Cooling Water Pump (open loop)				
<b>2. Tanks</b>		<b>3</b>	<b>198,100</b>	<b>198,100</b>
Fuel Oil	134,450	1	134,450	134,450
Hydrous Ammonia	9,800	1	9,800	9,800
Demineralized Water				
Raw Water				
Neutralized Water				
Acid Storage				
Caustic Storage				
Waste Water				
Dedicated Fire Protection Water Storage	53,850	1	53,850	53,850
Chilled Water Storage				
Process Water Storage				
District Heating Water Storage				
<b>3. Cooling Tower</b>				
<b>4. Auxiliary Heat Exchangers</b>			<b>376,740</b>	<b>376,740</b>
Auxiliary Cooling Water Heat Exchanger				
Auxiliary Cooling Tower				
Recip Engine+Generator Lube Oil Fin Fan Cooler	20,930	18	376,740	376,740
Generator Lube Oil Fin Fan Cooler				
Generator Fin Fan Cooler				
Chiller Fin Fan Cooler				
Fuel Compressor Fin Fan Cooler				
ST+Generator Lube Oil Fin Fan Cooler				
ST Generator Fin Fan Cooler				
Miscellaneous Heat Exchangers				
<b>5. Feedwater Heater(s)</b>				<b>0</b>
<b>6. Auxiliary Boiler</b>				
<b>7. Makeup Water Treatment System</b>				
<b>8. Waste Water Treatment System</b>				
<b>9. Bridge Crane(s)</b>		<b>1</b>	<b>165,500</b>	<b>165,500</b>
Recip Engine Crane	165,500	1	165,500	165,500
Steam Turbine Crane				
<b>10. Station/Instrument Air Compressors</b>	<b>35,000</b>	<b>2</b>	<b>70,000</b>	<b>70,000</b>
<b>11. Recip Engine Genset(s)</b>		<b>1</b>	<b>186,800</b>	<b>186,800</b>
Emergency Generator				
Black Start Generator	186,800	1	186,800	186,800
<b>12. General Plant Instrumentation</b>	<b>115,900</b>	<b>1</b>	<b>115,900</b>	<b>115,900</b>
<b>13. Medium Voltage Equipment</b>	<b>5,320</b>	<b>1</b>	<b>5,320</b>	<b>5,320</b>
Transformers				
Circuit Breakers	5,060			
Switchgear				
Motor Control Centers				
Miscellaneous	253			
<b>14. Low Voltage Equipment</b>	<b>631,800</b>	<b>1</b>	<b>631,800</b>	<b>631,800</b>
Transformers	267,250			
Circuit Breakers	271,650			
Switchgear				
Motor Control Centers	62,850			
Miscellaneous	30,098			
<b>15. Miscellaneous Equipment</b>	<b>97,098</b>		<b>97,098</b>	<b>97,098</b>
<b>16. User-defined</b>			<b>0</b>	<b>0</b>

	Material	Units	Labor Hours	Labor Rate	Unit Cost	Quantity	Ref. Cost	Est. Cost
<b>III Civil (USD)</b>	<b>4,051,880</b>		<b>80,552</b>	<b>39.02</b>			<b>7,195,272</b>	<b>12,961,491</b>
<b>1. Site Work</b>	<b>1,411,000</b>		<b>20,550</b>	<b>39.00</b>			<b>2,212,450</b>	<b>8,897,881</b>
Site Clearing	included		included					
Demolition	included		included					
Culverts & Drainage	included		included					
Erosion Control	included		included					
Fencing, Controlled Access Gates	included		included					
Finish Grading	included		included					
Finish Landscaping	included		included					
Material (Dirt, Sand, Stone)	included		included					
Waste Material Removal	included		included					
Obstacles R&R	included		included					
Soil Improvements								7,000,000
<b>2. Excavation &amp; Backfill</b>	<b>201,980</b>	<b>CY</b>	<b>4,123</b>	<b>39.00</b>	<b>61.69</b>	<b>5,881</b>	<b>362,772</b>	<b>299,661</b>
Recip Engine (9)	33.45	CY	0.69	39.00	60.39	2,360	142,520	117,569
Steam Turbine (0)								
Exhaust System (9)	47.60	CY	0.98	39.00	85.89	496	42,603	35,148
Water Cooled Condenser (0)								
Cooling Tower								
Air Cooled Condenser								
Underground Piping	27.73	CY	0.55	39.00	49.22	978	48,141	39,890
Switchyard	48.22	CY	1.00	39.00	87.10	57	4,968	4,097
Other & Miscellaneous	34.95	CY	0.71	39.00	62.58	1,990	124,540	102,956
<b>3. Concrete</b>	<b>2,175,100</b>	<b>CY</b>	<b>55,090</b>	<b>39.00</b>	<b>1,172.89</b>	<b>3,686</b>	<b>4,323,611</b>	<b>3,480,320</b>
Recip Engine (9)	538.71	CY	12.47	39.00	1,025.16	1,860	1,906,800	1,551,666
Steam Turbine (0)								
Laydown pads:								
Exhaust System (9)	839.71	CY	22.96	39.00	1,735.01	345	598,580	477,345
Water Cooled Condenser (0)								
Cooling Tower								
Air Cooled Condenser								
Underground Piping:								
Makeup Water Treatment System								
Auxiliary Boiler (0)								
Electrical Power Equipment	624.45	CY	17.28	39.00	1,298.50	681	884,280	704,111
Inlet Chilling System (0)								
Fuel Gas Compressor (0)								
Pumps (2)	810.71	CY	21.43	39.00	1,646.57	3	4,610	3,692
Auxiliary Heat Exchangers	831.45	CY	22.56	39.00	1,711.35	15	25,790	20,585
Feedwater Heater(s) (0)								
Station/Instrument Air Compressors (2)	1,097.14	CY	27.37	39.00	2,164.45	8	17,558	14,160
Bridge Crane(s)								0
Recip Engine Genset(s) (1)	993.97	CY	26.01	39.00	2,008.39	17	33,279	26,681
Tanks:	484.05	CY	13.82	39.00	1,022.86	304	310,950	246,659
Switchyard	665.83	CY	18.90	39.00	1,403.04	44	61,383	48,724
Miscellaneous	589.51	CY	14.93	39.00	1,171.66	410	480,380	386,698
<b>4. Roads, Parking, Walkways</b>	<b>263,800</b>		<b>789</b>	<b>41.37</b>	<b>6.47</b>	<b>45,784</b>	<b>296,440</b>	<b>283,629</b>
Pavement, Curbing, Striping	4.19	ft^2	0.01	39.00	4.60	45,770	210,350	203,049
Lighting	5,146.43		22.29	45.00	6,149.29	14	86,090	80,579
<b>5. User-defined</b>							<b>0</b>	<b>0</b>

\* NOTE: Individual items listed in III.2-4 are per unit quantity.

	Material	Units	Labor Hours	Labor Rate	Unit Cost	Quantity	Ref. Cost	Est. Cost
<b>IV Mechanical (USD)</b>	<b>4,913,190</b>		<b>120,663</b>	<b>44.00</b>			<b>10,222,362</b>	<b>7,540,735</b>
<b>1. On-Site Transportation &amp; Rigging</b>	<b>3,046,000</b>						<b>3,046,000</b>	<b>2,448,223</b>
<b>2. Equipment Erection &amp; Assembly</b>	<b>690,700</b>		<b>82,110</b>	<b>44.00</b>			<b>4,303,540</b>	<b>2,885,500</b>
Recip Engine Package	47,860		5,690	44.00	298,220	9	2,683,980	1,799,583
Steam Turbine Package								
Exhaust System	7,480		890	44.00	46,640	9	419,760	281,427
Condenser								
Cooling Tower								
Makeup Water Treatment System								
Auxiliary Boiler								
Electrical Power Equipment	97,100		11,540	44.00			604,860	405,564
Inlet Chilling System								
Fuel Gas Compressor								
Pumps	6,600		784	44.00			41,096	27,556
Tanks + Auxiliary Heat Exchangers	20,290		2,410	44.00			126,330	84,709
Feedwater Heater(s)								
Station/Instrument Air Compressors	1,700		202	44.00			10,588	7,099
Bridge Crane(s)	2,520		300	44.00			15,720	10,539
Recip Engine Genset(s)	1,630		194	44.00			10,166	6,816
Miscellaneous	62,800		7,460	44.00			391,040	262,206
<b>3. Piping</b>	<b>917,890</b>		<b>35,743</b>	<b>44.00</b>	<b>188.11</b>	<b>13,240</b>	<b>2,490,582</b>	<b>1,873,300</b>
High Pressure Steam								
Cold Reheat Steam								
Hot Reheat Steam								
Intermediate Pressure Steam								
Low Pressure Steam								
Other Steam								
Circulating Water								
Auxiliary Cooling Water	56.87	ft	2.13	44.00	150.54	3,340	502,790	380,000
Feedwater								
Other Water								
Inlet Chilling/Heating System								
Raw Water								
Service Water	59.43	ft	2.21	44.00	156.52	716	112,070	84,783
Waste Water								
Steam/Water Sampling								
Sanitary Water								
Vents								
Fuel Gas	132.80	ft	4.49	44.00	330.32	1,820	601,180	460,084
Fuel Oil	79.89	ft	3.40	44.00	229.54	1,820	417,760	310,859
Lube Oil	148.74	ft	6.84	44.00	449.48	594	266,990	196,874
Compressed Air								
Air Bleed								
Service Air	18.16	ft	1.35	44.00	77.56	537	41,650	29,129
Vacuum Air								
Trim								
Chemical Feed								
Nitrogen								
Oxygen								
Carbon Dioxide								
Ammonia	38.53	ft	2.18	44.00	134.58	2,240	301,460	217,010
Caustic								
Acid								
Boiler & Equipment Drain								
Boiler Blowdown								
Air Blowoff								
Steam Blowoff								
Chemical Cleaning								
Heat Tracing								
Fire Protection	39.87	ft	0.42	44.00	58.46	1,250	73,072	63,953
Miscellaneous	69.39	ft	2.70	44.00	188.09	923	173,610	130,608
<b>4. Steel</b>	<b>258,600</b>	<b>ton</b>	<b>2,810</b>	<b>44.00</b>	<b>5,299.32</b>	<b>72</b>	<b>382,240</b>	<b>333,711</b>
Racks, Supports, Ladders, Walkways, Platforms	3,585.19	ton	38.96	44.00	5,299.32	72	382,240	333,711
<b>5. User-defined</b>							<b>0</b>	<b>0</b>

\* NOTE: Individual items listed in IV.2-4 are per unit quantity.



	Material	Labor Hours	Labor Rate	Unit Cost	Quantity	Ref. Cost	Est. Cost
<b>V Electrical (USD)</b>	<b>1,324,240</b>	<b>54,258</b>	<b>45.00</b>			<b>3,765,866</b>	<b>2,807,528</b>
<b>1. Controls</b>	<b>267,660</b>	<b>24,538</b>	<b>45.00</b>			<b>1,371,886</b>	<b>938,477</b>
Recip Engine Package	26,220	2,440	45.00	136,020.00	9	1,224,180	836,312
Steam Turbine Package							
Exhaust System	2,390	222	45.00	12,380.00	9	111,420	76,130
Condenser							
Cooling Tower							
Makeup Water Treatment System							
Auxiliary Boiler							
Electrical Power Equipment							
Inlet Chilling System							
Fuel Gas Compressor							
Pumps	3,610	336	45.00			18,730	12,795
Auxiliary Heat Exchangers							
Feedwater Heater(s)							
Station/Instrument Air Compressor	2,320	86	45.00			6,208	4,682
Bridge Crane(s)	2,010	75	45.00			5,380	4,057
Recip Engine Genset(s)	2,230	83	45.00			5,968	4,501
<b>2. Assembly &amp; Wiring</b>	<b>1,056,580</b>	<b>29,720</b>	<b>45.00</b>			<b>2,393,980</b>	<b>1,869,051</b>
Switchgear							
Motor Control Centers	96	48	45.00	2,273.06	18	40,915	25,531
Feeders	2,691	116	45.00	7,924.07	81	641,850	475,469
Medium/Low Voltage Cable Bus	13,107	207	45.00	22,424.08	27	605,450	506,717
Cable Tray	71,650	1,170	45.00	124,300.00	1	124,300	103,635
General Plant Instrumentation	598	10	45.00	1,048.94	80	83,915	69,767
Generator to Step-up Transformer Bus	4,860	75	45.00	8,250.00	9	74,250	62,275
Transformers	20,190	938	45.00	62,400.00	5	312,000	229,163
Circuit Breakers	9,442	292	45.00	22,596.15	13	293,750	226,633
Miscellaneous	96,050	2,700	45.00	217,550.00	1	217,550	169,861
<b>3. User-defined</b>						<b>0</b>	<b>0</b>

\* NOTE: Individual items listed in V.1 - 2 are per unit quantity.

	Area	Cost/Unit Area	Ref. Cost	Est. Cost
<b>VI Buildings (USD)</b>			5,936,096	17,771,137
1. Recip Engine Hall	25,215.0	175.96	4,436,832	3,566,103
2. Administration, Control Room, Machine Shop / Warehouse	10,600.0	138.86	1,471,916	1,183,053
3. Water Treatment System				
4. Guard House	200.0	136.74	27,348	21,981
5. Shore Protection				8,000,000
6. Barge Unloading Facility				5,000,000
7. Bridge to mainland				0

	Material	Labor Hours	Labor Rate	Unit Cost	Quantity	Ref. Cost	Est. Cost
<b>VII Engineering &amp; Startup (USD)</b>	167,500	5,560	105.00			4,247,300	4,247,300
1. Engineering						3,496,000	3,496,000
2. Start-Up	167,500	5,560	105.00	751,300		751,300	751,300
3. User-defined						0	0

	Ref. Cost	Est. Cost
<b>VIII Soft &amp; Miscellaneous Costs (USD)</b>	<b>39,937,737</b>	<b>36,037,441</b>
<b>1. Contractor's Soft Costs</b>	<b>27,839,855</b>	<b>24,156,012</b>
Contingency:	11,512,716	8,353,409
Profit:	8,866,465	8,252,413
Permits, Licenses, Fees, Miscellaneous	0	0
Bonds and Insurance	2,131,621	2,157,197
Spare Parts & Materials	0	0
Contractor's Fee	5,329,053	5,392,993
<b>2. Owner's Soft Costs</b>	<b>12,097,882</b>	<b>11,881,428</b>
Permits, Licenses, Fees, Miscellaneous	2,688,418	2,640,317
Land Cost	0	0
Utility Connection Cost	0	0
Legal & Financial Costs	2,688,418	2,640,317
Escalation and Interest During Construction	5,376,836	5,280,635
Spare Parts & Materials	0	0
Project Administration & Developer's Fee	1,344,209	1,320,159
<b>3. Total of all user-defined costs displayed on each account</b>	<b>0</b>	<b>0</b>

	Multiplier
<b>Labor Rate</b>	<b>0.6075</b>
<b>Specialized Equipment</b>	<b>1.1000</b>
1. Gas Turbine Package	1.1000
2. Steam Turbine Package	1.1000
3. Heat Recovery Boiler	1.1000
4. Water-cooled Condenser	1.1000
5. Air-cooled Condenser	1.1000
6. Inlet Chilling System	1.1000
7. Fuel Gas Compressor	1.1000
8. Continuous Emissions Monitoring System	1.1000
9. Distributed Control System	1.1000
10. Transmission Voltage Equipment	1.1000
11. High (Generating) Voltage Equipment	1.1000
<b>Other Equipment</b>	<b>1.0000</b>
1. Pumps	1.0000
2. Tanks	1.0000
3. Cooling Tower	1.0000
4. Auxiliary Heat Exchangers	1.0000
5. Feedwater Heater	1.0000
6. Auxiliary Boiler	1.0000
7. Makeup Water Treatment System	1.0000
8. Waste Water Treatment System	1.0000
9. Bridge Crane(s)	1.0000
10. Station/Instrument Air Compressor	1.0000
11. Recip Engine Genset(s)	1.0000
12. General Plant Instrumentation	1.0000
13. Medium Voltage Equipment	1.0000
14. Low Voltage Equipment	1.0000
<b>Gasification Plant</b>	
1. Gasification	0.9373
2. Air Separation Unit	0.9373
3. Gas Cleanup System	0.9373
4. Gasification Plant Water Systems	0.9373
5. Gasification Plant General Facilities	0.9373
<b>Desalination Plant</b>	
1. Desalination	1.0111
<b>CO2 Capture Plant</b>	<b>0.9373</b>
<b>Commodity</b>	<b>1.0000</b>

<b>Contractor's Soft Costs</b>	<b>Percentage, %</b>	<b>+ Fixed Amount</b>
1. Contingency		
Labor	75.0	0
Specialized Equipment	3.0	0
Other Equipment	4.0	0
Commodities	6.0	0
2. Profit		
Labor	25.0	0
Specialized Equipment	7.0	0
Other Equipment	7.0	0
Commodities	7.0	0
3. Permits, Licenses, Fees & Miscellaneous	0.0	0
4. Bonds and Insurance	2.0	0
5. Spare Parts and Materials	0.0	0
6. Contractor's Fee	5.0	0
<b>Owner's Soft Costs</b>		
1. Permits, Licenses, Fees & Miscellaneous	2.0	0
2. Land Cost	0.0	0
3. Utility Connection Cost	0.0	0
4. Legal and Financial Costs	2.0	0
5. Interest During Construction	4.0	0
6. Spare Parts and Materials	0.0	0
7. Project Administration and Developer's Fee	1.0	0

## F.2 RICE 50 MMscfd

Project Cost Summary	Reference Cost	Estimated Cost	
I Specialized Equipment	120,444,000	132,488,403	USD
II Other Equipment	2,928,692	2,928,692	USD
III Civil	10,936,917	19,019,454	USD
IV Mechanical	17,066,380	12,576,706	USD
V Electrical Assembly & Wiring	6,841,803	5,136,472	USD
VI Buildings & Structures	8,904,208	20,156,757	USD
VII Engineering & Plant Startup	5,604,400	5,604,400	USD
Gasification Plant	0	0	USD
Desalination Plant	0	0	USD
CO2 Capture Plant	0	0	USD
Subtotal - Contractor's Internal Cost	172,726,399	197,910,883	USD
VIII Contractor's Soft & Miscellaneous Costs	45,815,274	41,255,279	USD
Contractor's Price	218,541,673	239,166,162	USD
IX Owner's Soft & Miscellaneous Costs	19,668,751	21,524,955	USD
Battery Storage System	0	0	USD
Total - Owner's Cost	238,210,423	260,691,117	USD
Net Plant Output	254.2	254.2	MW
Price per kW - Contractor's	860	941	USD per kW
Cost per kW - Owner's	937	1,026	USD per kW

NOTE: Following totals refer to power plant only.  
The gasification, desalination, and CO2 capture plants are not included.

Power Plant Totals (Reference Basis):	Reference Cost	Hours
Commodities	16,768,540	
Labor	19,177,960	436,546

Effective Labor Rates:	Cost per Hour
Civil Account	39.02
Mechanical Account	44.00
Electrical Account	45.00

Power Plant Buildings	% of Total Cost	Estimated Cost	Hours
Labor	50	4,452,104	
Material	50	4,452,104	
Labor Hours			109,354

	Item Cost	Unit Cost	Quantity	Ref. Cost	Est. Cost
<b>I Specialized Equipment (USD)</b>					
<b>1. Recip Engine Package</b>		6,345,000	15	120,444,000	132,488,403
Recip Engine Genset (including multi-unit discount)	5,762,000				
Inlet Filter/Silencer System (w/ elements)	included				
Evaporative Cooling System					
Inlet Fogging System					
Exhaust Stack/Silencer System					
Electrical/Control/Instrumentation Package	included				
Gas Fuel Package	included				
Liquid Fuel Package	179,350				
Fuel Heating Package					
Steam Injection Package					
Water Injection Package					
Starting Package	included				
Lube Oil Package w/ main, auxiliary & emergency pump	included				
Compressor Water Wash System					
High Voltage Generator					
OEM supplied technical oversight & services required for warranty	included				
User-defined shipping cost [7%]	403,350				
<b>2. Steam Turbine Package</b>				0	0
Turbine					
Generator					
Exhaust System					
Electrical/Control/Instrumentation Package					
Lube Oil Package w/ main, auxiliary & emergency pump					
High Voltage Generator					
OEM supplied technical oversight & services required for warranty					
User-defined shipping cost [8%]					
<b>3. Recip Engine Exhaust System</b>		816,000	15	12,240,000	13,464,000
Duct Burner & Burner Management System					
Exhaust Transition	included				
Bypass Stack					
Main Stack	128,800				
Instrumentation	included				
SCR & Aqueous Ammonia System	312,650				
CO catalytic reactor for CO reduction	173,700				
Deaerator					
Steam Vents & Water Drains					
Non-Return Valves					
Blowdown Recovery System					
Forced Circulation Pumps					
OEM supplied technical oversight & services required for warranty	included				
User-defined shipping cost [10%]	74,200				
<b>4. Water-cooled Condenser</b>				0	0
Vacuum Pump					
Steam Jet Air Ejector					
User-defined shipping cost [8%]					
<b>5. Air-cooled Condenser</b>				0	0
Tube Bundles					
Fans, Gears, and Motors					
Steam Duct & Condenser Piping					
Turbine Exhaust Transition					
Steam Jet Air Ejector					
Condensate Receiver Tank					
Support Structures					
User-defined shipping cost [8%]					
<b>6. Inlet Air Chilling / Heating System</b>				0	0
Main Chiller Unit					
Chilling / Heating Water Coil					
Chiller Cooling System					
Approximate shipping to typical US site					
<b>7. Fuel Gas Compressor</b>				0	0
Fin Fan Cooling System					
Approximate shipping to typical US site					
<b>8. Continuous Emissions Monitoring System</b>		2,555,000	1	2,555,000	2,810,500
Enclosures	included				
Electronics, Display Units, Printers & Sensors	included				
Approximate shipping to typical US site	included				
<b>9. Distributed Control System</b>				0	0
Enclosures					
Electronics, Display Units, Printers & Sensors					
Approximate shipping to typical US site					
<b>10. Transmission Voltage Equipment</b>		9,044,000	1	9,044,000	9,948,400
Transformers	8,143,000				
Circuit Breakers	471,050				
Miscellaneous Equipment	430,700				
Approximate shipping to typical US site	included				
<b>11. Generating Voltage Equipment</b>		1,430,000	1	1,430,000	1,573,000
Generator Buswork	968,900				
Circuit Breakers	393,150				
Current Limiting Reactors					
Miscellaneous Equipment	68,100				
Approximate shipping to typical US site	included				
<b>12. User-defined</b>				0	0



	Unit Cost	Quantity	Ref. Cost	Est. Cost
<b>II Other Equipment (USD)</b>			<b>2,928,692</b>	<b>2,928,692</b>
<b>1. Pumps</b>			<b>258,560</b>	<b>258,560</b>
Integral Feedwater Pump				
HP Feedwater Pump				
IP Feedwater Pump				
LP Feedwater Pump				
Condensate Forwarding Pump				
Condenser C.W. Pump				
Condenser Vacuum Pump				
Treated Water Pump				
Demin Water Pump				
Raw Water Pump 1				
Raw Water Pump 2				
Raw Water Pump 3				
GT Water Injection Pump				
GT Evap Cooler Water Pump				
Auxiliary Boiler Feedwater Pump				
Fuel Oil Unloading Pump	9,070	1	9,070	9,070
Fuel Oil Forwarding Pump	6,270	2	12,540	12,540
Aux Cooling Water Pump (closed loop)				
Diesel Fire Pump	70,500	1	70,500	70,500
Electric Fire Pump				
Jockey Fire Pump	4,450	1	4,450	4,450
Inlet Air Chiller/Heater Water Pump				
Recip Engine+Generator Lube Oil Coolant Pump	5,400	30	162,000	162,000
Generator Lube Oil Coolant Pump				
Generator Cooling Pump				
Chiller Coolant Pump				
Fuel Compressor Coolant Pump				
ST+Generator Lube Oil Coolant Pump				
ST Generator Cooling Pump				
Aux Cooling Water Pump (open loop)				
<b>2. Tanks</b>		<b>4</b>	<b>309,370</b>	<b>309,370</b>
Fuel Oil	118,650	2	237,300	237,300
Hydrous Ammonia	18,220	1	18,220	18,220
Demineralized Water				
Raw Water				
Neutralized Water				
Acid Storage				
Caustic Storage				
Waste Water				
Dedicated Fire Protection Water Storage	53,850	1	53,850	53,850
Chilled Water Storage				
Process Water Storage				
District Heating Water Storage				
<b>3. Cooling Tower</b>				
<b>4. Auxiliary Heat Exchangers</b>			<b>627,900</b>	<b>627,900</b>
Auxiliary Cooling Water Heat Exchanger				
Auxiliary Cooling Tower				
Recip Engine+Generator Lube Oil Fin Fan Cooler	20,930	30	627,900	627,900
Generator Lube Oil Fin Fan Cooler				
Generator Fin Fan Cooler				
Chiller Fin Fan Cooler				
Fuel Compressor Fin Fan Cooler				
ST+Generator Lube Oil Fin Fan Cooler				
ST Generator Fin Fan Cooler				
Miscellaneous Heat Exchangers				
<b>5. Feedwater Heater(s)</b>				<b>0</b>
<b>6. Auxiliary Boiler</b>				
<b>7. Makeup Water Treatment System</b>				
<b>8. Waste Water Treatment System</b>				
<b>9. Bridge Crane(s)</b>		<b>1</b>	<b>165,500</b>	<b>165,500</b>
Recip Engine Crane	165,500	1	165,500	165,500
Steam Turbine Crane				
<b>10. Station/Instrument Air Compressors</b>	<b>49,120</b>	<b>2</b>	<b>98,240</b>	<b>98,240</b>
<b>11. Recip Engine Genset(s)</b>		<b>1</b>	<b>186,800</b>	<b>186,800</b>
Emergency Generator				
Black Start Generator	186,800	1	186,800	186,800
<b>12. General Plant Instrumentation</b>	<b>214,050</b>	<b>1</b>	<b>214,050</b>	<b>214,050</b>
<b>13. Medium Voltage Equipment</b>	<b>8,810</b>	<b>1</b>	<b>8,810</b>	<b>8,810</b>
Transformers				
Circuit Breakers	8,390			
Switchgear				
Motor Control Centers				
Miscellaneous	419			
<b>14. Low Voltage Equipment</b>	<b>920,000</b>	<b>1</b>	<b>920,000</b>	<b>920,000</b>
Transformers	491,100			
Circuit Breakers	284,900			
Switchgear				
Motor Control Centers	100,200			
Miscellaneous	43,810			
<b>15. Miscellaneous Equipment</b>	<b>139,462</b>		<b>139,462</b>	<b>139,462</b>
<b>16. User-defined</b>			<b>0</b>	<b>0</b>

	Material	Units	Labor Hours	Labor Rate	Unit Cost	Quantity	Ref. Cost	Est. Cost
<b>III Civil (USD)</b>	<b>6,051,660</b>		<b>125,205</b>	<b>39.02</b>			<b>10,936,917</b>	<b>19,019,454</b>
<b>1. Site Work</b>	<b>1,811,000</b>		<b>26,960</b>	<b>39.00</b>			<b>2,862,440</b>	<b>12,449,750</b>
Site Clearing	included		included					
Demolition	included		included					
Culverts & Drainage	included		included					
Erosion Control	included		included					
Fencing, Controlled Access Gates	included		included					
Finish Grading	included		included					
Finish Landscaping	included		included					
Material (Dirt, Sand, Stone)	included		included					
Waste Material Removal	included		included					
Obstacles R&R	included		included					
Soil Improvements								10,000,000
<b>2. Excavation &amp; Backfill</b>	<b>320,660</b>	<b>CY</b>	<b>6,556</b>	<b>39.00</b>	<b>61.99</b>	<b>9,297</b>	<b>576,345</b>	<b>475,989</b>
Recip Engine (15)	33.47	CY	0.69	39.00	60.37	3,930	237,240	195,757
Steam Turbine (0)								
Exhaust System (15)	47.59	CY	0.98	39.00	85.84	827	70,989	58,575
Water Cooled Condenser (0)								
Cooling Tower								
Air Cooled Condenser								
Underground Piping	27.67	CY	0.55	39.00	49.10	1,210	59,415	49,236
Switchyard	48.31	CY	1.00	39.00	87.28	80	6,991	5,766
Other & Miscellaneous	34.58	CY	0.70	39.00	62.06	3,250	201,710	166,656
<b>3. Concrete</b>	<b>3,583,100</b>	<b>CY</b>	<b>90,690</b>	<b>39.00</b>	<b>1,167.08</b>	<b>6,101</b>	<b>7,120,010</b>	<b>5,731,773</b>
Recip Engine (15)	538.71	CY	12.47	39.00	1,025.20	3,100	3,178,130	2,586,189
Steam Turbine (0)								
Laydown pads:								
Exhaust System (15)	838.28	CY	22.92	39.00	1,732.03	576	997,650	795,591
Water Cooled Condenser (0)								
Cooling Tower								
Air Cooled Condenser								
Underground Piping:								
Makeup Water Treatment System								
Auxiliary Boiler (0)								
Electrical Power Equipment	625.93	CY	17.34	39.00	1,302.04	1,130	1,471,310	1,171,436
Inlet Chilling System (0)								
Fuel Gas Compressor (0)								
Pumps (2)	810.71	CY	21.43	39.00	1,646.57	3	4,610	3,692
Auxiliary Heat Exchangers	831.21	CY	22.57	39.00	1,711.50	25	42,993	34,314
Feedwater Heater(s) (0)								
Station/Instrument Air Compressors (2)	1,114.36	CY	27.63	39.00	2,191.95	11	23,958	19,335
Bridge Crane(s)								0
Recip Engine Genset(s) (1)	993.97	CY	26.01	39.00	2,008.39	17	33,279	26,681
Tanks:	474.70	CY	13.59	39.00	1,004.88	498	500,430	396,798
Switchyard	588.47	CY	16.38	39.00	1,227.20	62	76,430	60,816
Miscellaneous	586.30	CY	14.85	39.00	1,165.27	679	791,220	636,920
<b>4. Roads, Parking, Walkways</b>	<b>336,900</b>		<b>999</b>	<b>41.27</b>	<b>6.42</b>	<b>58,917</b>	<b>378,121</b>	<b>361,942</b>
Pavement, Curbing, Striping	4.24	ft^2	0.01	39.00	4.65	58,900	273,661	264,158
Lighting	5,144.12		22.24	45.00	6,144.71	17	104,460	97,784
<b>5. User-defined</b>							<b>0</b>	<b>0</b>

\* NOTE: Individual items listed in III.2-4 are per unit quantity.

	Material	Units	Labor Hours	Labor Rate	Unit Cost	Quantity	Ref. Cost	Est. Cost
<b>IV Mechanical (USD)</b>	<b>7,974,220</b>		<b>206,640</b>	<b>44.00</b>			<b>17,066,380</b>	<b>12,576,706</b>
<b>1. On-Site Transportation &amp; Rigging</b>	<b>4,693,000</b>						<b>4,693,000</b>	<b>3,771,999</b>
<b>2. Equipment Erection &amp; Assembly</b>	<b>1,175,350</b>		<b>139,731</b>	<b>44.00</b>			<b>7,323,514</b>	<b>4,910,360</b>
Recip Engine Package	47,860		5,690	44.00	298,220	15	4,473,300	2,999,306
Steam Turbine Package								
Exhaust System	7,480		890	44.00	46,640	15	699,600	469,046
Condenser								
Cooling Tower								
Makeup Water Treatment System								
Auxiliary Boiler								
Electrical Power Equipment	190,250		22,610	44.00			1,185,090	794,615
Inlet Chilling System								
Fuel Gas Compressor								
Pumps	10,050		1,190	44.00			62,410	41,859
Tanks + Auxiliary Heat Exchangers	31,960		3,800	44.00			199,160	133,534
Feedwater Heater(s)								
Station/Instrument Air Compressors	1,990		237	44.00			12,418	8,325
Bridge Crane(s)	2,520		300	44.00			15,720	10,539
Recip Engine Genset(s)	1,630		194	44.00			10,166	6,816
Miscellaneous	106,850		12,700	44.00			665,650	446,321
<b>3. Piping</b>	<b>1,549,470</b>		<b>60,859</b>	<b>44.00</b>	<b>182.42</b>	<b>23,173</b>	<b>4,227,266</b>	<b>3,176,231</b>
High Pressure Steam								
Cold Reheat Steam								
Hot Reheat Steam								
Intermediate Pressure Steam								
Low Pressure Steam								
Other Steam								
Circulating Water								
Auxiliary Cooling Water	56.93	ft	2.13	44.00	150.71	5,560	837,950	633,300
Feedwater								
Other Water								
Inlet Chilling/Heating System								
Raw Water								
Service Water	61.32	ft	2.22	44.00	158.93	870	138,270	104,939
Waste Water								
Steam/Water Sampling								
Sanitary Water								
Vents								
Fuel Gas	137.54	ft	4.63	44.00	341.23	2,860	975,910	747,255
Fuel Oil	87.69	ft	3.53	44.00	243.08	2,860	695,200	520,773
Lube Oil	148.69	ft	6.83	44.00	449.13	990	444,640	327,895
Compressed Air								
Air Bleed								
Service Air	17.79	ft	1.32	44.00	75.94	653	49,592	34,688
Vacuum Air								
Trim								
Chemical Feed								
Nitrogen								
Oxygen								
Carbon Dioxide								
Ammonia	34.21	ft	1.80	44.00	113.47	6,240	708,060	513,945
Caustic								
Acid								
Boiler & Equipment Drain								
Boiler Blowdown								
Air Blowoff								
Steam Blowoff								
Chemical Cleaning								
Heat Tracing								
Fire Protection	36.18	ft	0.41	44.00	54.31	1,520	82,544	71,733
Miscellaneous	66.73	ft	2.62	44.00	182.16	1,620	295,100	221,703
<b>4. Steel</b>	<b>556,400</b>	<b>ton</b>	<b>6,050</b>	<b>44.00</b>	<b>5,307.10</b>	<b>155</b>	<b>822,600</b>	<b>718,116</b>
Racks, Supports, Ladders, Walkways, Platforms	3,589.68	ton	39.03	44.00	5,307.10	155	822,600	718,116
<b>5. User-defined</b>							<b>0</b>	<b>0</b>

\* NOTE: Individual items listed in IV.2-4 are per unit quantity.

	Material	Labor Hours	Labor Rate	Unit Cost	Quantity	Ref. Cost	Est. Cost
<b>V Electrical (USD)</b>	<b>2,497,010</b>	<b>96,551</b>	<b>45.00</b>			<b>6,841,803</b>	<b>5,136,472</b>
<b>1. Controls</b>	<b>441,620</b>	<b>40,701</b>	<b>45.00</b>			<b>2,273,163</b>	<b>1,554,282</b>
Gas Turbine Package	26,220	2,440	45.00	136,020.00	15	2,040,300	1,393,853
Steam Turbine Package							
GT Exhaust System	2,390	222	45.00	12,380.00	15	185,700	126,884
Condenser							
Cooling Tower							
Makeup Water Treatment System							
Auxiliary Boiler							
Electrical Power Equipment							
Inlet Chilling System							
Fuel Gas Compressor							
Pumps	5,500	512	45.00			28,540	19,497
Auxiliary Heat Exchangers							
Feedwater Heater(s)							
Station/Instrument Air Compressor	2,730	101	45.00			7,275	5,491
Bridge Crane(s)	2,010	75	45.00			5,380	4,057
Recip Engine Genset(s)	2,230	83	45.00			5,968	4,501
<b>2. Assembly &amp; Wiring</b>	<b>2,055,390</b>	<b>55,850</b>	<b>45.00</b>			<b>4,568,640</b>	<b>3,582,189</b>
Switchgear							
Motor Control Centers	91	46	45.00	2,176.33	30	65,290	40,739
Feeders	3,141	135	45.00	9,226.56	128	1,181,000	875,262
Medium/Low Voltage Cable Bus	16,433	261	45.00	28,173.33	45	1,267,800	1,060,442
Cable Tray	163,550	3,130	45.00	304,400.00	1	304,400	249,116
General Plant Instrumentation	759	13	45.00	1,330.97	155	206,300	171,505
Generator to Step-up Transformer Bus	4,860	75	45.00	8,250.00	15	123,750	103,791
Transformers	18,839	876	45.00	58,238.89	9	524,150	384,970
Circuit Breakers	9,552	296	45.00	22,880.95	21	480,500	370,639
Miscellaneous	186,850	5,080	45.00	415,450.00	1	415,450	325,725
<b>3. User-defined</b>						<b>0</b>	<b>0</b>

\* NOTE: Individual items listed in V.1 - 2 are per unit quantity.

	Area	Units	Cost/Unit Area	Ref. Cost	Est. Cost
<b>VI Buildings (USD)</b>				<b>8,904,208</b>	<b>20,156,757</b>
1. Recip Engine Hall	40,952.0	ft^2	175.22	7,175,609	5,767,396
2. Administration, Control Room, Machine Shop / Warehouse	12,500.0	ft^2	136.10	1,701,250	1,367,380
3. Water Treatment System					
4. Guard House	200.0	ft^2	136.74	27,348	21,981
5. Shore Protection					8,000,000
6. Barge Unloading Facility					5,000,000
7. Bridge to Mainland					0

	Material	Labor Hours	Labor Rate	Unit Cost	Quantity	Ref. Cost	Est. Cost
<b>VII Engineering &amp; Startup (USD)</b>	245,650	8,150	105.00			5,604,400	5,604,400
1. Engineering						4,503,000	4,503,000
2. Start-Up	245,650	8,150	105.00	1,101,400		1,101,400	1,101,400
3. User-defined						0	0

	Ref. Cost	Est. Cost
<b>VIII Soft &amp; Miscellaneous Costs (USD)</b>	<b>65,484,024</b>	<b>62,780,234</b>
<b>1. Contractor's Soft Costs</b>	<b>45,815,274</b>	<b>41,255,279</b>
Contingency:	19,120,050	13,835,870
Profit:	14,604,376	13,565,647
Permits, Licenses, Fees, Miscellaneous	0	0
Bonds and Insurance	3,454,528	3,958,218
Spare Parts & Materials	0	0
Contractor's Fee	8,636,320	9,895,544
<b>2. Owner's Soft Costs</b>	<b>19,668,751</b>	<b>21,524,955</b>
Permits, Licenses, Fees, Miscellaneous	4,370,833	4,783,323
Land Cost	0	0
Utility Connection Cost	0	0
Legal & Financial Costs	4,370,833	4,783,323
Escalation and Interest During Construction	8,741,667	9,566,646
Spare Parts & Materials	0	0
Project Administration & Developer's Fee	2,185,417	2,391,662
<b>3. Total of all user-defined costs displayed on each account</b>	<b>0</b>	<b>0</b>

	Multiplier
<b>Labor Rate</b>	<b>0.6075</b>
<b>Specialized Equipment</b>	<b>1.1000</b>
1. Gas Turbine Package	1.1000
2. Steam Turbine Package	1.1000
3. Heat Recovery Boiler	1.1000
4. Water-cooled Condenser	1.1000
5. Air-cooled Condenser	1.1000
6. Inlet Chilling System	1.1000
7. Fuel Gas Compressor	1.1000
8. Continuous Emissions Monitoring System	1.1000
9. Distributed Control System	1.1000
10. Transmission Voltage Equipment	1.1000
11. High (Generating) Voltage Equipment	1.1000
<b>Other Equipment</b>	<b>1.0000</b>
1. Pumps	1.0000
2. Tanks	1.0000
3. Cooling Tower	1.0000
4. Auxiliary Heat Exchangers	1.0000
5. Feedwater Heater	1.0000
6. Auxiliary Boiler	1.0000
7. Makeup Water Treatment System	1.0000
8. Waste Water Treatment System	1.0000
9. Bridge Crane(s)	1.0000
10. Station/Instrument Air Compressor	1.0000
11. Recip Engine Genset(s)	1.0000
12. General Plant Instrumentation	1.0000
13. Medium Voltage Equipment	1.0000
14. Low Voltage Equipment	1.0000
<b>Gasification Plant</b>	
1. Gasification	0.9373
2. Air Separation Unit	0.9373
3. Gas Cleanup System	0.9373
4. Gasification Plant Water Systems	0.9373
5. Gasification Plant General Facilities	0.9373
<b>Desalination Plant</b>	
1. Desalination	1.0111
<b>CO2 Capture Plant</b>	<b>0.9373</b>
<b>Commodity</b>	<b>1.0000</b>

<b>Contractor's Soft Costs</b>	Percentage, %	+ Fixed Amount
1. Contingency		
Labor	75.0	0
Specialized Equipment	3.0	0
Other Equipment	4.0	0
Commodities	6.0	0
2. Profit		
Labor	25.0	0
Specialized Equipment	7.0	0
Other Equipment	7.0	0
Commodities	7.0	0



3. Permits, Licenses, Fees & Miscellaneous	0.0	0
4. Bonds and Insurance	2.0	0
5. Spare Parts and Materials	0.0	0
6. Contractor's Fee	5.0	0
<b>Owner's Soft Costs</b>		
1. Permits, Licenses, Fees & Miscellaneous	2.0	0
2. Land Cost	0.0	0
3. Utility Connection Cost	0.0	0
4. Legal and Financial Costs	2.0	0
5. Interest During Construction	4.0	0
6. Spare Parts and Materials	0.0	0
7. Project Administration and Developer's Fee	1.0	0

**F.3 LM2500 Combined Cycle 30 MMscfd**

<b>Project Cost Summary</b>	<b>Reference Cost</b>	<b>Estimated Cost</b>	
I Specialized Equipment	117,276,900	129,004,593	USD
II Other Equipment	9,624,888	9,624,888	USD
III Civil	14,154,310	18,703,642	USD
IV Mechanical	18,025,764	13,311,869	USD
V Electrical Assembly & Wiring	6,590,923	4,971,196	USD
VI Buildings & Structures	1,646,838	14,323,646	USD
VII Engineering & Plant Startup	12,047,150	12,047,150	USD
<b>Gasification Plant</b>	<b>0</b>	<b>0</b>	<b>USD</b>
<b>Desalination Plant</b>	<b>0</b>	<b>0</b>	<b>USD</b>
<b>CO2 Capture Plant</b>	<b>0</b>	<b>0</b>	<b>USD</b>
<b>Subtotal - Contractor's Internal Cost</b>	<b>179,366,773</b>	<b>201,986,984</b>	<b>USD</b>
<b>VIII Contractor's Soft &amp; Miscellaneous Costs</b>	<b>50,089,904</b>	<b>44,046,589</b>	<b>USD</b>
<b>Contractor's Price</b>	<b>229,456,677</b>	<b>246,033,573</b>	<b>USD</b>
<b>IX Owner's Soft &amp; Miscellaneous Costs</b>	<b>20,651,101</b>	<b>22,143,022</b>	<b>USD</b>
<b>Battery Storage System</b>	<b>0</b>	<b>0</b>	<b>USD</b>
<b>Total - Owner's Cost</b>	<b>250,107,778</b>	<b>268,176,594</b>	<b>USD</b>
<b>Net Plant Output</b>	<b>182.6</b>	<b>182.6</b>	<b>MW</b>
<b>Price per kW - Contractor's</b>	<b>1,257</b>	<b>1,348</b>	<b>USD per kW</b>
<b>Cost per kW - Owner's</b>	<b>1,370</b>	<b>1,469</b>	<b>USD per kW</b>

**NOTE:** Following totals refer to power plant only.  
The gasification, desalination, and CO2 capture plants are not included.

<b>Power Plant Totals (Reference Basis):</b>	<b>Reference Cost</b>	<b>Hours</b>
Commodities	17,913,040	
Labor	22,419,107	509,566

<b>Effective Labor Rates:</b>	<b>Cost per Hour</b>
Civil Account	39.01
Mechanical Account	44.00
Electrical Account	45.00

<b>Power Plant Buildings</b>	<b>% of Total Cost</b>	<b>Estimated Cost</b>	<b>Hours</b>
Labor	50	823,419	
Material	50	823,419	
Labor Hours			20,227

	Item Cost	Unit Cost	Quantity	Ref. Cost	Est. Cost
<b>I Specialized Equipment (USD)</b>				<b>117,276,900</b>	<b>129,004,593</b>
<b>1. Gas Turbine Package</b>		<b>9,866,000</b>	<b>6</b>	<b>59,196,000</b>	<b>65,115,601</b>
Combustion Turbine Genset (including multi-unit discount)	8,908,000				
Inlet Filter/Silencer System (w/ elements)	included				
Evaporative Cooling System	62,500				
Inlet Fogging System					
Exhaust Stack/Silencer System					
Electrical/Control/Instrumentation Package	included				
Gas Fuel Package	included				
Liquid Fuel Package	227,650				
Fuel Heating Package	44,360				
Steam Injection Package					
Water Injection Package					
Starting Package	included				
Lube Oil Package w/ main, auxiliary & emergency pump	included				
Compressor Water Wash System	included				
High Voltage Generator					
OEM supplied technical oversight & services required for warranty	included				
User-defined shipping cost [7%]	623,600				
<b>2. Steam Turbine Package</b>		<b>5,241,000</b>	<b>3</b>	<b>15,723,000</b>	<b>17,295,300</b>
Turbine	included				
Generator	included				
Exhaust System	included				
Electrical/Control/Instrumentation Package	included				
Lube Oil Package w/ main, auxiliary & emergency pump	included				
High Voltage Generator					
OEM supplied technical oversight & services required for warranty	included				
User-defined shipping cost [8%]	388,250				
<b>3. Heat Recovery Boiler</b>		<b>3,966,000</b>	<b>6</b>	<b>23,796,000</b>	<b>26,175,601</b>
Duct Burner & Burner Management System					
Gas Turbine Exhaust Transition	included				
Bypass Stack					
Main Stack	395,250				
Instrumentation	included				
SCR & Aqueous Ammonia System	503,900				
CO catalytic reactor for CO reduction	279,950				
Deaerator	included				
Steam Vents & Water Drains	included				
Non-Return Valves	included				
Blowdown Recovery System					
Forced Circulation Pumps					
OEM supplied technical oversight & services required for warranty	included				
User-defined shipping cost [10%]	360,550				
<b>4. Water-cooled Condenser</b>		<b>611,200</b>	<b>3</b>	<b>1,833,600</b>	<b>2,016,960</b>
Vacuum Pump	elsewhere				
Steam Jet Air Ejector					
User-defined shipping cost [8%]	45,280				
<b>5. Air-cooled Condenser</b>				<b>0</b>	<b>0</b>
Tube Bundles					
Fans, Gears, and Motors					
Steam Duct & Condenser Piping					
Turbine Exhaust Transition					
Steam Jet Air Ejector					
Condensate Receiver Tank					
Support Structures					
User-defined shipping cost [8%]					
<b>6. Inlet Air Chilling / Heating System</b>				<b>0</b>	<b>0</b>
Main Chiller Unit					
Chilling / Heating Water Coil					
Chiller Cooling System					
Approximate shipping to typical US site					
<b>7. Fuel Gas Compressor</b>		<b>828,500</b>	<b>2</b>	<b>1,657,000</b>	<b>1,822,700</b>
Fin Fan Cooling System					
Approximate shipping to typical US site	included				
<b>8. Continuous Emissions Monitoring System</b>		<b>1,812,000</b>	<b>1</b>	<b>1,812,000</b>	<b>1,993,200</b>
Enclosures	included				
Electronics, Display Units, Printers & Sensors	included				
Approximate shipping to typical US site	included				
<b>9. Distributed Control System</b>		<b>630,000</b>	<b>1</b>	<b>630,000</b>	<b>693,000</b>
Enclosures	included				
Electronics, Display Units, Printers & Sensors	included				
Approximate shipping to typical US site	included				
<b>10. Transmission Voltage Equipment</b>		<b>11,637,000</b>	<b>1</b>	<b>11,637,000</b>	<b>12,800,700</b>
Transformers	10,659,000				
Circuit Breakers	423,650				
Miscellaneous Equipment	554,100				
Approximate shipping to typical US site	included				
<b>11. Generating Voltage Equipment</b>		<b>992,300</b>	<b>1</b>	<b>992,300</b>	<b>1,091,530</b>
Generator Buswork	665,400				
Circuit Breakers	279,650				
Current Limiting Reactors					
Miscellaneous Equipment	47,250				
Approximate shipping to typical US site	included				
<b>12. User-defined</b>				<b>0</b>	<b>0</b>

	Unit Cost	Quantity	Ref. Cost	Est. Cost
<b>II Other Equipment (USD)</b>			<b>9,624,888</b>	<b>9,624,888</b>
<b>1. Pumps</b>			<b>3,848,560</b>	<b>3,848,560</b>
Integral Feedwater Pump				
HP Feedwater Pump	149,000	18	2,682,000	2,682,000
IP Feedwater Pump	26,170	18	471,060	471,060
LP Feedwater Pump				
Condensate Forwarding Pump	7,500	6	45,000	45,000
Condenser C.W. Pump	63,250	6	379,500	379,500
Condenser Vacuum Pump	21,190	6	127,140	127,140
Treated Water Pump	4,080	1	4,080	4,080
Demin Water Pump				
Raw Water Pump 1	3,900	1	3,900	3,900
Raw Water Pump 2	3,900	1	3,900	3,900
Raw Water Pump 3	3,900	1	3,900	3,900
GT Water Injection Pump				
GT Evap Cooler Water Pump	elsewhere			
Auxiliary Boiler Feedwater Pump				
Fuel Oil Unloading Pump	9,070	1	9,070	9,070
Fuel Oil Forwarding Pump	5,370	2	10,740	10,740
Aux Cooling Water Pump (closed loop)	8,330	2	16,660	16,660
Diesel Fire Pump	70,500	1	70,500	70,500
Electric Fire Pump				
Jockey Fire Pump	4,450	1	4,450	4,450
GT Inlet Air Chiller/Heater Water Pump				
GT Lube Oil Coolant Pump				
GT Generator Lube Oil Coolant Pump				
GT Generator Cooling Pump				
GT Chiller Coolant Pump				
Fuel Compressor Coolant Pump				
ST+Generator Lube Oil Coolant Pump				
ST Generator Cooling Pump				
Aux Cooling Water Pump (open loop)	8,330	2	16,660	16,660
<b>2. Tanks</b>		<b>9</b>	<b>319,980</b>	<b>319,980</b>
Fuel Oil	86,800	2	173,600	173,600
Hydrous Ammonia	12,690	1	12,690	12,690
Demineralized Water	28,020	1	28,020	28,020
Raw Water	28,020	1	28,020	28,020
Neutralized Water	18,460	1	18,460	18,460
Acid Storage	2,670	1	2,670	2,670
Caustic Storage	2,670	1	2,670	2,670
Waste Water				
Dedicated Fire Protection Water Storage	53,850	1	53,850	53,850
Chilled Water Storage				
Process Water Storage				
District Heating Water Storage				
<b>3. Cooling Tower</b>	<b>1,488,000</b>	<b>1</b>	<b>1,488,000</b>	<b>1,488,000</b>
<b>4. Auxiliary Heat Exchangers</b>			<b>42,910</b>	<b>42,910</b>
Auxiliary Cooling Water Heat Exchanger	42,910	1	42,910	42,910
Auxiliary Cooling Tower				
GT Lube Oil Fin Fan Cooler				
GT Generator Lube Oil Fin Fan Cooler				
GT Generator Fin Fan Cooler				
GT Chiller Fin Fan Cooler				
Fuel Compressor Fin Fan Cooler				
ST+Generator Lube Oil Fin Fan Cooler				
ST Generator Fin Fan Cooler				
Miscellaneous Heat Exchangers				
<b>5. Feedwater Heater(s)</b>				<b>0</b>
<b>6. Auxiliary Boiler</b>				
<b>7. Makeup Water Treatment System</b>	<b>861,200</b>	<b>1</b>	<b>861,200</b>	<b>861,200</b>
<b>8. Waste Water Treatment System</b>	<b>58,850</b>	<b>1</b>	<b>58,850</b>	<b>58,850</b>
<b>9. Bridge Crane(s)</b>		<b>2</b>	<b>541,050</b>	<b>541,050</b>
Gas Turbine Crane	343,250	1	343,250	343,250
Steam Turbine Crane	197,800	1	197,800	197,800
<b>10. Station/Instrument Air Compressors</b>	<b>38,680</b>	<b>2</b>	<b>77,360</b>	<b>77,360</b>
<b>11. Recip Engine Genset(s)</b>		<b>1</b>	<b>233,500</b>	<b>233,500</b>
Emergency Generator				
Black Start Generator	233,500	1	233,500	233,500
<b>12. General Plant Instrumentation</b>	<b>191,500</b>	<b>1</b>	<b>191,500</b>	<b>191,500</b>
<b>13. Medium Voltage Equipment</b>	<b>410,650</b>	<b>1</b>	<b>410,650</b>	<b>410,650</b>
Transformers	97,200			
Circuit Breakers	15,720			
Switchgear	185,800			
Motor Control Centers	92,400			
Miscellaneous	19,560			
<b>14. Low Voltage Equipment</b>	<b>1,093,000</b>	<b>1</b>	<b>1,093,000</b>	<b>1,093,000</b>
Transformers	401,350			
Circuit Breakers	410,350			
Switchgear				
Motor Control Centers	229,050			
Miscellaneous	52,050			
<b>15. Miscellaneous Equipment</b>	<b>458,328</b>		<b>458,328</b>	<b>458,328</b>
<b>16. User-defined</b>			<b>0</b>	<b>0</b>

	Material	Units	Labor Hours	Labor Rate	Unit Cost	Quantity	Ref. Cost	Est. Cost
<b>III Civil (USD)</b>	<b>7,910,570</b>		<b>160,041</b>	<b>39.01</b>			<b>14,154,310</b>	<b>18,703,642</b>
<b>1. Site Work</b>	<b>1,868,000</b>		<b>27,880</b>	<b>39.00</b>			<b>2,955,320</b>	<b>9,528,547</b>
Site Clearing	included		included					
Demolition	included		included					
Culverts & Drainage	included		included					
Erosion Control	included		included					
Fencing, Controlled Access Gates	included		included					
Finish Grading	included		included					
Finish Landscaping	included		included					
Material (Dirt, Sand, Stone)	included		included					
Waste Material Removal	included		included					
Obstacles R&R	included		included					
Soil Improvements	included		included					7,000,000
<b>2. Excavation &amp; Backfill</b>	<b>829,850</b>	<b>CY</b>	<b>16,737</b>	<b>39.00</b>	<b>54.20</b>	<b>27,356</b>	<b>1,482,608</b>	<b>1,226,400</b>
Gas Turbine (6)	33.38	CY	0.68	39.00	60.04	2,780	166,900	137,816
Steam Turbine (3)	33.50	CY	0.69	39.00	60.23	534	32,164	26,561
Heat Recovery Boiler (6)	28.50	CY	0.57	39.00	50.74	13,710	695,680	575,975
Water Cooled Condenser (3)	31.17	CY	0.62	39.00	55.54	957	53,152	43,998
Cooling Tower	32.83	CY	0.68	39.00	59.31	1,280	75,911	62,609
Air Cooled Condenser								
Underground Piping	27.99	CY	0.56	39.00	49.77	2,560	127,420	105,530
Switchyard	48.20	CY	1.00	39.00	87.12	65	5,621	4,635
Other & Miscellaneous	33.24	CY	0.67	39.00	59.55	5,470	325,760	269,275
<b>3. Concrete</b>	<b>4,889,770</b>	<b>CY</b>	<b>114,469</b>	<b>39.00</b>	<b>1,303.37</b>	<b>7,177</b>	<b>9,354,061</b>	<b>7,601,827</b>
Gas Turbine (6)	783.89	CY	14.64	39.00	1,354.81	1,800	2,438,650	2,035,297
Steam Turbine (3)	806.58	CY	17.45	39.00	1,487.21	365	542,830	445,321
Laydown pads:	844.96	CY	22.74	39.00	1,732.01	9	15,763	12,594
Heat Recovery Boiler (6)	576.06	CY	13.24	39.00	1,092.40	1,880	2,053,710	1,672,706
Water Cooled Condenser (3)	690.25	CY	20.13	39.00	1,475.21	236	348,150	275,439
Cooling Tower	720.44	CY	20.26	39.00	1,510.73	455	687,380	546,245
Air Cooled Condenser								
Underground Piping:								
Makeup Water Treatment System	607.30	CY	16.57	39.00	1,253.71	54	68,001	54,240
Auxiliary Boiler (0)								
Electrical Power Equipment	650.90	CY	18.41	39.00	1,368.89	1,000	1,368,890	1,087,079
Inlet Chilling System (0)								
Fuel Gas Compressor (2)	1,026.23	CY	26.41	39.00	2,056.31	55	112,110	90,067
Pumps (8)	830.95	CY	21.86	39.00	1,683.37	52	87,030	69,733
Auxiliary Heat Exchangers								
Feedwater Heater(s) (0)								
Station/Instrument Air Compressors (2)	1,100.62	CY	27.40	39.00	2,169.17	9	18,605	15,008
Bridge Crane(s)								0
Recip Engine Genset(s) (1)	987.96	CY	25.94	39.00	1,999.65	20	39,853	31,939
Tanks:	545.58	CY	16.26	39.00	1,179.82	396	467,210	368,630
Switchyard	636.18	CY	17.91	39.00	1,334.65	50	66,399	52,760
Miscellaneous	681.81	CY	15.96	39.00	1,304.24	797	1,039,480	844,769
<b>4. Roads, Parking, Walkways</b>	<b>322,950</b>		<b>955</b>	<b>41.24</b>	<b>6.39</b>	<b>56,716</b>	<b>362,321</b>	<b>346,868</b>
Pavement, Curbing, Striping	4.24	ft^2	0.01	39.00	4.66	56,700	264,001	254,836
Lighting	5,143.75		22.25	45.00	6,145.00	16	98,320	92,032
<b>5. User-defined</b>							<b>0</b>	<b>0</b>

\* NOTE: Individual items listed in III.2-4 are per unit quantity.

	Material	Units	Labor Hours	Labor Rate	Unit Cost	Quantity	Ref. Cost	Est. Cost
<b>IV Mechanical (USD)</b>	<b>7,189,840</b>		<b>246,271</b>	<b>44.00</b>			<b>18,025,764</b>	<b>13,311,869</b>
<b>1. On-Site Transportation &amp; Rigging</b>	<b>2,348,000</b>						<b>2,348,000</b>	<b>1,887,205</b>
<b>2. Equipment Erection &amp; Assembly</b>	<b>1,210,820</b>		<b>141,145</b>	<b>44.00</b>			<b>7,421,200</b>	<b>4,983,626</b>
Gas Turbine Package	32,880		3,910	44.00	204,920	6	1,229,520	824,366
Steam Turbine Package	41,980		4,990	44.00	261,540	3	784,620	526,088
HRSRG	76,900		9,140	44.00	479,060	6	2,874,360	1,927,273
Condenser	12,780		1,520	44.00	79,660	3	238,980	160,229
Cooling Tower	elsewhere		elsewhere					
Makeup Water Treatment System	37,330		1,890	44.00	120,490	1	120,490	87,850
Auxiliary Boiler								
Electrical Power Equipment	162,750		19,350	44.00			1,014,150	679,976
Inlet Chilling System								
Fuel Gas Compressor	4,150		493	44.00	25,842	2	51,684	34,656
Pumps	28,840		3,430	44.00			179,760	120,524
Tanks + Auxiliary Heat Exchangers	33,200		3,950	44.00			207,000	138,784
Feedwater Heater(s)								
Station/Instrument Air Compressors	1,780		211	44.00			11,064	7,420
Bridge Crane(s)	3,830		456	44.00			23,894	16,019
Recip Engine Genset(s)	1,780		212	44.00			11,108	7,447
Miscellaneous	110,050		12,830	44.00			674,570	452,996
<b>3. Piping</b>	<b>3,293,870</b>		<b>101,456</b>	<b>44.00</b>	<b>200.39</b>	<b>38,715</b>	<b>7,757,934</b>	<b>6,005,789</b>
High Pressure Steam	289.95	ft	6.83	44.00	590.39	1,980	1,168,980	935,490
Cold Reheat Steam								
Hot Reheat Steam								
Intermediate Pressure Steam	80.59	ft	3.67	44.00	241.85	2,030	490,960	362,471
Low Pressure Steam								
Other Steam								
Circulating Water	263.64	ft	2.11	44.00	356.59	942	335,910	301,543
Auxiliary Cooling Water	33.07	ft	1.59	44.00	102.90	11,210	1,153,510	846,277
Feedwater	74.57	ft	2.88	44.00	201.26	2,900	583,650	439,445
Other Water	28.01	ft	1.47	44.00	92.81	4,760	441,790	320,727
GT Inlet Chilling/Heating System								
Raw Water	30.94	ft	1.59	44.00	100.84	598	60,300	43,894
Service Water	60.12	ft	2.19	44.00	156.59	894	139,990	106,141
Waste Water								
Steam/Water Sampling								
Sanitary Water								
Vents								
Fuel Gas	176.61	ft	4.36	44.00	368.29	1,740	640,820	509,913
Fuel Oil	82.30	ft	3.18	44.00	222.39	1,740	386,960	291,284
Lube Oil	313.33	ft	9.83	44.00	746.00	1,080	805,680	622,273
Compressed Air								
GT Air Bleed								
Service Air	18.06	ft	1.34	44.00	77.01	671	51,676	36,150
Vacuum Air	134.09	ft	3.94	44.00	307.42	264	81,160	63,199
Trim								
Chemical Feed								
Nitrogen								
Oxygen								
Carbon Dioxide								
Ammonia	38.31	ft	2.17	44.00	133.60	1,510	201,730	145,257
Caustic								
Acid								
Boiler & Equipment Drain	70.61	ft	0.53	44.00	93.77	798	74,830	67,577
Boiler Blowdown	87.16	ft	1.97	44.00	173.72	798	138,630	111,516
Air Blowoff								
Steam Blowoff	387.96	ft	7.02	44.00	696.78	540	376,260	310,807
Chemical Cleaning								
Heat Tracing								
Fire Protection	35.74	ft	0.41	44.00	53.70	1,560	83,778	72,777
Miscellaneous	85.11	ft	2.62	44.00	200.49	2,700	541,320	419,048
<b>4. Steel</b>	<b>337,150</b>	<b>ton</b>	<b>3,670</b>	<b>44.00</b>	<b>5,301.75</b>	<b>94</b>	<b>498,630</b>	<b>435,249</b>
Racks, Supports, Ladders, Walkways, Platforms	3,584.79	ton	39.02	44.00	5,301.75	94	498,630	435,249
<b>5. User-defined</b>							<b>0</b>	<b>0</b>

\* NOTE: Individual items listed in IV.2-4 are per unit quantity.

	Material	Labor Hours	Labor Rate	Unit Cost	Quantity	Ref. Cost	Est. Cost
<b>V Electrical (USD)</b>	<b>2,464,230</b>	<b>91,704</b>	<b>45.00</b>			<b>6,590,923</b>	<b>4,971,196</b>
<b>1. Controls</b>	<b>373,330</b>	<b>33,584</b>	<b>45.00</b>			<b>1,884,623</b>	<b>1,291,440</b>
Gas Turbine Package	18,010	1,670	45.00	93,160.00	6	558,960	381,982
Steam Turbine Package	23,000	2,140	45.00	119,300.00	3	357,900	244,507
HRSg	24,570	2,280	45.00	127,170.00	6	763,020	521,397
Condenser	2,880	268	45.00	14,940.00	3	44,820	30,619
Cooling Tower	elsewhere	elsewhere					
Makeup Water Treatment System	5,090	473	45.00	26,375.00	1	26,375	18,021
Auxiliary Boiler							
Electrical Power Equipment							
Inlet Chilling System							
Fuel Gas Compressor	5,690	211	45.00	15,185.00	2	30,370	22,916
Pumps	15,800	1,470	45.00			81,950	55,986
Auxiliary Heat Exchangers							
Feedwater Heater(s)							
Station/Instrument Air Compressor	2,440	91	45.00			6,517	4,917
Bridge Crane(s)	3,060	114	45.00			8,190	6,176
Recip Engine Genset(s)	2,440	91	45.00			6,521	4,919
<b>2. Assembly &amp; Wiring</b>	<b>2,090,900</b>	<b>58,120</b>	<b>45.00</b>			<b>4,706,300</b>	<b>3,679,756</b>
Switchgear	5,070	282	45.00	17,760.00	1	17,760	12,779
Motor Control Centers	231	48	45.00	2,398.16	38	91,130	58,808
Feeders	4,341	160	45.00	11,551.07	140	1,617,150	1,220,980
Medium/Low Voltage Cable Bus	13,540	240	45.00	24,330.21	48	1,167,850	964,555
Cable Tray	173,650	2,970	45.00	307,300.00	1	307,300	254,842
General Plant Instrumentation	795	13	45.00	1,393.23	155	215,950	179,565
Generator to Step-up Transformer Bus	5,150	80	45.00	8,740.00	9	78,660	65,978
Transformers	10,800	502	45.00	33,403.85	13	434,250	318,914
Circuit Breakers	9,707	301	45.00	23,236.67	15	348,550	268,892
Miscellaneous	190,100	5,280	45.00	427,700.00	1	427,700	334,442
<b>3. User-defined</b>						<b>0</b>	<b>0</b>

\* NOTE: Individual items listed in V.1 - 2 are per unit quantity.



	Area	Cost/Unit Area	Ref. Cost	Est. Cost
<b>VI Buildings (USD)</b>			1,646,838	14,323,646
1. Turbine Hall				
2. Administration, Control Room, Machine Shop / Warehouse	11,400.0	137.74	1,570,236	1,262,077
3. Water Treatment System	360.2	136.74	49,254	39,588
4. Guard House	200.0	136.74	27,348	21,981
5. Shore Protection				8,000,000
6. Barge Unloading Facility				5,000,000
7. Bridge to Mainland				0

	Material	Labor Hours	Labor Rate	Unit Cost	Quantity	Ref. Cost	Est. Cost
<b>VII Engineering &amp; Startup (USD)</b>	348,400	11,550	105.00			12,047,150	12,047,150
1. Engineering						10,486,000	10,486,000
2. Start-Up	348,400	11,550	105.00	1,561,150		1,561,150	1,561,150
3. User-defined						0	0

	Ref. Cost	Est. Cost
<b>VIII Soft &amp; Miscellaneous Costs (USD)</b>	<b>70,741,005</b>	<b>66,189,610</b>
<b>1. Contractor's Soft Costs</b>	<b>50,089,904</b>	<b>44,046,589</b>
Contingency:	21,792,415	15,544,622
Profit:	15,741,815	14,362,878
Permits, Licenses, Fees, Miscellaneous	0	0
Bonds and Insurance	3,587,335	4,039,740
Spare Parts & Materials	0	0
Contractor's Fee	8,968,339	10,099,349
<b>2. Owner's Soft Costs</b>	<b>20,651,101</b>	<b>22,143,022</b>
Permits, Licenses, Fees, Miscellaneous	4,589,134	4,920,671
Land Cost	0	0
Utility Connection Cost	0	0
Legal & Financial Costs	4,589,134	4,920,671
Escalation and Interest During Construction	9,178,267	9,841,343
Spare Parts & Materials	0	0
Project Administration & Developer's Fee	2,294,567	2,460,336
<b>3. Total of all user-defined costs displayed on each account</b>	<b>0</b>	<b>0</b>

	Multiplier
<b>Labor Rate</b>	<b>0.6075</b>
<b>Specialized Equipment</b>	<b>1.1000</b>
1. Gas Turbine Package	1.1000
2. Steam Turbine Package	1.1000
3. Heat Recovery Boiler	1.1000
4. Water-cooled Condenser	1.1000
5. Air-cooled Condenser	1.1000
6. Inlet Chilling System	1.1000
7. Fuel Gas Compressor	1.1000
8. Continuous Emissions Monitoring System	1.1000
9. Distributed Control System	1.1000
10. Transmission Voltage Equipment	1.1000
11. High (Generating) Voltage Equipment	1.1000
<b>Other Equipment</b>	<b>1.0000</b>
1. Pumps	1.0000
2. Tanks	1.0000
3. Cooling Tower	1.0000
4. Auxiliary Heat Exchangers	1.0000
5. Feedwater Heater	1.0000
6. Auxiliary Boiler	1.0000
7. Makeup Water Treatment System	1.0000
8. Waste Water Treatment System	1.0000
9. Bridge Crane(s)	1.0000
10. Station/Instrument Air Compressor	1.0000
11. Recip Engine Genset(s)	1.0000
12. General Plant Instrumentation	1.0000
13. Medium Voltage Equipment	1.0000
14. Low Voltage Equipment	1.0000
<b>Gasification Plant</b>	
1. Gasification	0.9373
2. Air Separation Unit	0.9373
3. Gas Cleanup System	0.9373
4. Gasification Plant Water Systems	0.9373
5. Gasification Plant General Facilities	0.9373
<b>Desalination Plant</b>	
1. Desalination	1.0111
<b>CO2 Capture Plant</b>	<b>0.9373</b>
<b>Commodity</b>	<b>1.0000</b>

<b>Contractor's Soft Costs</b>	<b>Percentage, %</b>	<b>+ Fixed Amount</b>
1. Contingency		
Labor	75.0	0
Specialized Equipment	3.0	0
Other Equipment	4.0	0
Commodities	6.0	0
2. Profit		
Labor	25.0	0
Specialized Equipment	7.0	0
Other Equipment	7.0	0
Commodities	7.0	0
3. Permits, Licenses, Fees & Miscellaneous	0.0	0
4. Bonds and Insurance	2.0	0
5. Spare Parts and Materials	0.0	0
6. Contractor's Fee	5.0	0
<b>Owner's Soft Costs</b>		
1. Permits, Licenses, Fees & Miscellaneous	2.0	0
2. Land Cost	0.0	0
3. Utility Connection Cost	0.0	0
4. Legal and Financial Costs	2.0	0
5. Interest During Construction	4.0	0
6. Spare Parts and Materials	0.0	0
7. Project Administration and Developer's Fee	1.0	0

**F.4 LM2500 Combined Cycle 50 MMscfd**

<b>Project Cost Summary</b>	<b>Reference Cost</b>	<b>Estimated Cost</b>	
I Specialized Equipment	194,807,500	214,288,255	USD
II Other Equipment	14,741,391	14,741,391	USD
III Civil	22,376,919	28,470,371	USD
IV Mechanical	31,495,866	23,265,088	USD
V Electrical Assembly & Wiring	12,525,136	9,557,983	USD
VI Buildings & Structures	1,899,881	14,527,030	USD
VII Engineering & Plant Startup	15,833,300	15,833,300	USD
<b>Gasification Plant</b>	<b>0</b>	<b>0</b>	<b>USD</b>
<b>Desalination Plant</b>	<b>0</b>	<b>0</b>	<b>USD</b>
<b>CO2 Capture Plant</b>	<b>0</b>	<b>0</b>	<b>USD</b>
<b>Subtotal - Contractor's Internal Cost</b>	<b>293,679,993</b>	<b>320,683,417</b>	<b>USD</b>
<b>VIII Contractor's Soft &amp; Miscellaneous Costs</b>	<b>84,068,171</b>	<b>72,804,716</b>	<b>USD</b>
<b>Contractor's Price</b>	<b>377,748,164</b>	<b>393,488,132</b>	<b>USD</b>
<b>IX Owner's Soft &amp; Miscellaneous Costs</b>	<b>33,997,335</b>	<b>35,413,932</b>	<b>USD</b>
<b>Battery Storage System</b>	<b>0</b>	<b>0</b>	<b>USD</b>
<b>Total - Owner's Cost</b>	<b>411,745,499</b>	<b>428,902,064</b>	<b>USD</b>
<b>Net Plant Output</b>	<b>304.3</b>	<b>304.3</b>	<b>MW</b>
<b>Price per kW - Contractor's</b>	<b>1,241</b>	<b>1,293</b>	<b>USD per kW</b>
<b>Cost per kW - Owner's</b>	<b>1,353</b>	<b>1,410</b>	<b>USD per kW</b>

**NOTE:** Following totals refer to power plant only.  
The gasification, desalination, and CO2 capture plants are not included.

<b>Power Plant Totals (Reference Basis):</b>	<b>Reference Cost</b>	<b>Hours</b>
Commodities	30,249,370	
Labor	38,475,851	875,689

<b>Effective Labor Rates:</b>	<b>Cost per Hour</b>
Civil Account	39.01
Mechanical Account	44.00
Electrical Account	45.00

<b>Power Plant Buildings</b>	<b>% of Total Cost</b>	<b>Estimated Cost</b>	<b>Hours</b>
Labor	50	949,941	
Material	50	949,941	
Labor Hours			23,336

	Item Cost	Unit Cost	Quantity	Ref. Cost	Est. Cost
<b>I Specialized Equipment (USD)</b>				<b>194,807,500</b>	<b>214,288,255</b>
<b>1. Gas Turbine Package</b>		<b>9,670,000</b>	<b>10</b>	<b>96,700,000</b>	<b>106,370,002</b>
Combustion Turbine Genset (including multi-unit discount)	8,731,000				
Inlet Filter/Silencer System (w/ elements)	included				
Evaporative Cooling System	61,300				
Inlet Fogging System					
Exhaust Stack/Silencer System					
Electrical/Control/Instrumentation Package	included				
Gas Fuel Package	included				
Liquid Fuel Package	223,150				
Fuel Heating Package	43,480				
Steam Injection Package					
Water Injection Package					
Starting Package	included				
Lube Oil Package w/ main, auxiliary & emergency pump	included				
Compressor Water Wash System	included				
High Voltage Generator					
OEM supplied technical oversight & services required for warranty	included				
User-defined shipping cost [7%]	611,200				
<b>2. Steam Turbine Package</b>		<b>5,043,000</b>	<b>5</b>	<b>25,215,000</b>	<b>27,736,501</b>
Turbine	included				
Generator	included				
Exhaust System	included				
Electrical/Control/Instrumentation Package	included				
Lube Oil Package w/ main, auxiliary & emergency pump	included				
High Voltage Generator					
OEM supplied technical oversight & services required for warranty	included				
User-defined shipping cost [8%]	373,550				
<b>3. Heat Recovery Boiler</b>		<b>3,999,000</b>	<b>10</b>	<b>39,990,000</b>	<b>43,989,001</b>
Duct Burner & Burner Management System					
Gas Turbine Exhaust Transition	included				
Bypass Stack					
Main Stack	395,250				
Instrumentation	included				
SCR & Aqueous Ammonia System	503,900				
CO catalytic reactor for CO reduction	279,950				
Deaerator	included				
Steam Vents & Water Drains	included				
Non-Return Valves	included				
Blowdown Recovery System					
Forced Circulation Pumps					
OEM supplied technical oversight & services required for warranty	included				
User-defined shipping cost [10%]	363,600				
<b>4. Water-cooled Condenser</b>		<b>611,300</b>	<b>5</b>	<b>3,056,500</b>	<b>3,362,150</b>
Vacuum Pump	elsewhere				
Steam Jet Air Ejector					
User-defined shipping cost [8%]	45,280				
<b>5. Air-cooled Condenser</b>				<b>0</b>	<b>0</b>
Tube Bundles					
Fans, Gears, and Motors					
Steam Duct & Condenser Piping					
Turbine Exhaust Transition					
Steam Jet Air Ejector					
Condensate Receiver Tank					
Support Structures					
User-defined shipping cost [8%]					
<b>6. Inlet Air Chilling / Heating System</b>				<b>0</b>	<b>0</b>
Main Chiller Unit					
Chilling / Heating Water Coil					
Chiller Cooling System					
Approximate shipping to typical US site					
<b>7. Fuel Gas Compressor</b>		<b>1,022,000</b>	<b>2</b>	<b>2,044,000</b>	<b>2,248,400</b>
Fin Fan Cooling System					
Approximate shipping to typical US site	included				
<b>8. Continuous Emissions Monitoring System</b>		<b>2,997,000</b>	<b>1</b>	<b>2,997,000</b>	<b>3,296,700</b>
Enclosures	included				
Electronics, Display Units, Printers & Sensors	included				
Approximate shipping to typical US site	included				
<b>9. Distributed Control System</b>		<b>1,016,000</b>	<b>1</b>	<b>1,016,000</b>	<b>1,117,600</b>
Enclosures	included				
Electronics, Display Units, Printers & Sensors	included				
Approximate shipping to typical US site	included				
<b>10. Transmission Voltage Equipment</b>		<b>22,135,000</b>	<b>1</b>	<b>22,135,000</b>	<b>24,348,501</b>
Transformers	20,451,000				
Circuit Breakers	630,000				
Miscellaneous Equipment	1,054,000				
Approximate shipping to typical US site	included				
<b>11. Generating Voltage Equipment</b>		<b>1,654,000</b>	<b>1</b>	<b>1,654,000</b>	<b>1,819,400</b>
Generator Buswork	1,109,000				
Circuit Breakers	466,050				
Current Limiting Reactors					
Miscellaneous Equipment	78,750				
Approximate shipping to typical US site	included				
<b>12. User-defined</b>				<b>0</b>	<b>0</b>

	Unit Cost	Quantity	Ref. Cost	Est. Cost
<b>II Other Equipment (USD)</b>			<b>14,741,391</b>	<b>14,741,391</b>
<b>1. Pumps</b>			<b>6,347,120</b>	<b>6,347,120</b>
Integral Feedwater Pump				
HP Feedwater Pump	149,000	30	4,470,000	4,470,000
IP Feedwater Pump	26,230	30	786,900	786,900
LP Feedwater Pump				
Condensate Forwarding Pump	7,500	10	75,000	75,000
Condenser C.W. Pump	63,250	10	632,500	632,500
Condenser Vacuum Pump	21,190	10	211,900	211,900
Treated Water Pump	5,180	1	5,180	5,180
Demin Water Pump	4,690	2	9,380	9,380
Raw Water Pump 1	4,940	1	4,940	4,940
Raw Water Pump 2	4,940	1	4,940	4,940
Raw Water Pump 3	4,940	1	4,940	4,940
GT Water Injection Pump				
GT Evap Cooler Water Pump	elsewhere			
Auxiliary Boiler Feedwater Pump				
Fuel Oil Unloading Pump	9,070	1	9,070	9,070
Fuel Oil Forwarding Pump	6,370	2	12,740	12,740
Aux Cooling Water Pump (closed loop)	11,170	2	22,340	22,340
Diesel Fire Pump	70,500	1	70,500	70,500
Electric Fire Pump				
Jockey Fire Pump	4,450	1	4,450	4,450
GT Inlet Air Chiller/Heater Water Pump				
GT Lube Oil Coolant Pump				
GT Generator Lube Oil Coolant Pump				
GT Generator Cooling Pump				
GT Chiller Coolant Pump				
Fuel Compressor Coolant Pump				
ST+Generator Lube Oil Coolant Pump				
ST Generator Cooling Pump				
Aux Cooling Water Pump (open loop)	11,170	2	22,340	22,340
<b>2. Tanks</b>		<b>9</b>	<b>430,600</b>	<b>430,600</b>
Fuel Oil	123,700	2	247,400	247,400
Hydrous Ammonia	23,500	1	23,500	23,500
Demineralized Water	36,420	1	36,420	36,420
Raw Water	36,420	1	36,420	36,420
Neutralized Water	25,510	1	25,510	25,510
Acid Storage	3,750	1	3,750	3,750
Caustic Storage	3,750	1	3,750	3,750
Waste Water				
Dedicated Fire Protection Water Storage	53,850	1	53,850	53,850
Chilled Water Storage				
Process Water Storage				
District Heating Water Storage				
<b>3. Cooling Tower</b>	<b>2,480,000</b>	<b>1</b>	<b>2,480,000</b>	<b>2,480,000</b>
<b>4. Auxiliary Heat Exchangers</b>			<b>71,250</b>	<b>71,250</b>
Auxiliary Cooling Water Heat Exchanger	71,250	1	71,250	71,250
Auxiliary Cooling Tower				
GT Lube Oil Fin Fan Cooler				
GT Generator Lube Oil Fin Fan Cooler				
GT Generator Fin Fan Cooler				
GT Chiller Fin Fan Cooler				
Fuel Compressor Fin Fan Cooler				
ST+Generator Lube Oil Fin Fan Cooler				
ST Generator Fin Fan Cooler				
Miscellaneous Heat Exchangers				
<b>5. Feedwater Heater(s)</b>				<b>0</b>
<b>6. Auxiliary Boiler</b>				
<b>7. Makeup Water Treatment System</b>	<b>1,163,000</b>	<b>1</b>	<b>1,163,000</b>	<b>1,163,000</b>
<b>8. Waste Water Treatment System</b>	<b>75,250</b>	<b>1</b>	<b>75,250</b>	<b>75,250</b>
<b>9. Bridge Crane(s)</b>		<b>2</b>	<b>541,050</b>	<b>541,050</b>
Gas Turbine Crane	343,250	1	343,250	343,250
Steam Turbine Crane	197,800	1	197,800	197,800
<b>10. Station/Instrument Air Compressors</b>	<b>52,450</b>	<b>2</b>	<b>104,900</b>	<b>104,900</b>
<b>11. Recip Engine Genset(s)</b>		<b>1</b>	<b>233,500</b>	<b>233,500</b>
Emergency Generator				
Black Start Generator	233,500	1	233,500	233,500
<b>12. General Plant Instrumentation</b>	<b>293,150</b>	<b>1</b>	<b>293,150</b>	<b>293,150</b>
<b>13. Medium Voltage Equipment</b>	<b>513,600</b>	<b>1</b>	<b>513,600</b>	<b>513,600</b>
Transformers	119,100			
Circuit Breakers	25,290			
Switchgear	199,500			
Motor Control Centers	145,250			
Miscellaneous	24,460			
<b>14. Low Voltage Equipment</b>	<b>1,786,000</b>	<b>1</b>	<b>1,786,000</b>	<b>1,786,000</b>
Transformers	665,700			
Circuit Breakers	664,000			
Switchgear				
Motor Control Centers	371,400			
Miscellaneous	85,050			
<b>15. Miscellaneous Equipment</b>	<b>701,971</b>		<b>701,971</b>	<b>701,971</b>
<b>16. User-defined</b>			<b>0</b>	<b>0</b>



	Material	Units	Labor Hours	Labor Rate	Unit Cost	Quantity	Ref. Cost	Est. Cost
<b>III Civil (USD)</b>	<b>12,423,930</b>		<b>255,133</b>	<b>39.01</b>			<b>22,376,919</b>	<b>28,470,371</b>
<b>1. Site Work</b>	<b>2,609,000</b>		<b>40,110</b>	<b>39.00</b>			<b>4,173,290</b>	<b>13,559,306</b>
Site Clearing	included		included					
Demolition	included		included					
Culverts & Drainage	included		included					
Erosion Control	included		included					
Fencing, Controlled Access Gates	included		included					
Finish Grading	included		included					
Finish Landscaping	included		included					
Material (Dirt, Sand, Stone)	included		included					
Waste Material Removal	included		included					
Obstacles R&R	included		included					
Soil Improvements	included		included					10,000,000
<b>2. Excavation &amp; Backfill</b>	<b>1,380,690</b>	<b>CY</b>	<b>27,826</b>	<b>39.00</b>	<b>54.02</b>	<b>45,649</b>	<b>2,465,902</b>	<b>2,039,956</b>
Gas Turbine (10)	33.40	CY	0.68	39.00	60.02	4,630	277,890	229,518
Steam Turbine (5)	33.51	CY	0.69	39.00	60.28	890	53,649	44,296
Heat Recovery Boiler (10)	28.49	CY	0.57	39.00	50.74	22,840	1,158,970	959,513
Water Cooled Condenser (5)	31.08	CY	0.62	39.00	55.35	1,600	88,564	73,318
Cooling Tower	32.43	CY	0.67	39.00	58.61	2,100	123,090	101,506
Air Cooled Condenser								
Underground Piping	28.04	CY	0.56	39.00	49.81	4,210	209,700	173,727
Switchyard	48.34	CY	1.00	39.00	87.33	89	7,769	6,407
Other & Miscellaneous	32.86	CY	0.67	39.00	58.80	9,290	546,270	451,670
<b>3. Concrete</b>	<b>8,003,090</b>	<b>CY</b>	<b>185,918</b>	<b>39.00</b>	<b>1,292.44</b>	<b>11,802</b>	<b>15,253,892</b>	<b>12,407,952</b>
Gas Turbine (10)	786.62	CY	14.69	39.00	1,359.49	2,990	4,064,880	3,392,574
Steam Turbine (5)	807.40	CY	17.47	39.00	1,488.62	608	905,080	742,514
Laydown pads:	844.69	CY	22.78	39.00	1,733.26	14	23,659	18,898
Heat Recovery Boiler (10)	576.36	CY	13.25	39.00	1,092.95	3,130	3,420,940	2,786,291
Water Cooled Condenser (5)	690.97	CY	20.15	39.00	1,476.92	393	580,430	459,195
Cooling Tower	719.62	CY	19.59	39.00	1,483.68	734	1,089,020	868,898
Air Cooled Condenser								
Underground Piping:								
Makeup Water Treatment System	554.04	CY	14.72	39.00	1,128.12	73	82,770	66,238
Auxiliary Boiler (0)								
Electrical Power Equipment	644.12	CY	18.25	39.00	1,355.98	1,700	2,305,170	1,830,178
Inlet Chilling System (0)								
Fuel Gas Compressor (2)	951.29	CY	24.69	39.00	1,914.13	75	142,660	114,494
Pumps (8)	840.58	CY	22.18	39.00	1,705.55	82	139,190	111,483
Auxiliary Heat Exchangers								
Feedwater Heater(s) (0)								
Station/Instrument Air Compressors (2)	1,121.01	CY	27.73	39.00	2,202.52	12	26,210	21,159
Bridge Crane(s)								0
Recip Engine Genset(s) (1)	987.96	CY	25.94	39.00	1,999.65	20	39,853	31,939
Tanks:	519.48	CY	15.09	39.00	1,108.09	593	657,100	520,098
Switchyard	567.19	CY	15.70	39.00	1,179.46	69	81,890	65,205
Miscellaneous	678.85	CY	15.77	39.00	1,293.92	1,310	1,695,040	1,378,787
<b>4. Roads, Parking, Walkways</b>	<b>431,150</b>		<b>1,279</b>	<b>41.19</b>	<b>6.29</b>	<b>76,921</b>	<b>483,835</b>	<b>463,156</b>
Pavement, Curbing, Striping	4.20	ft^2	0.01	39.00	4.61	76,900	354,770	342,340
Lighting	5,145.24		22.24	45.00	6,145.95	21	129,065	120,817
<b>5. User-defined</b>							<b>0</b>	<b>0</b>

\* NOTE: Individual items listed in III.2-4 are per unit quantity.

	Material	Units	Labor Hours	Labor Rate	Unit Cost	Quantity	Ref. Cost	Est. Cost
<b>IV Mechanical (USD)</b>	<b>12,340,730</b>		<b>435,344</b>	<b>44.00</b>			<b>31,495,866</b>	<b>23,265,088</b>
<b>1. On-Site Transportation &amp; Rigging</b>	<b>3,630,000</b>						<b>3,630,000</b>	<b>2,917,613</b>
<b>2. Equipment Erection &amp; Assembly</b>	<b>2,058,380</b>		<b>240,790</b>	<b>44.00</b>			<b>12,653,140</b>	<b>8,494,697</b>
Gas Turbine Package	32,880		3,910	44.00	204,920	10	2,049,200	1,373,943
Steam Turbine Package	42,000		4,990	44.00	261,560	5	1,307,800	876,914
HRSRG	76,850		9,130	44.00	478,570	10	4,785,700	3,208,949
Condenser	12,780		1,520	44.00	79,660	5	398,300	267,048
Cooling Tower	elsewhere		elsewhere					
Makeup Water Treatment System	50,750		2,540	44.00	162,510	1	162,510	118,644
Auxiliary Boiler								
Electrical Power Equipment	343,500		40,830	44.00			2,140,020	1,434,886
Inlet Chilling System								
Fuel Gas Compressor	5,260		625	44.00	32,760	2	65,520	43,933
Pumps	46,250		5,500	44.00			288,250	193,265
Tanks + Auxiliary Heat Exchangers	41,410		4,920	44.00			257,890	172,922
Feedwater Heater(s)								
Station/Instrument Air Compressors	2,040		242	44.00			12,688	8,509
Bridge Crane(s)	3,830		456	44.00			23,894	16,019
Recip Engine Genset(s)	1,780		212	44.00			11,108	7,447
Miscellaneous	187,100		21,890	44.00			1,150,260	772,220
<b>3. Piping</b>	<b>5,926,950</b>		<b>186,664</b>	<b>44.00</b>	<b>193.50</b>	<b>73,076</b>	<b>14,140,166</b>	<b>10,916,478</b>
High Pressure Steam	257.11	ft	6.42	44.00	539.39	4,430	2,389,480	1,898,667
Cold Reheat Steam								
Hot Reheat Steam								
Intermediate Pressure Steam	75.01	ft	3.44	44.00	226.19	4,520	1,022,370	754,167
Low Pressure Steam								
Other Steam								
Circulating Water	247.97	ft	1.99	44.00	335.73	1,800	604,310	542,311
Auxiliary Cooling Water	29.93	ft	1.50	44.00	95.81	22,810	2,185,400	1,595,629
Feedwater	70.15	ft	2.76	44.00	191.42	5,820	1,114,060	837,049
Other Water	28.00	ft	1.44	44.00	91.49	8,940	817,900	595,117
GT Inlet Chilling/Heating System								
Raw Water	44.38	ft	1.85	44.00	125.58	699	87,780	65,502
Service Water	58.38	ft	2.17	44.00	154.07	1,200	184,890	139,815
Waste Water								
Steam/Water Sampling								
Sanitary Water								
Vents								
Fuel Gas	178.47	ft	4.42	44.00	372.87	2,750	1,025,400	815,569
Fuel Oil	93.05	ft	3.35	44.00	240.41	2,750	661,140	502,083
Lube Oil	313.33	ft	9.84	44.00	746.24	1,800	1,343,240	1,037,388
Compressed Air								
GT Air Bleed								
Service Air	17.81	ft	1.32	44.00	75.70	897	67,900	47,521
Vacuum Air	134.09	ft	3.93	44.00	307.09	440	135,120	105,243
Trim								
Chemical Feed								
Nitrogen								
Oxygen								
Carbon Dioxide								
Ammonia	35.49	ft	1.91	44.00	119.69	3,470	415,310	300,637
Caustic								
Acid								
Boiler & Equipment Drain	70.64	ft	0.53	44.00	93.80	1,330	124,750	112,661
Boiler Blowdown	87.14	ft	1.97	44.00	173.82	1,330	231,180	185,933
Air Blowoff								
Steam Blowoff	388.00	ft	7.01	44.00	696.49	900	626,840	517,866
Chemical Cleaning								
Heat Tracing								
Fire Protection	37.66	ft	0.41	44.00	55.84	2,090	116,716	101,795
Miscellaneous	81.08	ft	2.55	44.00	193.41	5,100	986,380	761,525
<b>4. Steel</b>	<b>725,400</b>	<b>ton</b>	<b>7,890</b>	<b>44.00</b>	<b>5,309.70</b>	<b>202</b>	<b>1,072,560</b>	<b>936,300</b>
Racks, Supports, Ladders, Walkways, Platforms	3,591.09	ton	39.06	44.00	5,309.70	202	1,072,560	936,300
<b>5. User-defined</b>							<b>0</b>	<b>0</b>

\* NOTE: Individual items listed in IV.2-4 are per unit quantity.

	Material	Labor Hours	Labor Rate	Unit Cost	Quantity	Ref. Cost	Est. Cost
<b>V Electrical (USD)</b>	<b>4,965,510</b>	<b>167,992</b>	<b>45.00</b>			<b>12,525,136</b>	<b>9,557,983</b>
<b>1. Controls</b>	<b>610,000</b>	<b>55,379</b>	<b>45.00</b>			<b>3,102,041</b>	<b>2,123,915</b>
Gas Turbine Package	18,010	1,670	45.00	93,160.00	10	931,600	636,636
Steam Turbine Package	23,010	2,140	45.00	119,310.00	5	596,550	407,561
HRSg	24,560	2,280	45.00	127,160.00	10	1,271,600	868,895
Condenser	2,880	268	45.00	14,940.00	5	74,700	51,032
Cooling Tower	elsewhere	elsewhere					
Makeup Water Treatment System	6,820	634	45.00	35,350.00	1	35,350	24,152
Auxiliary Boiler							
Electrical Power Equipment							
Inlet Chilling System							
Fuel Gas Compressor	7,200	268	45.00	19,260.00	2	38,520	29,053
Pumps	25,340	2,360	45.00			131,540	89,857
Auxiliary Heat Exchangers							
Feedwater Heater(s)							
Station/Instrument Air Compressor	2,790	104	45.00			7,470	5,633
Bridge Crane(s)	3,060	114	45.00			8,190	6,176
Recip Engine Genset(s)	2,440	91	45.00			6,521	4,919
<b>2. Assembly &amp; Wiring</b>	<b>4,355,510</b>	<b>112,613</b>	<b>45.00</b>			<b>9,423,095</b>	<b>7,434,068</b>
Switchgear	5,450	353	45.00	21,335.00	1	21,335	15,100
Motor Control Centers	248	48	45.00	2,387.02	57	136,060	88,195
Feeders	5,580	202	45.00	14,676.75	200	2,935,350	2,221,255
Medium/Low Voltage Cable Bus	22,110	369	45.00	38,734.93	73	2,827,650	2,351,293
Cable Tray	401,100	7,910	45.00	757,050.00	1	757,050	617,340
General Plant Instrumentation	1,133	19	45.00	1,987.89	227	451,250	375,125
Generator to Step-up Transformer Bus	5,150	80	45.00	8,750.00	15	131,250	110,055
Transformers	11,648	541	45.00	36,011.91	21	756,250	555,427
Circuit Breakers	9,991	310	45.00	23,921.74	23	550,200	424,443
Miscellaneous	395,900	10,240	45.00	856,700.00	1	856,700	675,836
<b>3. User-defined</b>						<b>0</b>	<b>0</b>

\* NOTE: Individual items listed in V.1 - 2 are per unit quantity.

	Area	Cost/Unit Area	Ref. Cost	Est. Cost
<b>VI Buildings (USD)</b>			1,899,881	14,527,030
1. Turbine Hall				
2. Administration, Control Room, Machine Shop / Warehouse	13,300.0	134.87	1,793,771	1,441,743
3. Water Treatment System	576.0	136.74	78,762	63,305
4. Guard House	200.0	136.74	27,348	21,981
5. Shore Protection				8,000,000
6. Barge Unloading Facility				5,000,000
7. Bridge to Mainland				0

	Material	Labor Hours	Labor Rate	Unit Cost	Quantity	Ref. Cost	Est. Cost
<b>VII Engineering &amp; Startup (USD)</b>	519,200	17,220	105.00			15,833,300	15,833,300
1. Engineering						13,506,000	13,506,000
2. Start-Up	519,200	17,220	105.00	2,327,300		2,327,300	2,327,300
3. User-defined						0	0

	Ref. Cost	Est. Cost
<b>VIII Soft &amp; Miscellaneous Costs (USD)</b>	<b>118,065,506</b>	<b>108,218,648</b>
<b>1. Contractor's Soft Costs</b>	<b>84,068,171</b>	<b>72,804,716</b>
Contingency:	37,105,731	26,363,826
Profit:	26,404,841	23,993,051
Permits, Licenses, Fees, Miscellaneous	0	0
Bonds and Insurance	5,873,600	6,413,668
Spare Parts & Materials	0	0
Contractor's Fee	14,684,000	16,034,171
<b>2. Owner's Soft Costs</b>	<b>33,997,335</b>	<b>35,413,932</b>
Permits, Licenses, Fees, Miscellaneous	7,554,963	7,869,763
Land Cost	0	0
Utility Connection Cost	0	0
Legal & Financial Costs	7,554,963	7,869,763
Escalation and Interest During Construction	15,109,927	15,739,525
Spare Parts & Materials	0	0
Project Administration & Developer's Fee	3,777,482	3,934,881
<b>3. Total of all user-defined costs displayed on each account</b>	<b>0</b>	<b>0</b>

	Multiplier
<b>Labor Rate</b>	<b>0.6075</b>
<b>Specialized Equipment</b>	<b>1.1000</b>
1. Gas Turbine Package	1.1000
2. Steam Turbine Package	1.1000
3. Heat Recovery Boiler	1.1000
4. Water-cooled Condenser	1.1000
5. Air-cooled Condenser	1.1000
6. Inlet Chilling System	1.1000
7. Fuel Gas Compressor	1.1000
8. Continuous Emissions Monitoring System	1.1000
9. Distributed Control System	1.1000
10. Transmission Voltage Equipment	1.1000
11. High (Generating) Voltage Equipment	1.1000
<b>Other Equipment</b>	<b>1.0000</b>
1. Pumps	1.0000
2. Tanks	1.0000
3. Cooling Tower	1.0000
4. Auxiliary Heat Exchangers	1.0000
5. Feedwater Heater	1.0000
6. Auxiliary Boiler	1.0000
7. Makeup Water Treatment System	1.0000
8. Waste Water Treatment System	1.0000
9. Bridge Crane(s)	1.0000
10. Station/Instrument Air Compressor	1.0000
11. Recip Engine Genset(s)	1.0000
12. General Plant Instrumentation	1.0000
13. Medium Voltage Equipment	1.0000
14. Low Voltage Equipment	1.0000
<b>Gasification Plant</b>	
1. Gasification	0.9373
2. Air Separation Unit	0.9373
3. Gas Cleanup System	0.9373
4. Gasification Plant Water Systems	0.9373
5. Gasification Plant General Facilities	0.9373
<b>Desalination Plant</b>	
1. Desalination	1.0111
<b>CO2 Capture Plant</b>	<b>0.9373</b>
<b>Commodity</b>	<b>1.0000</b>

<b>Contractor's Soft Costs</b>	<b>Percentage, %</b>	<b>+ Fixed Amount</b>
1. Contingency		
Labor	75.0	0
Specialized Equipment	3.0	0
Other Equipment	4.0	0
Commodities	6.0	0
2. Profit		
Labor	25.0	0
Specialized Equipment	7.0	0
Other Equipment	7.0	0
Commodities	7.0	0
3. Permits, Licenses, Fees & Miscellaneous	0.0	0
4. Bonds and Insurance	2.0	0
5. Spare Parts and Materials	0.0	0
6. Contractor's Fee	5.0	0
<b>Owner's Soft Costs</b>		
1. Permits, Licenses, Fees & Miscellaneous	2.0	0
2. Land Cost	0.0	0
3. Utility Connection Cost	0.0	0
4. Legal and Financial Costs	2.0	0
5. Interest During Construction	4.0	0
6. Spare Parts and Materials	0.0	0
7. Project Administration and Developer's Fee	1.0	0